

# Apoptosis-based Therapies: Mechanisms and Applications

- Perspective
- Bcl-2 family members, potential usage of BH3 domains as drug targets
- Bcl-2/xL inhibitors - Antisense, inhibitors of protein-protein interactions, SAR
- Caspases, apoptosome, inflammasome
- Caspase inhibitors and how they work
- TNFR, CD95/Fas, ApoL
- TRAIL and decoy receptors

# Cell Death is a Physiological Response of Cells To Changes in the Extracellular Environment

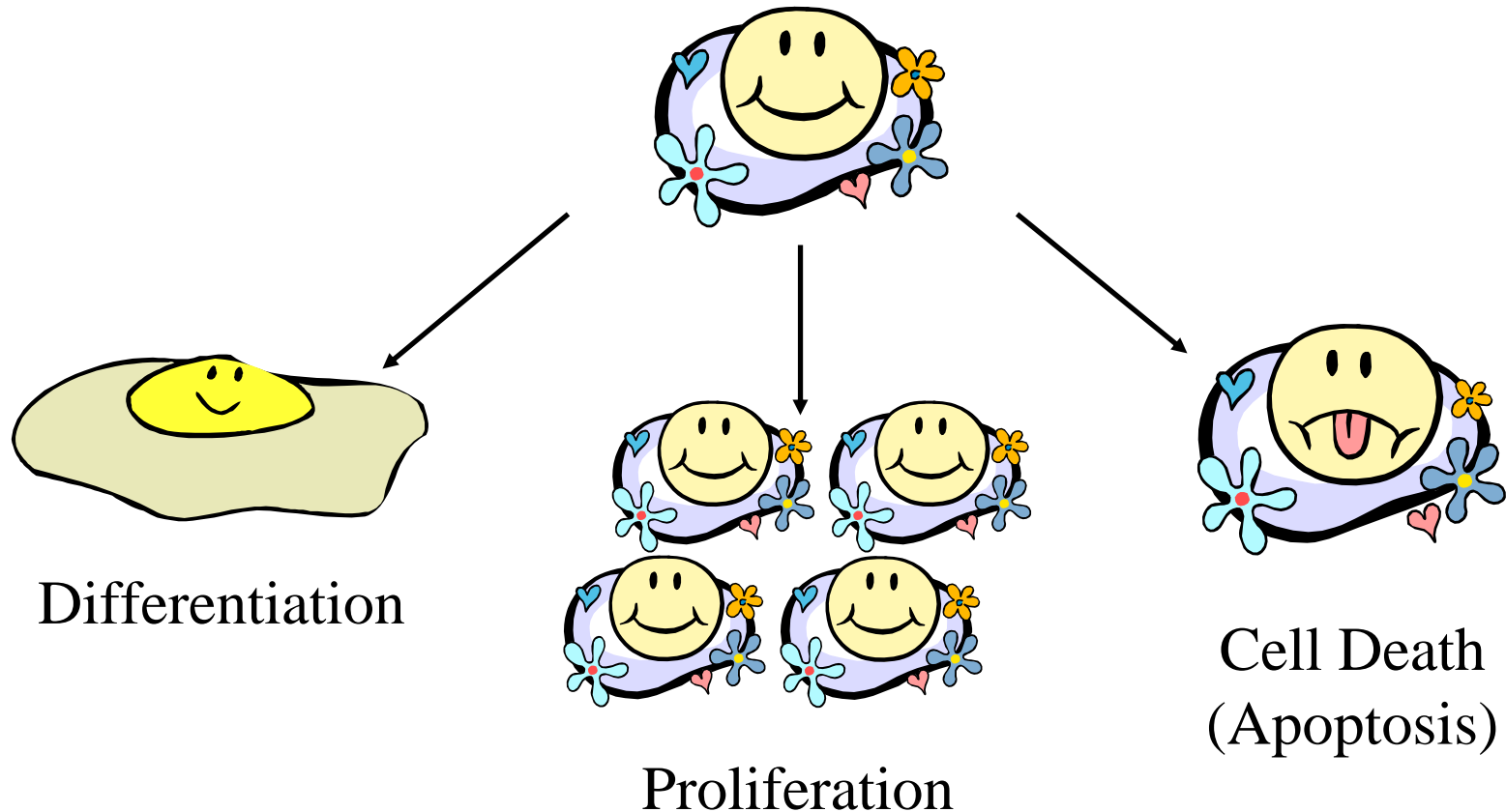

# Historical Observations of Apoptosis in Development

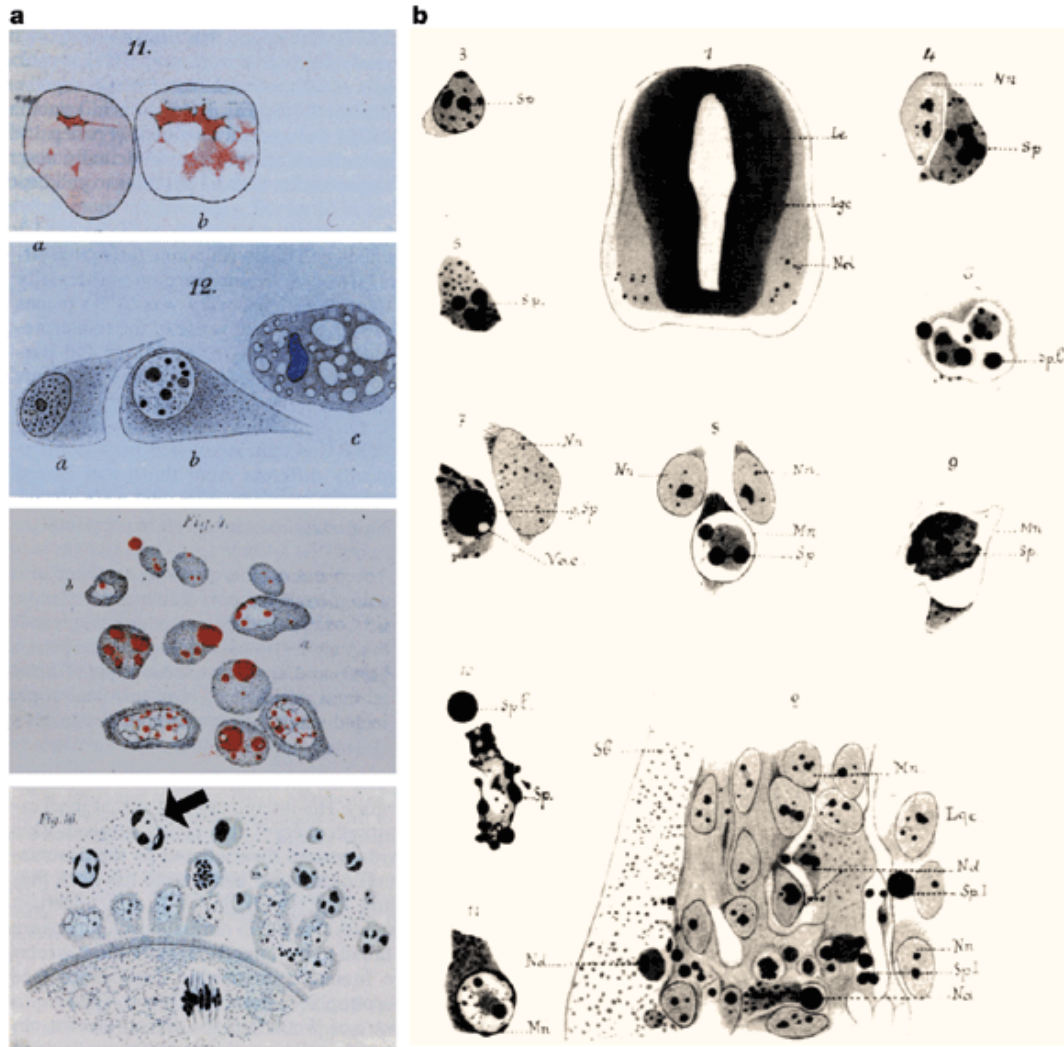

# Historical Timeline of Apoptosis Research

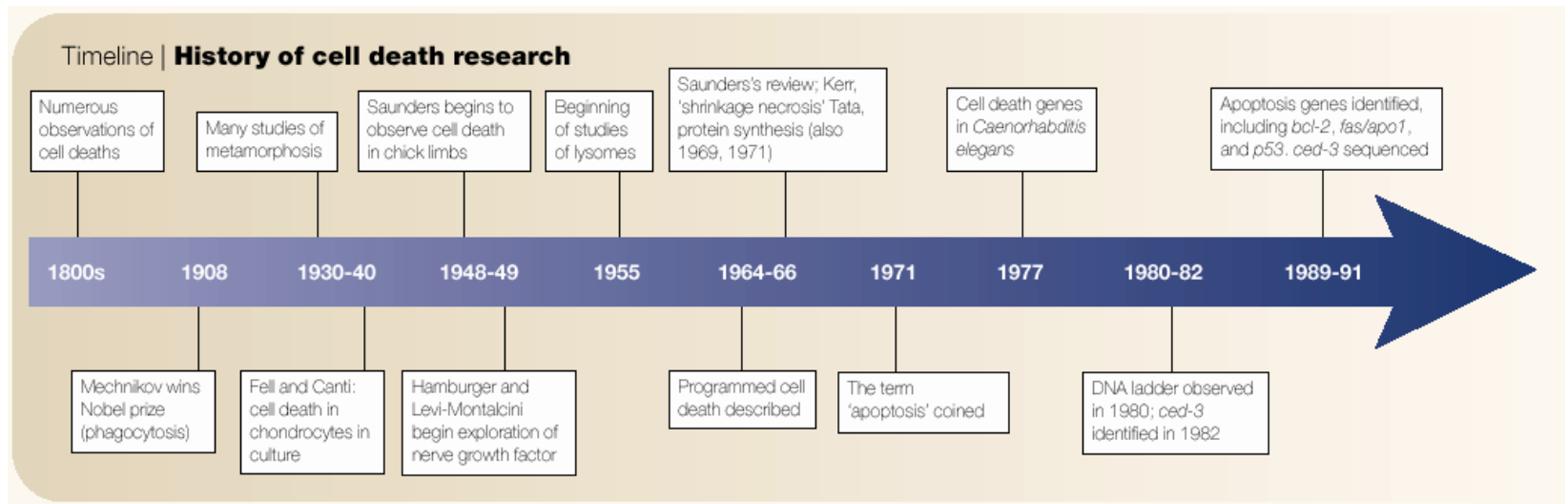

# Diseases Associated with Defective Apoptosis Regulation

## *I) Insufficient apoptosis*

- **Cancer (cell accumulation; resistance to chemotherapy, radiation and immunotherapy)**
- Autoimmunity (failure to eliminate autoreactive lymphocytes)
- Restenosis (accumulation of vascular smooth muscle cells)
- Persistent infections (failure to eradicate bacteria- or virus-infected cells)

# Diseases Associated with Defective Apoptosis Regulation

## *II) Excessive apoptosis*

- Ischemia — reperfusion injury (stroke, myocardial infarction)
- Heart failure (myocyte loss)
- Neurodegeneration (Alzheimer's, Parkinson's, Huntington's and amyotrophic lateral sclerosis=ALS)
- Inflammation
- Osteoarthritis (chondrocyte depletion)

# Diseases Associated with Defective Apoptosis Regulation

## *II) Excessive apoptosis (cont'd)*

- HIV (depletion of T-lymphocytes)
- Bacterial infection using apoptosis-inducing virulence proteins
- Allograft rejection and graft versus host disease
- Type I diabetes
- Trauma (spinal cord injury, brain injury)

# Oncology Targets

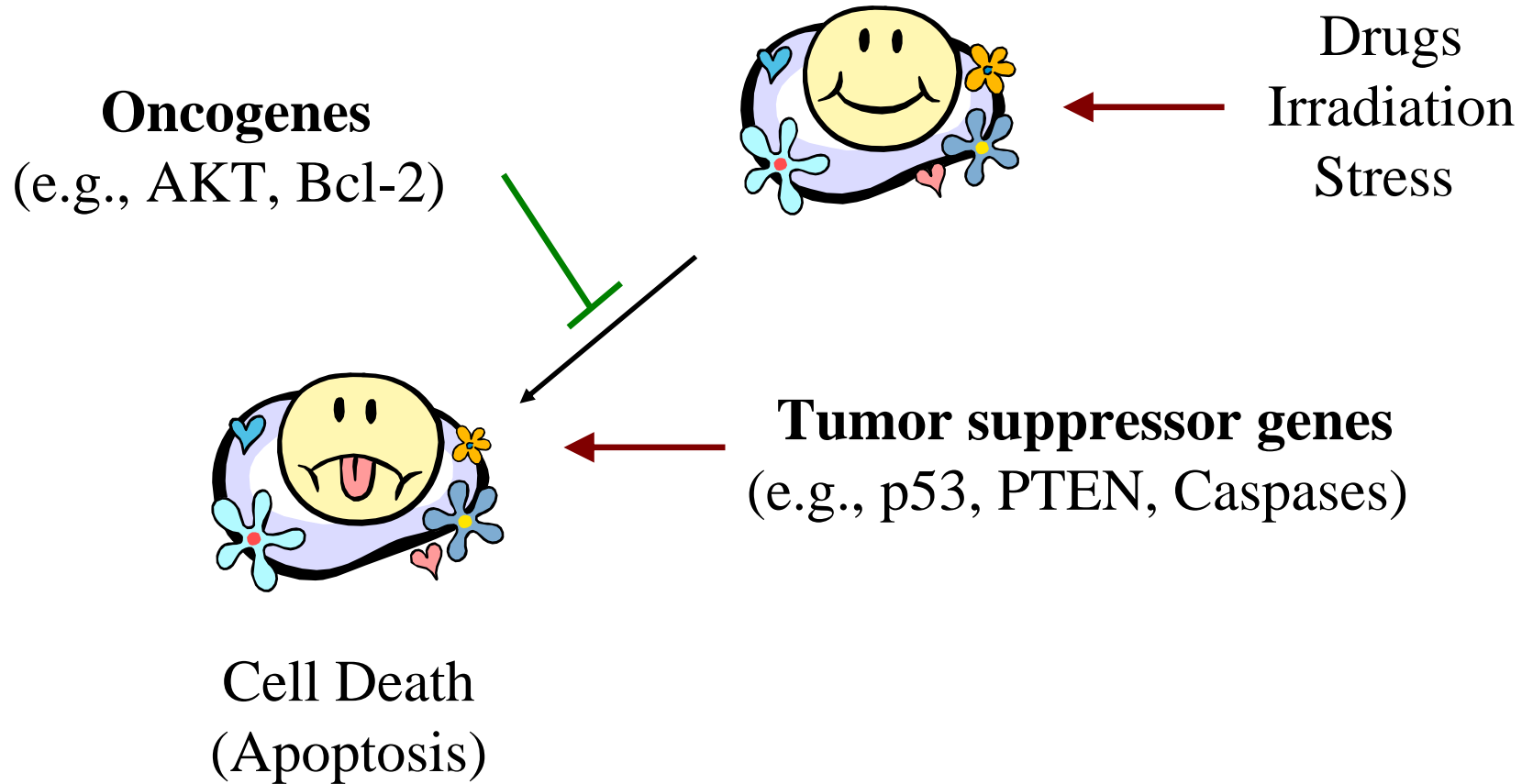

# The Core Cell Death Machinery

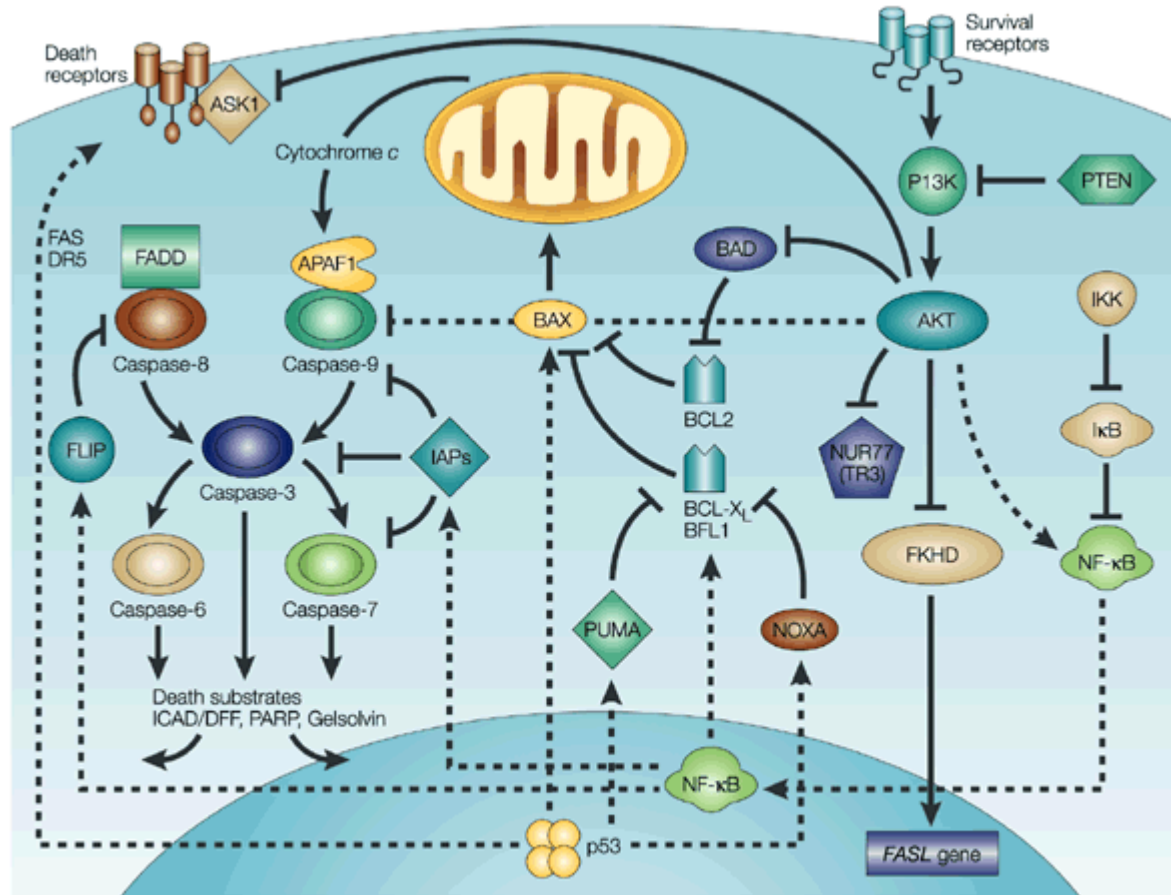

Nature Reviews | Drug Discovery

# Mitochondria Conduct Apoptotic Signaling

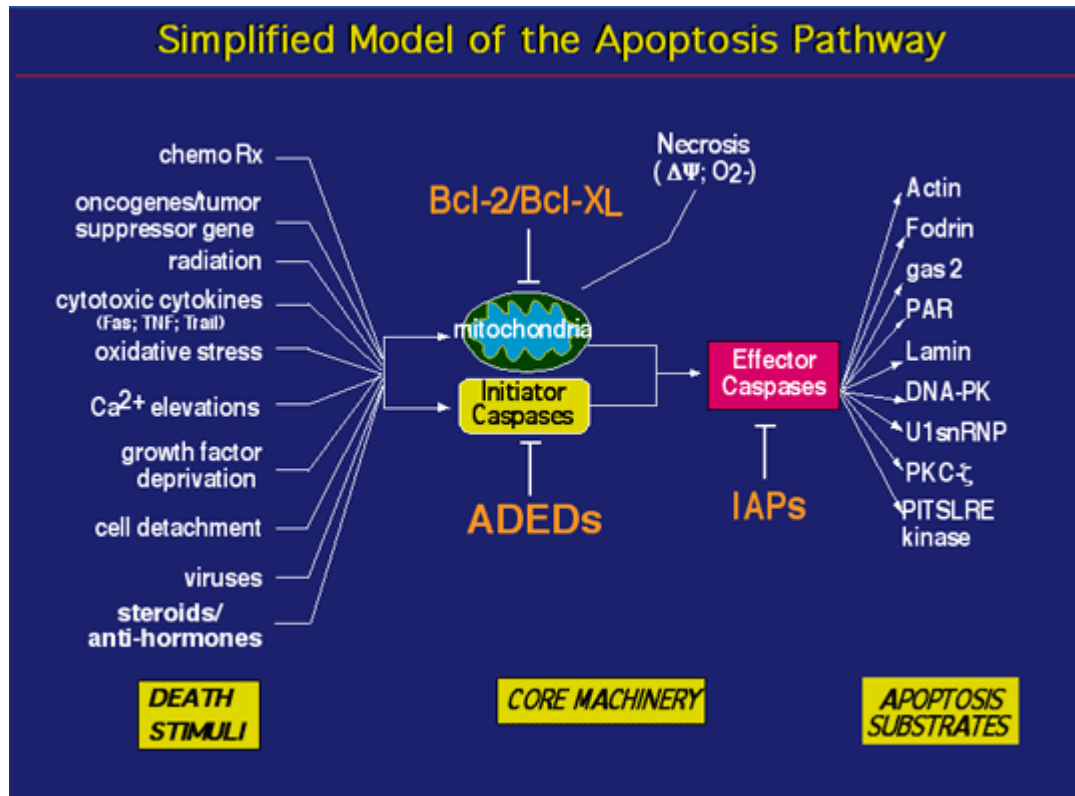

# Bcl-2 Proteins as Conserved Gatekeepers Of Mitochondrial Integrity

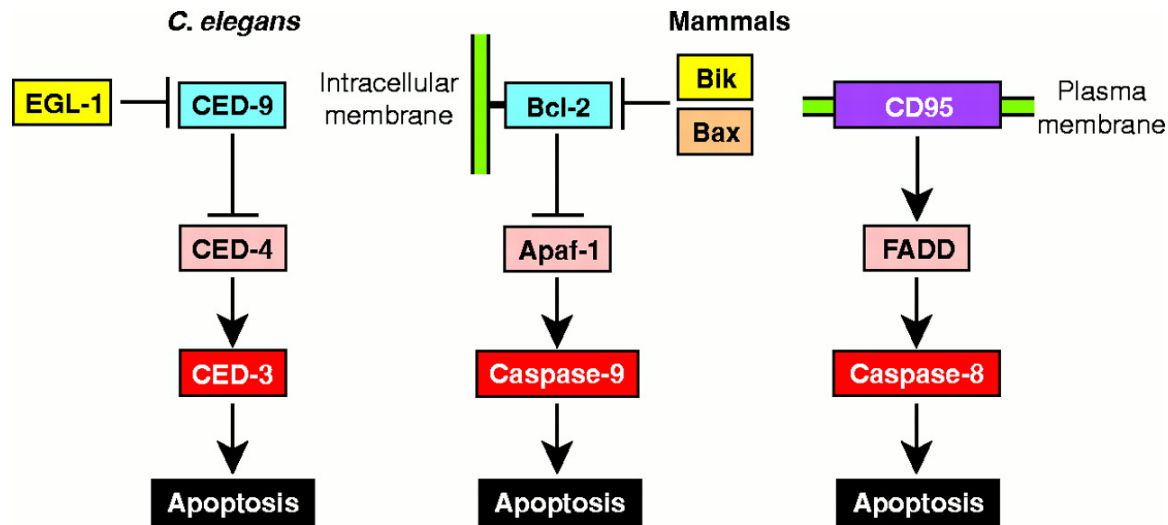

# Death Signals Inhibit the Anti-Apoptotic Bcl-2 Family Member CED-9 in Lower Eukaryotes

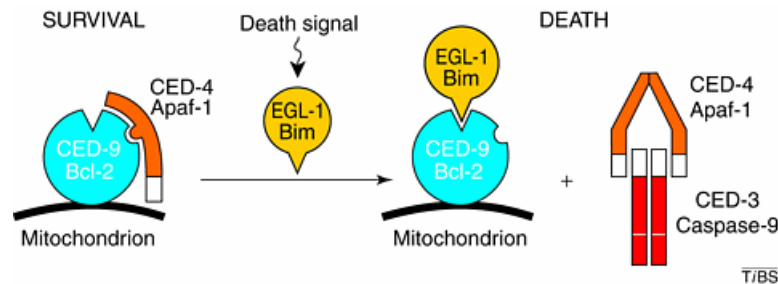

# Conservation of a Common Death Pathway Involving Bcl-2-Type Proteins

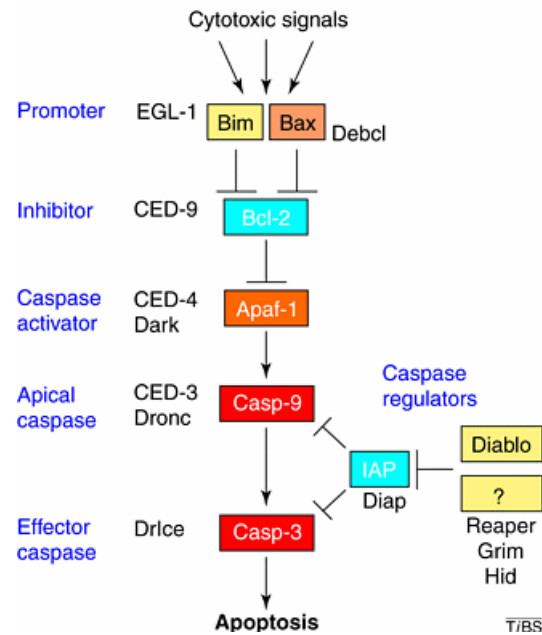

# Bcl-2-Type Proteins are Characterized by a BH3 Domain of Protein-Protein Interactions...

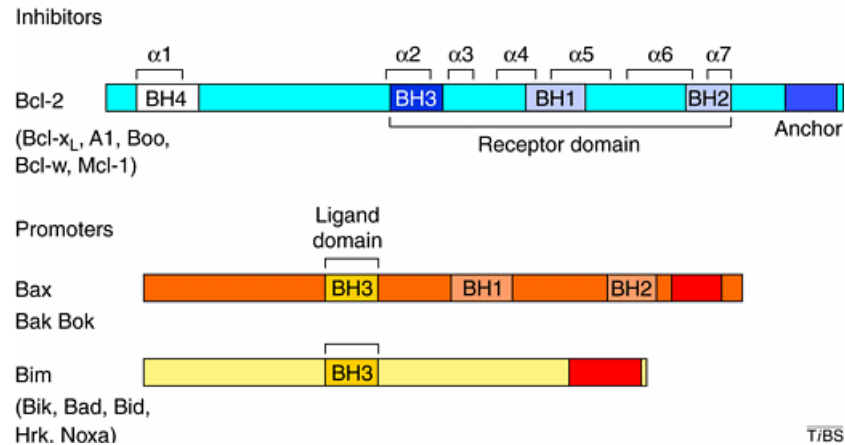

# ...but Comprise a Family of Structurally and Functionally Diverse Proteins

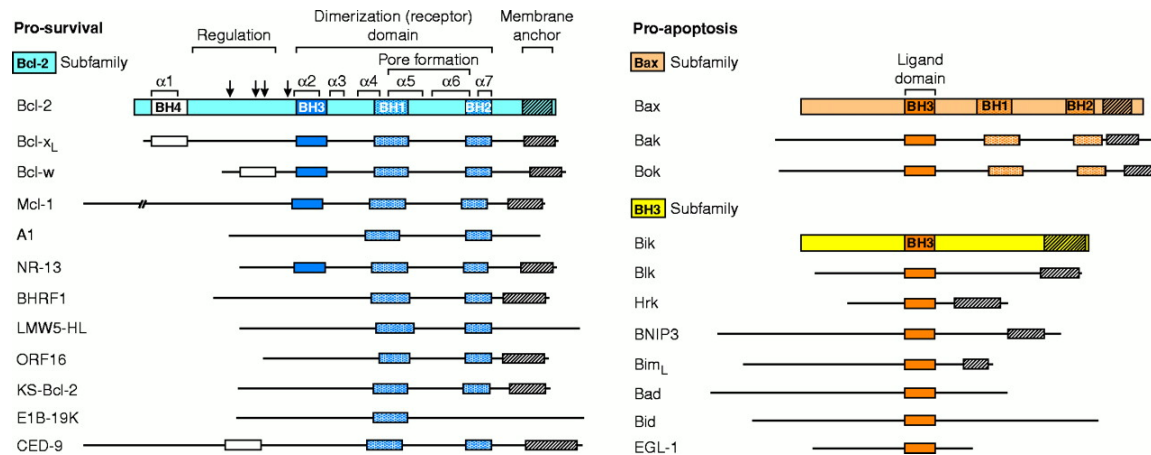

# Pro-Apoptotic Bcl-2 Family Members in Mammals Comprise Functionally Distinct Sentinels...

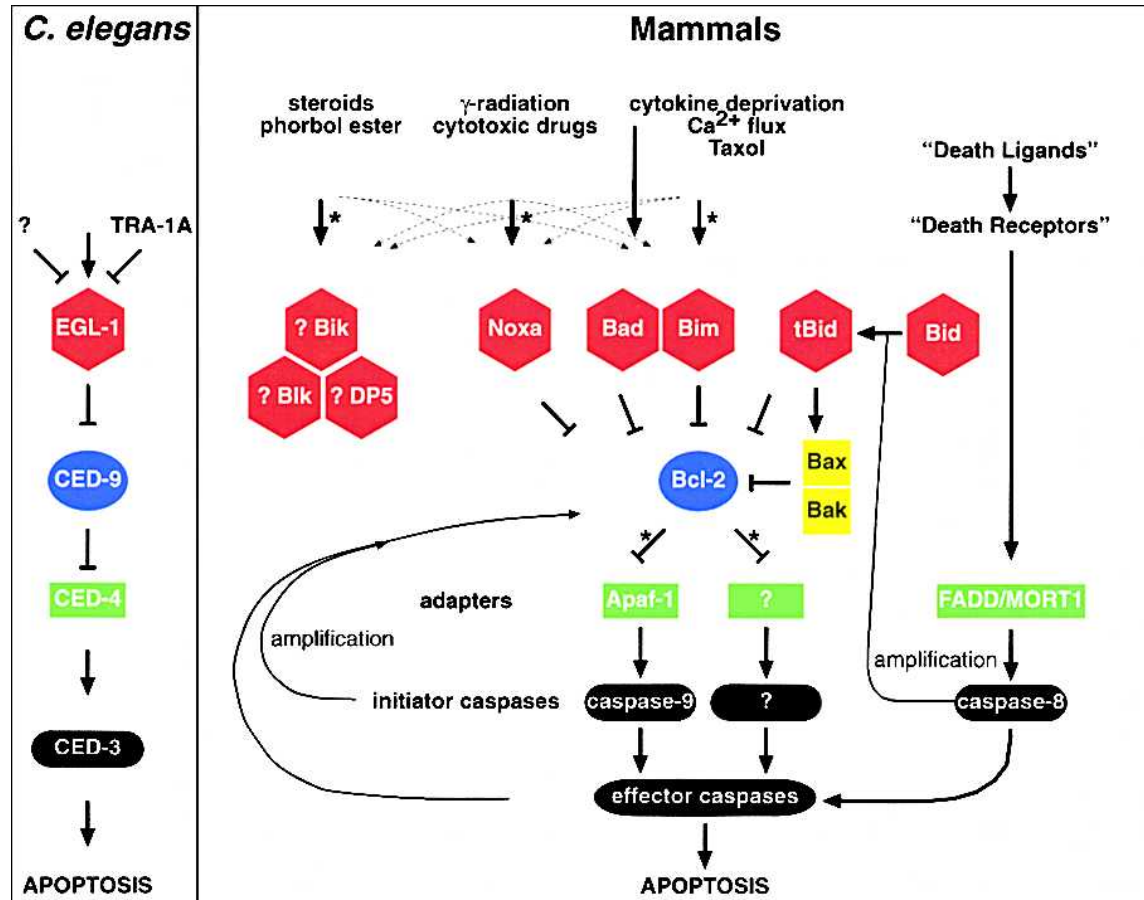

# ...That Sense Cellular Stress and are Activated by Multiple Mechanisms...

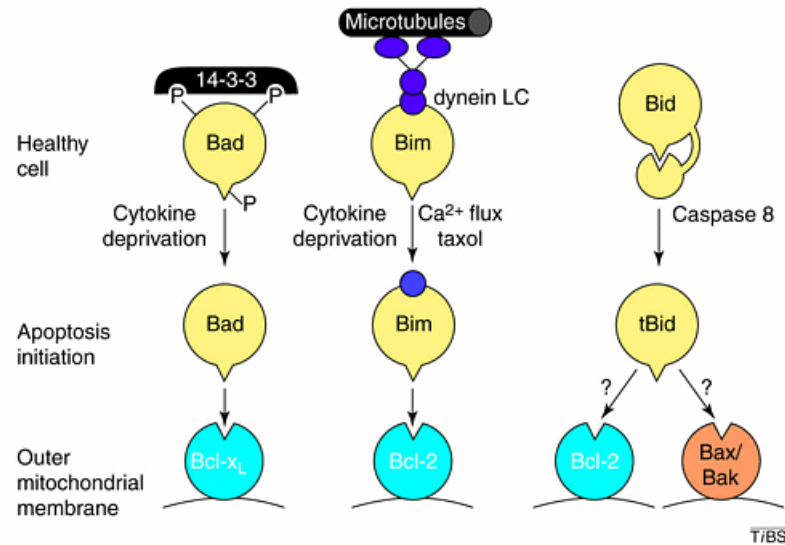

# ...Including Cleavage by Cellular Proteases

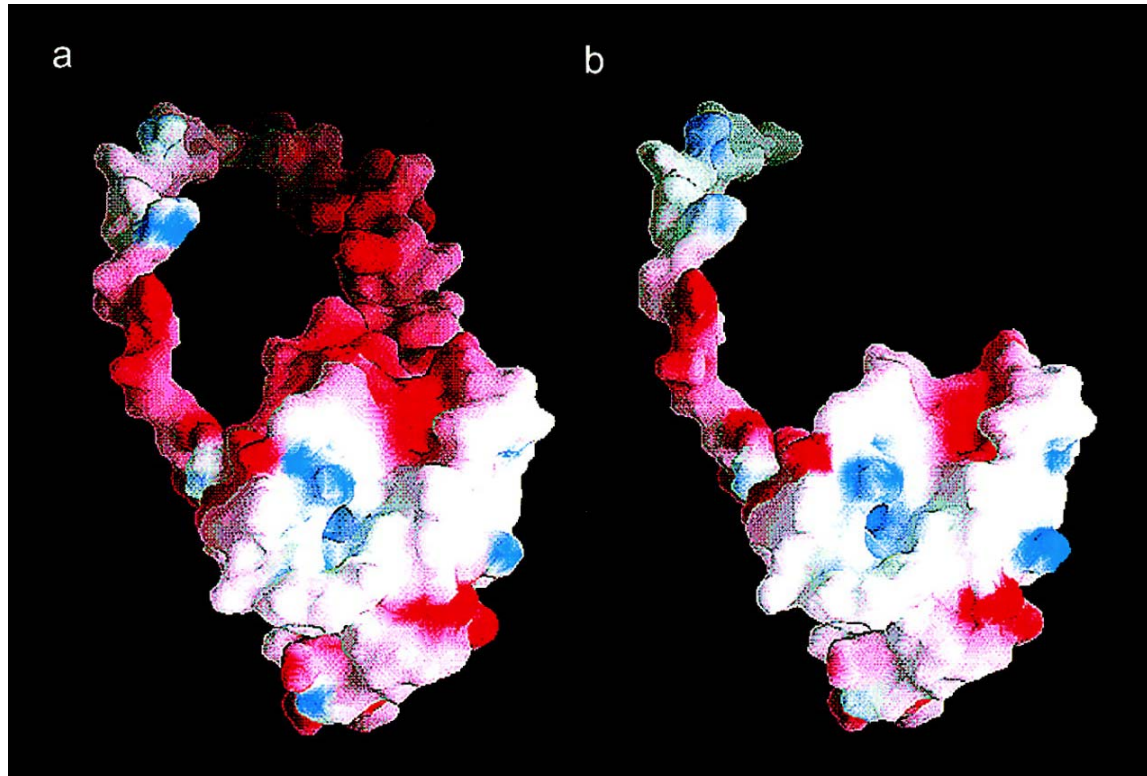

BID (inactive)  $\rightarrow$  tBID (active)

# Inhibition of Bcl-2/Bcl-x<sub>L</sub> Results in the Release of Apoptogenic Factors

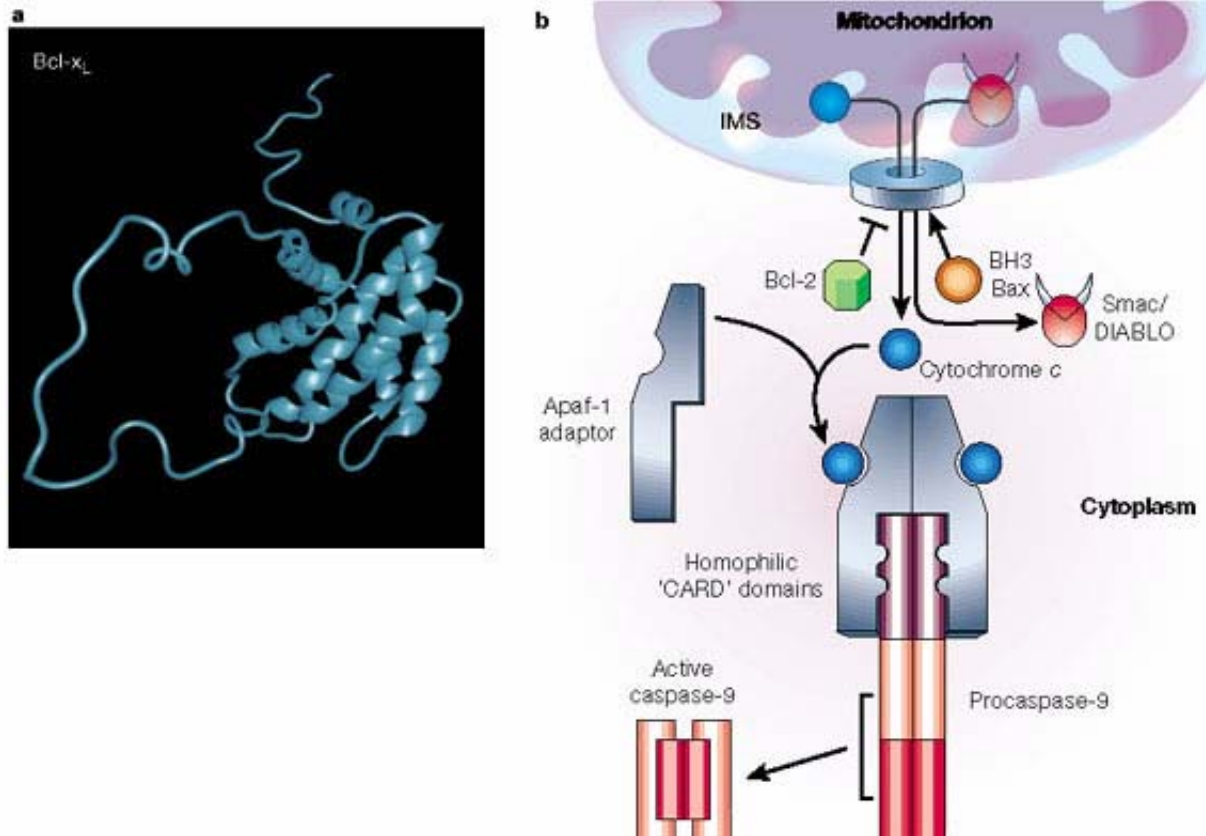

# Bcl-2/Bcl-x<sub>L</sub> as Drug Targets

- Antisense Oligonucleotides [e.g. Genta=G-3139 (5'-d(P-thio)TCT-CCC-AGC-GTG-CCC-CAT-3')
- Natural Compounds (Antimycin A<sub>3</sub> binds to the hydrophobic groove in Bcl-x<sub>L</sub> and inhibits protein-protein interactions)
- Small compounds (HA14.1 targeting Bcl-2)
- SAR by NMR = structure-activity relationships by nuclear magnetic resonance

# Identification of HA14-1 by Computer Screening

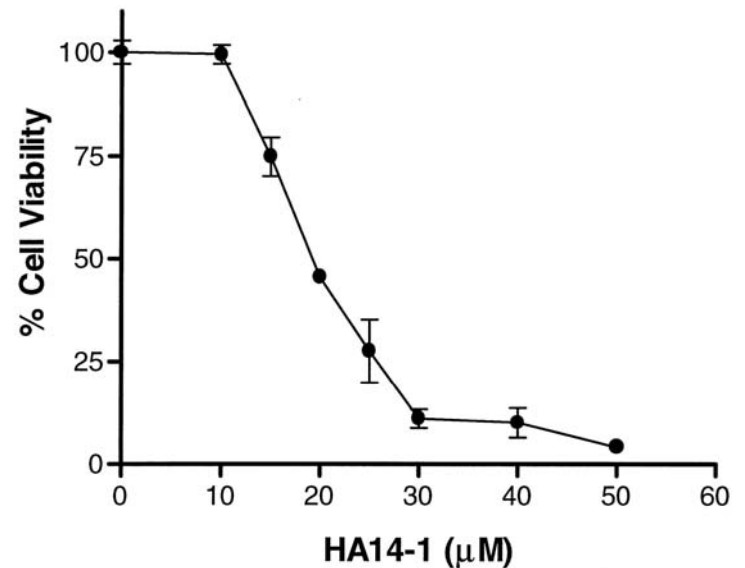
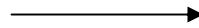
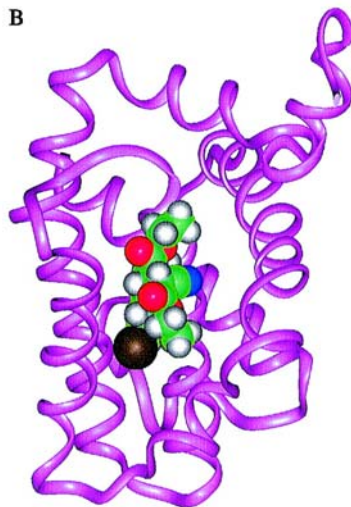
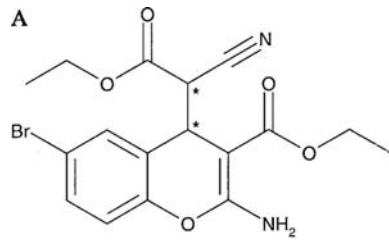

# SAR-by-NMR Method: Screening for Small Molecules and Improving their Affinities using Linkers and NMR

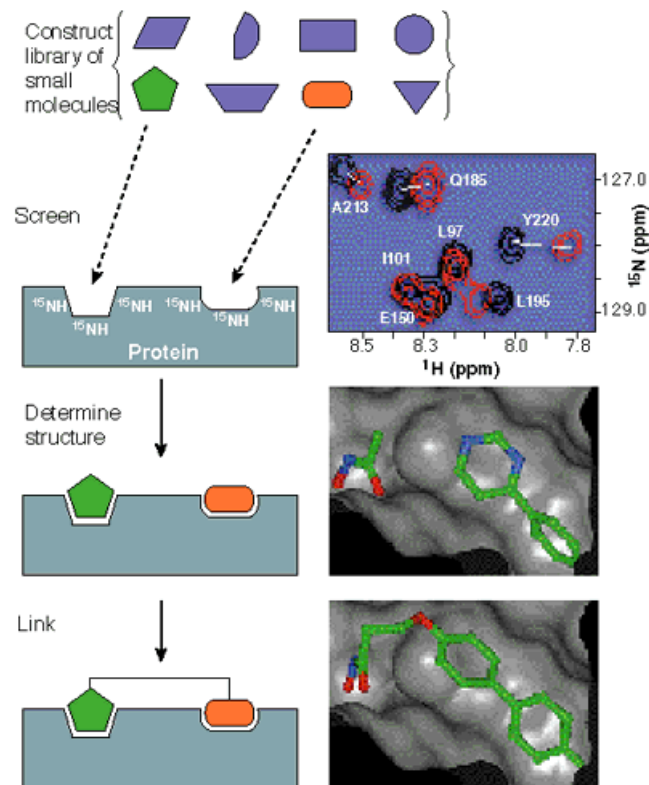

# Advantage over Conventional Library Methods: Fewer Compounds have to be Synthesized

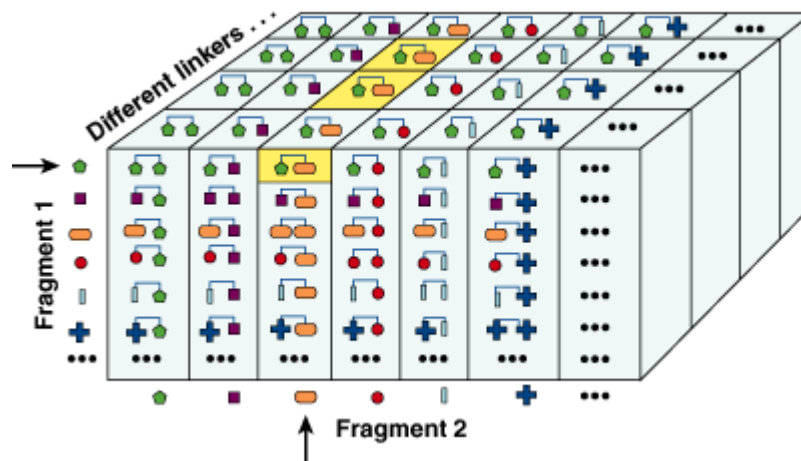

# Sequence-Specific Proteases (Caspases) Execute Apoptotic Disassembly of Cellular Proteins

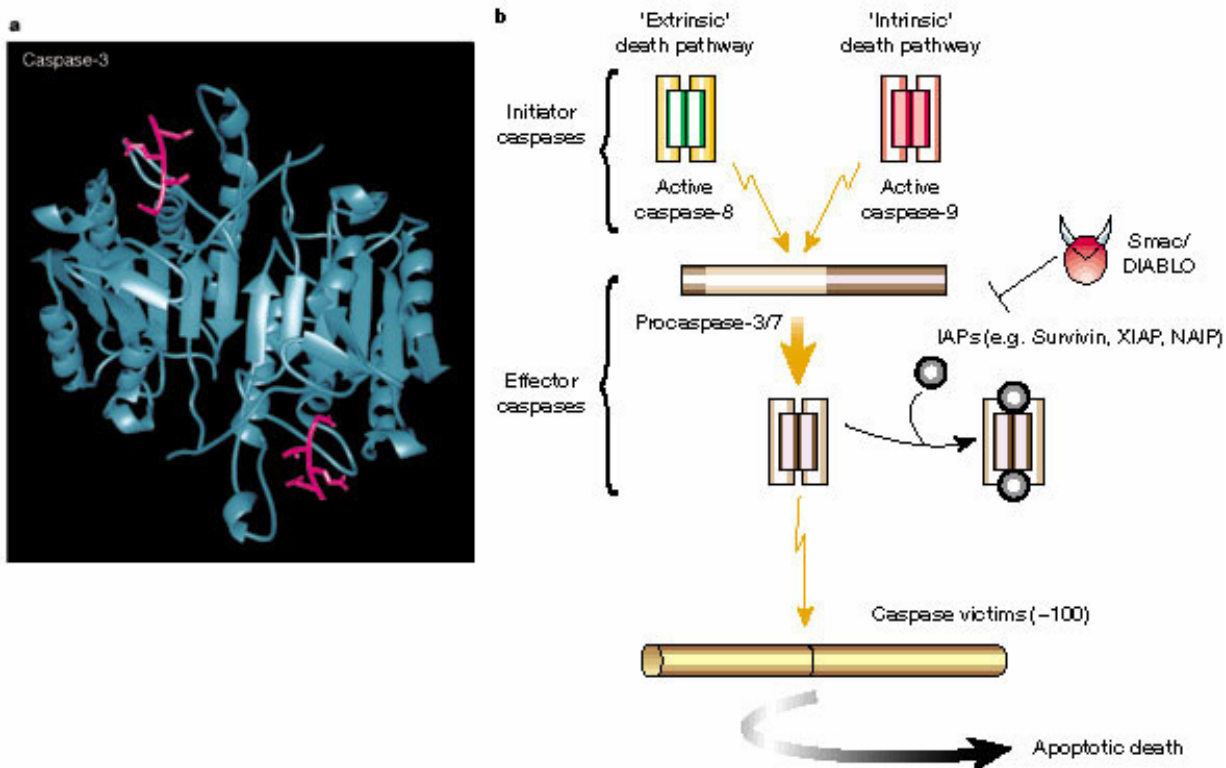

# Caspases Contain Similar Catalytic Subunits And Distinct N-terminal Regulatory Domains

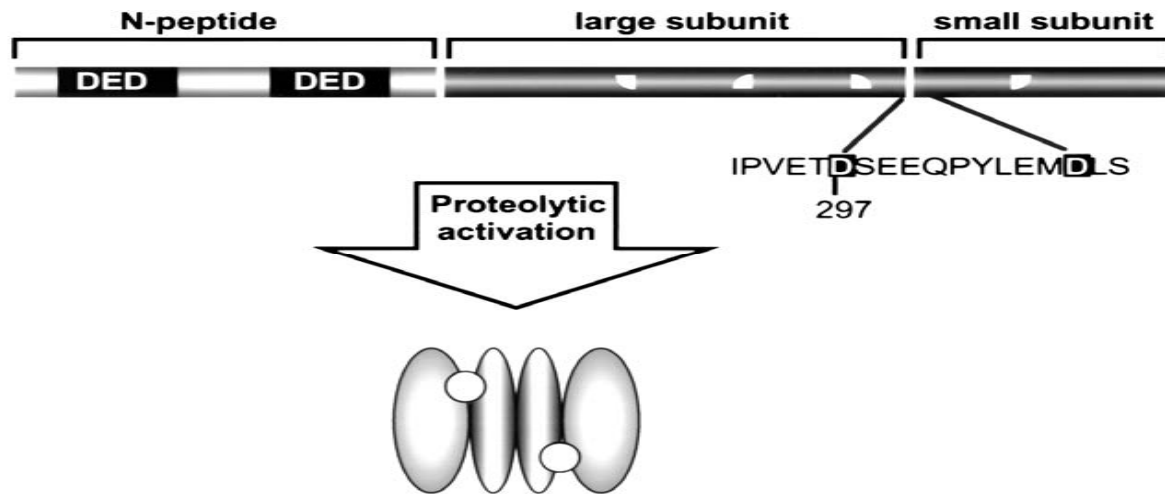

# Initiator Caspases (Caspase-8,9) are Activated According to the Forced-Proximity-Model...

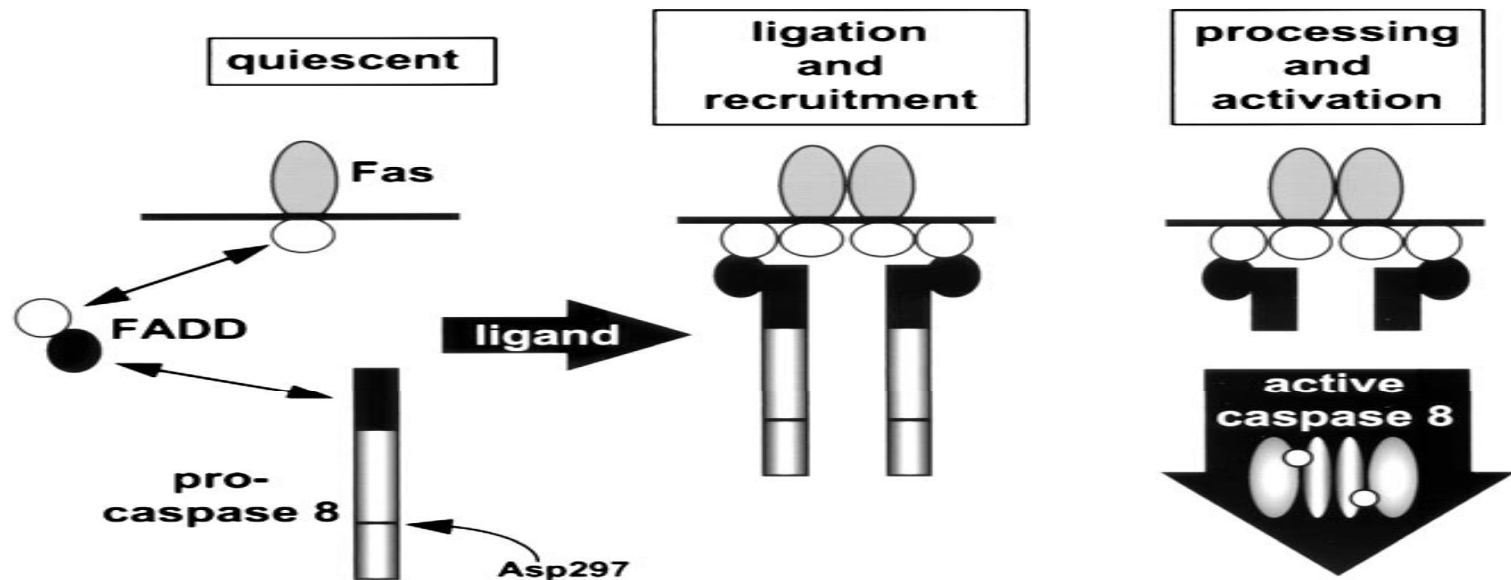

# ...Downstream of Death Signals (Caspase-8) Or Mitochondrial Damage (Caspase-9)

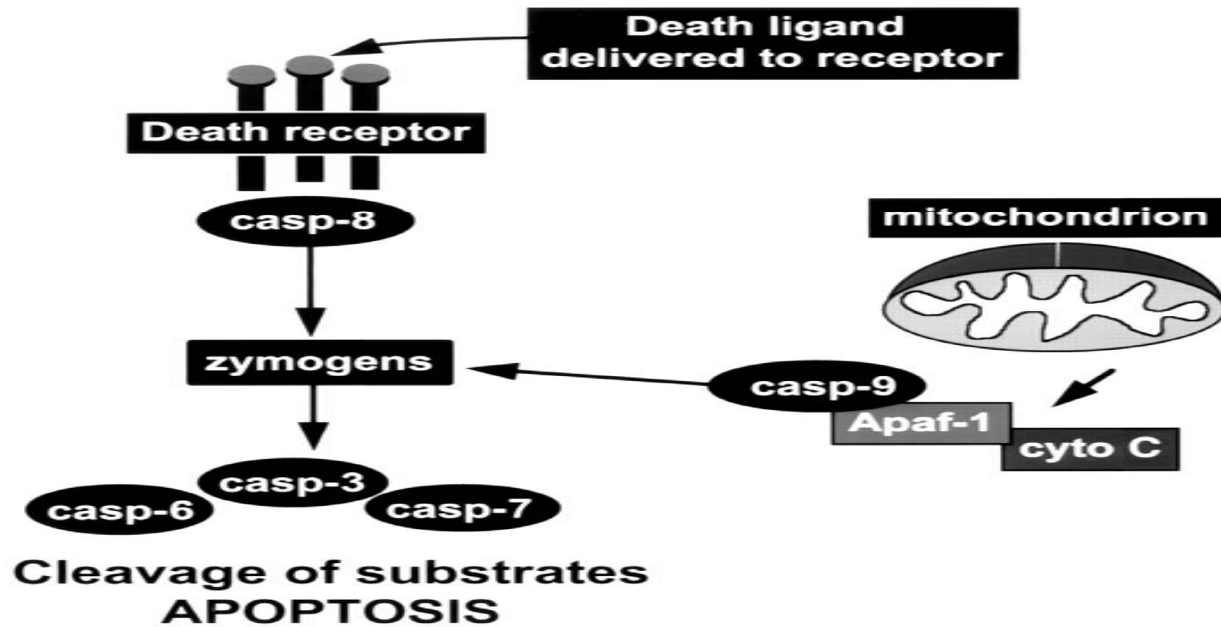

# Executioner Caspases (Caspase-3,6,7) Form Structural Heterodimers

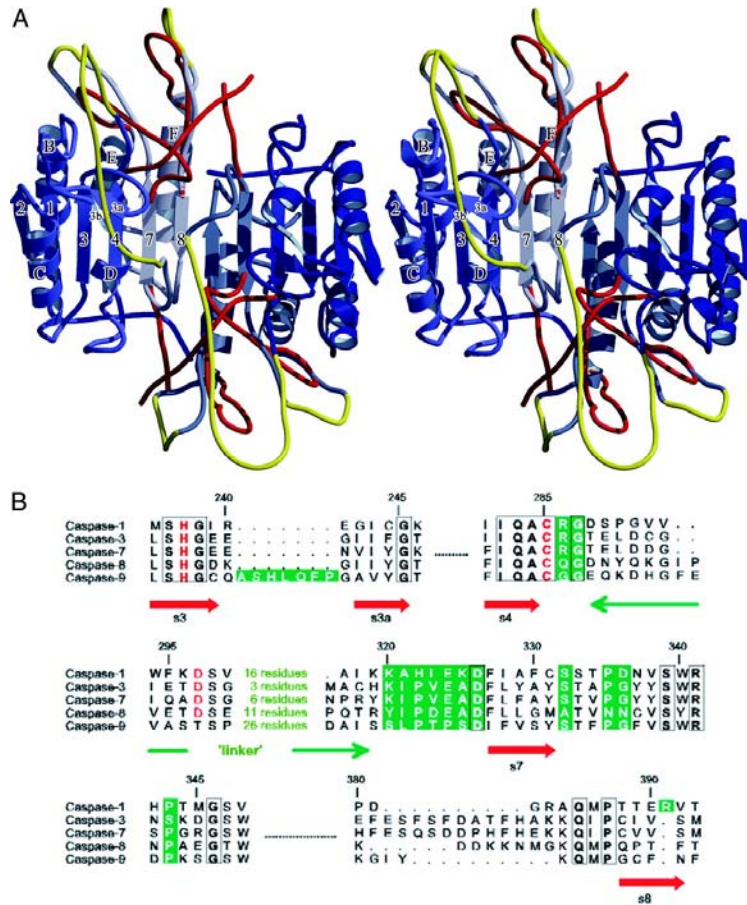

# Executioner Caspases Require Processing by Upstream Proteases for Dimer Formation (=Activation)

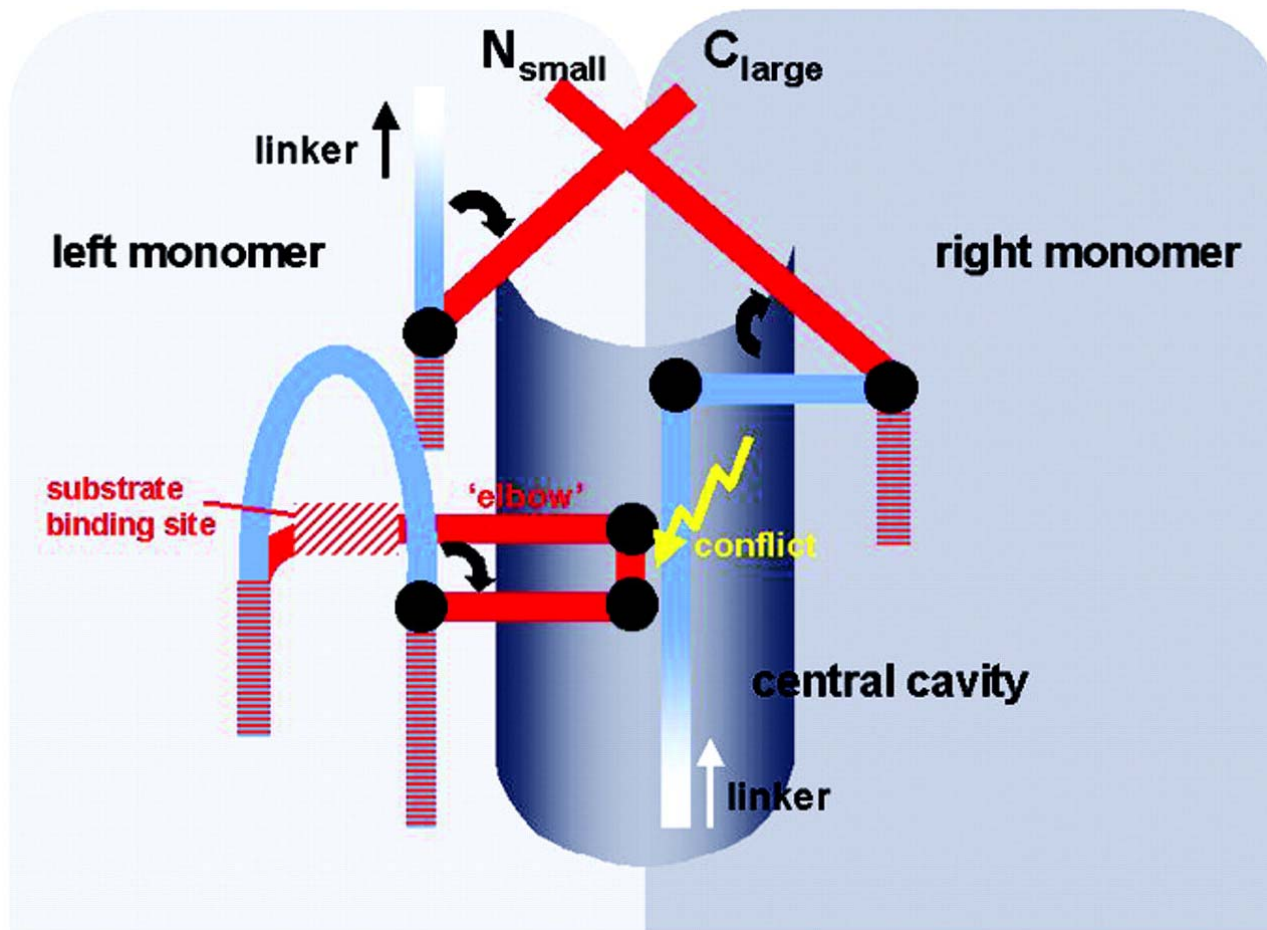

# Caspase-9 Differs from Other Caspases by Having Only a Single Active Site...

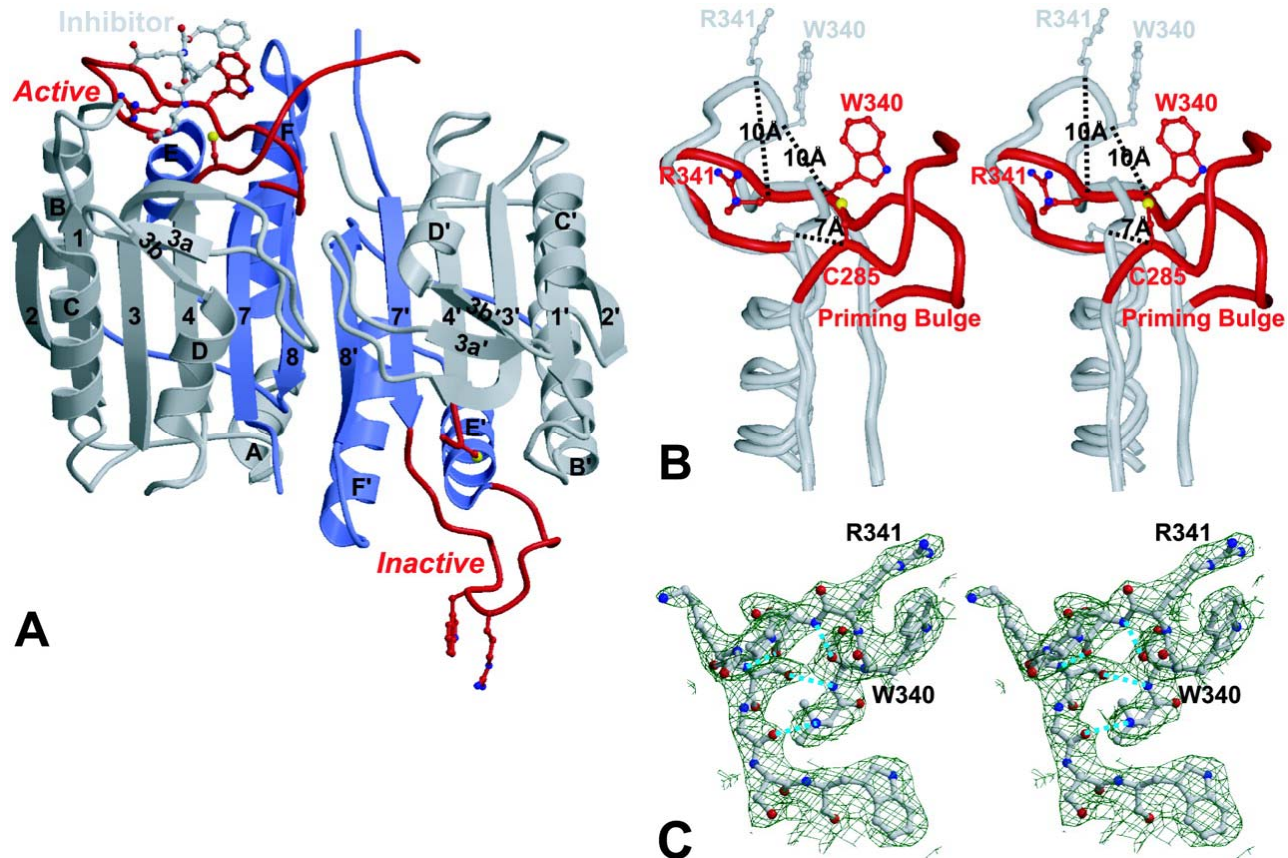

# ...that is Formed by the Induced Complex Formation of Caspase-9 Molecules

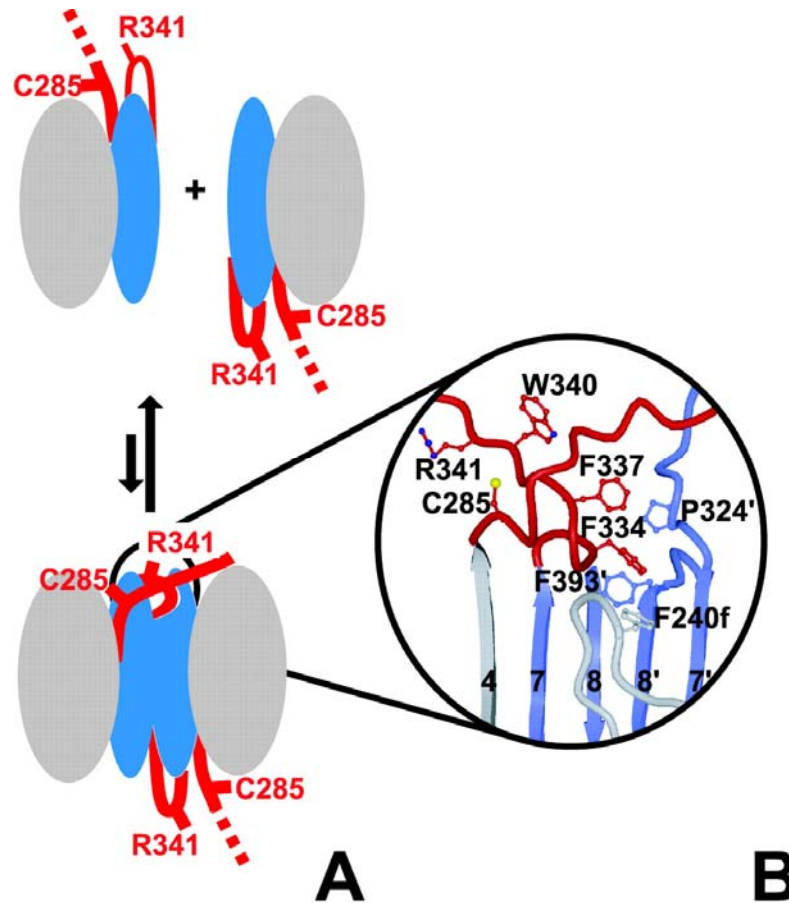

# Apaf-1 Mediates the ATP/dATP- and Cytochrome *c*-Dependent Multimerization of Caspase-9

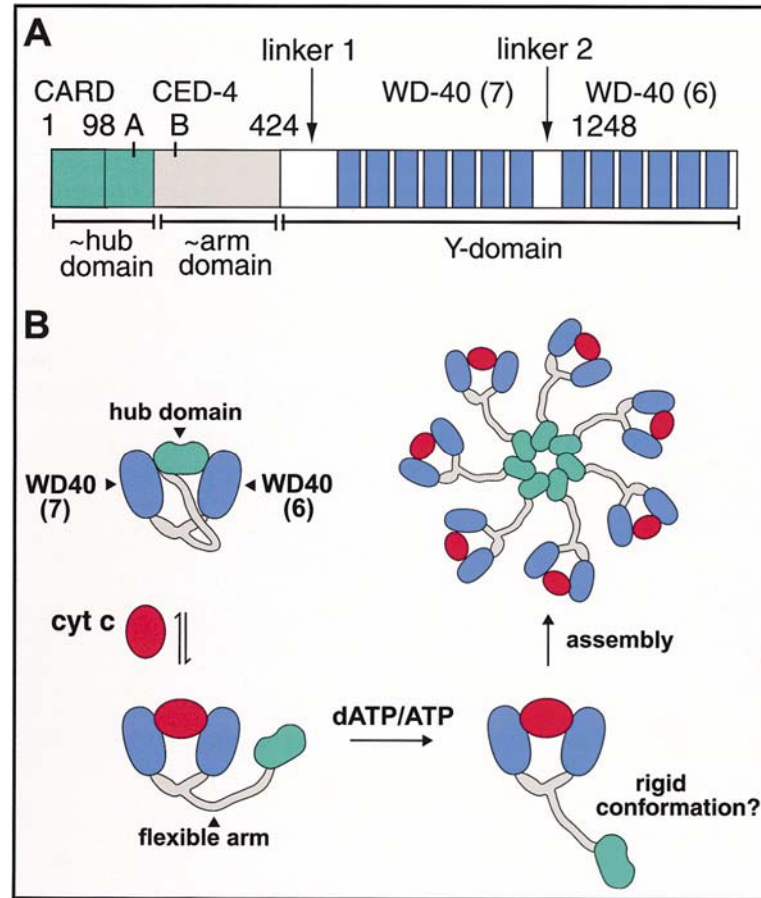

# Electron Microscopy Photographs of Apaf-1 In Complex with dATP and Cytochrome *c*

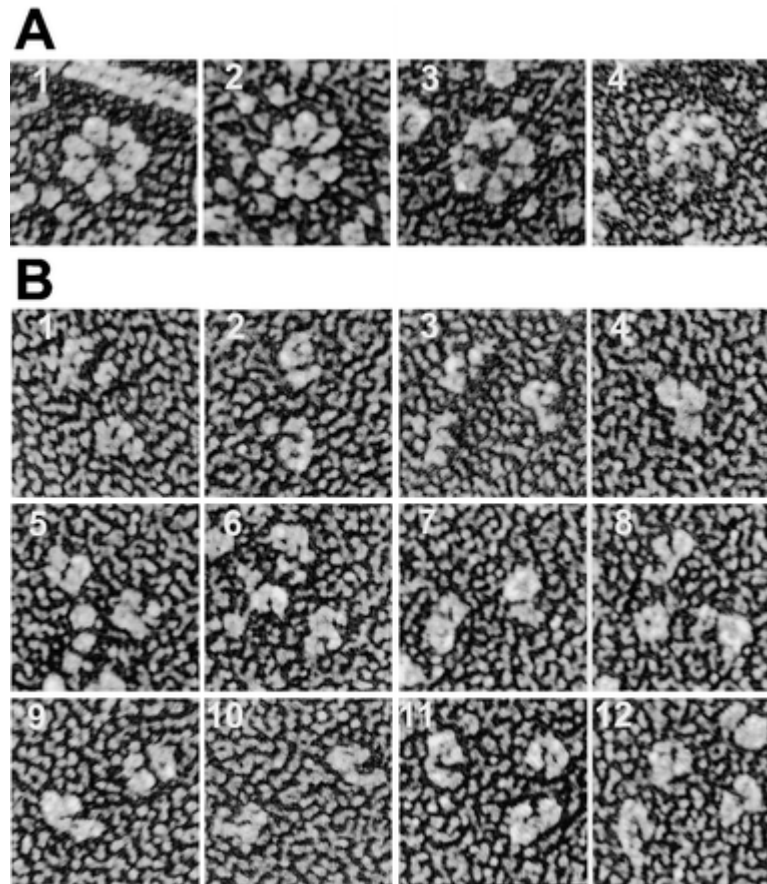

# Apaf-1 Complexes (=Apoptosomes) Form Propeller Structures with Heptagonal Symmetry (=7-fold)

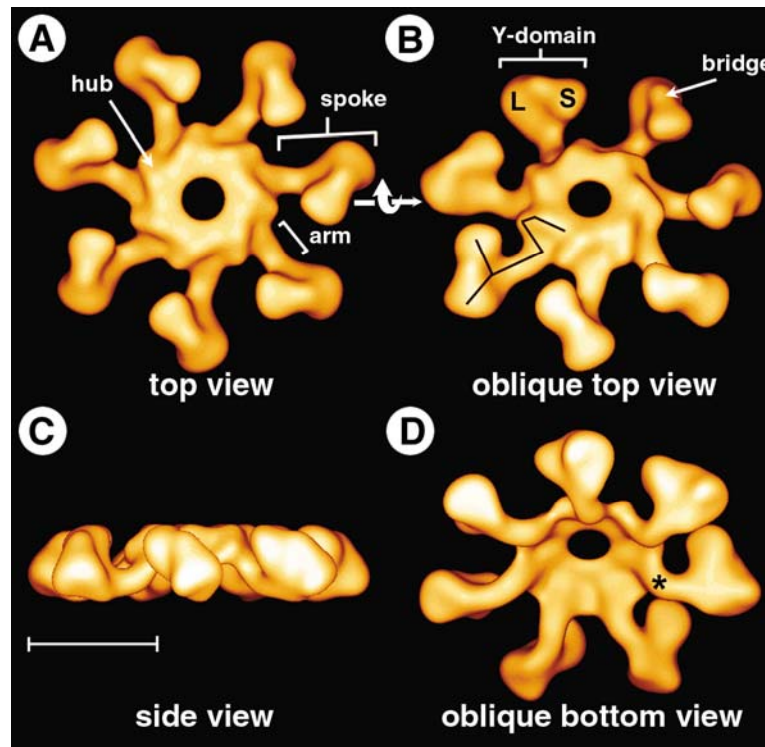

# Components of the Apoptosome are Localized In Defined Parts of the Propeller Structure

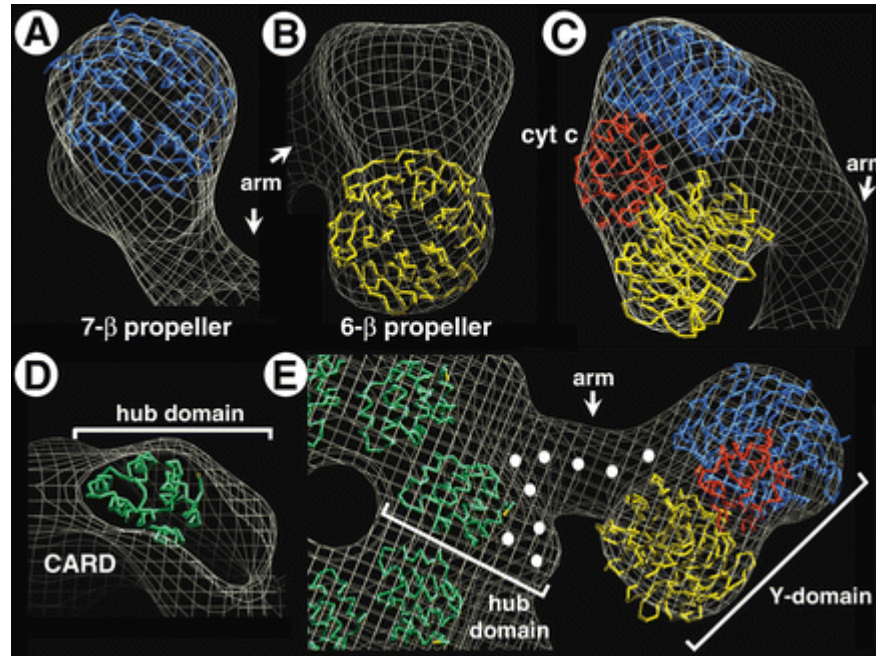

# Caspase-9 Molecules are Localized to the Hub And Form a Dome that is the Basis for the...

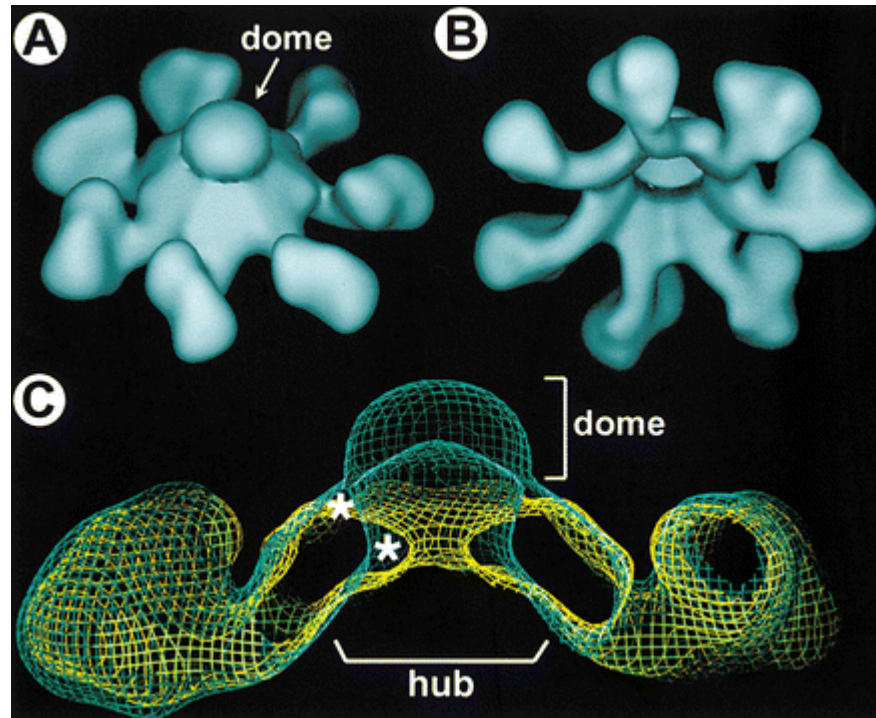

# ...Formation of the '*Evil Oreo*' of Apoptosis

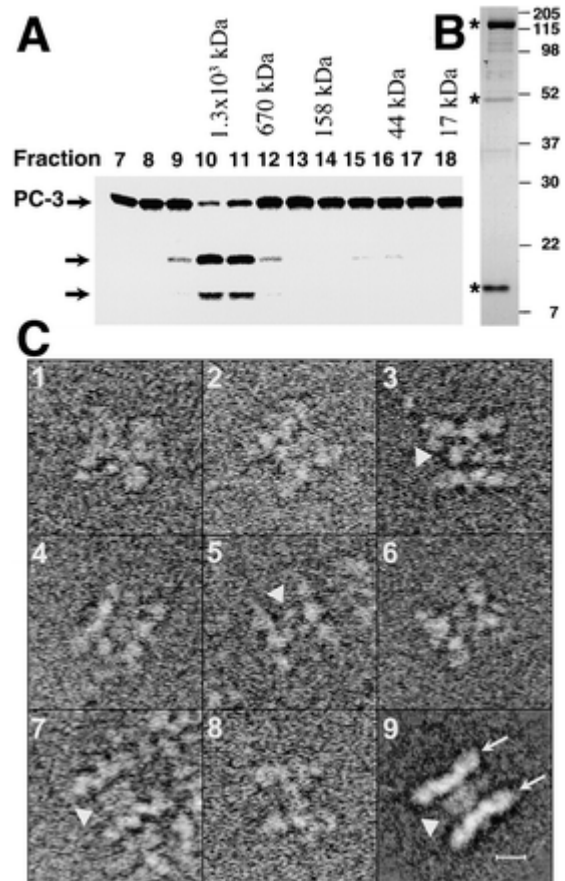

# Caspase Activity is Determined using Fluorogenic Tetrapeptides Resembling Protease Cleavage Sites

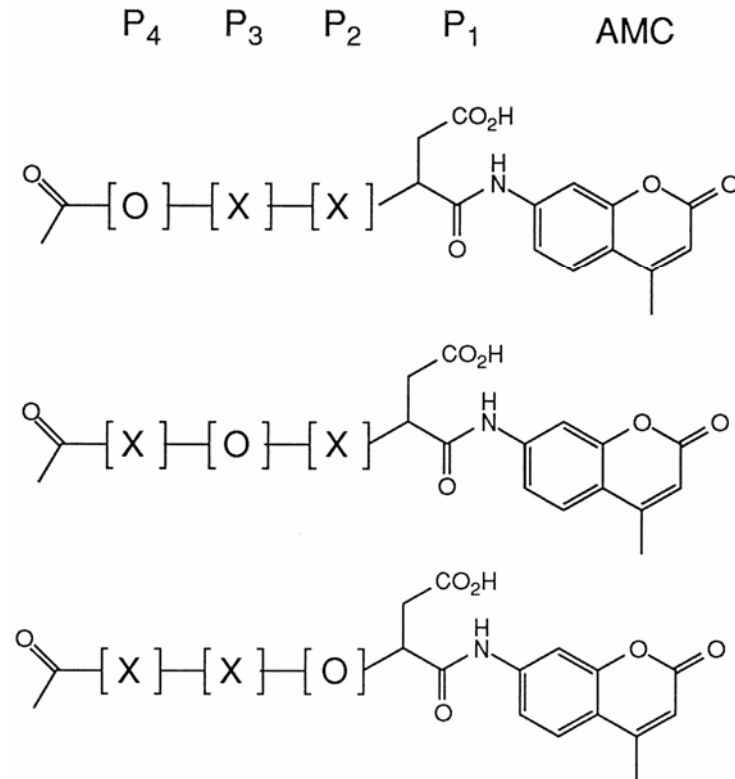

# Systematical Permutations of Tetrapeptide Sequences Reveal Synthetic Substrate Peptides...

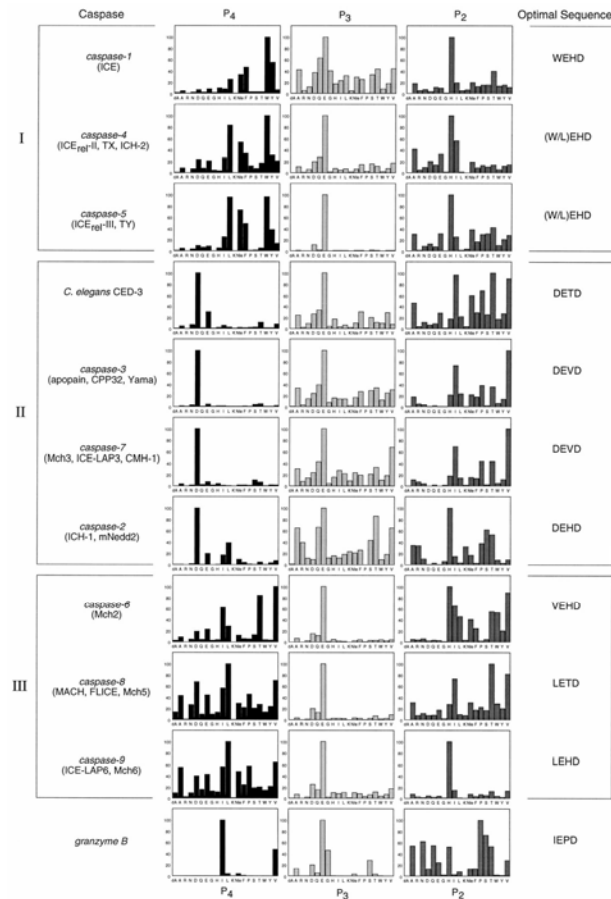

# ...With Increased Specificity for Selected Caspases And Groups of Caspases...

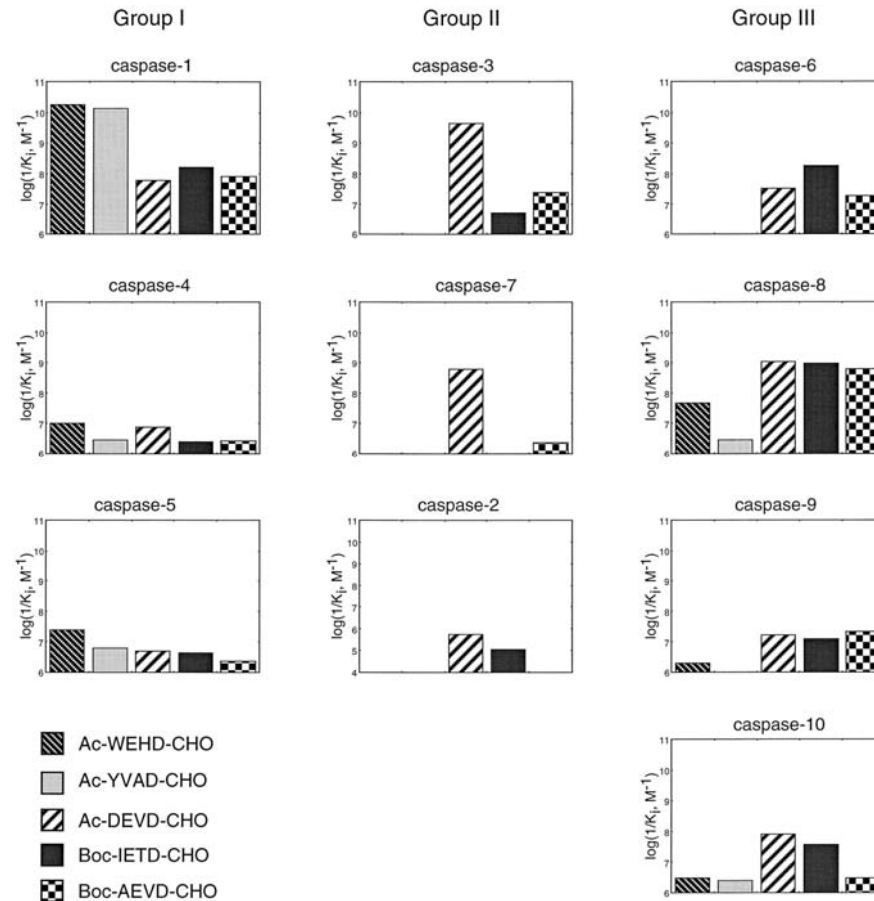

# ...That Form the Rational for the Generation of Peptoid Caspase Inhibitors

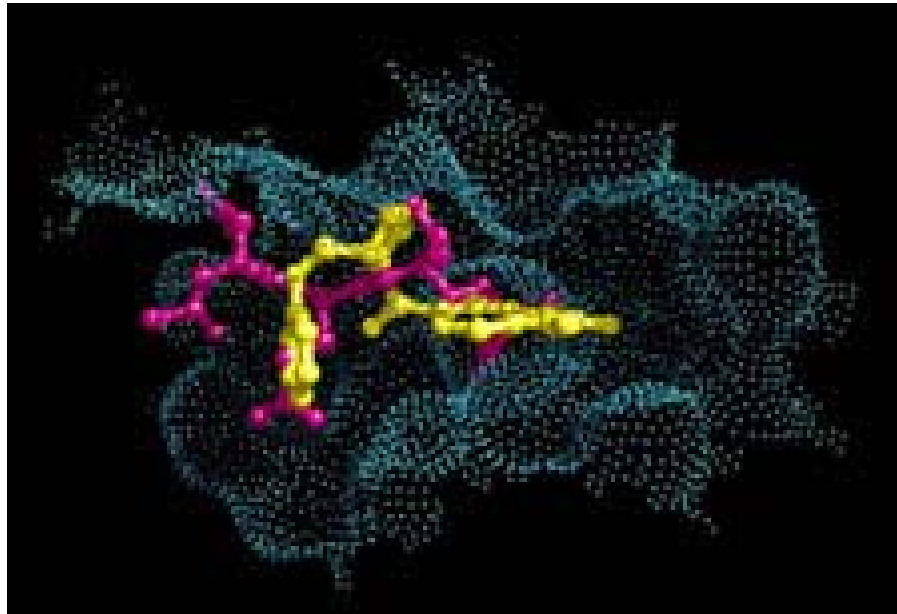

Unfortunately: Limited Practical Use because of Hepatobiliar  $P_1$ -Asp Transporter System (=Secretion)

# *In Summary: Death Receptor Signals (Extrinsic) Induce Caspase-8 Activation while ...*

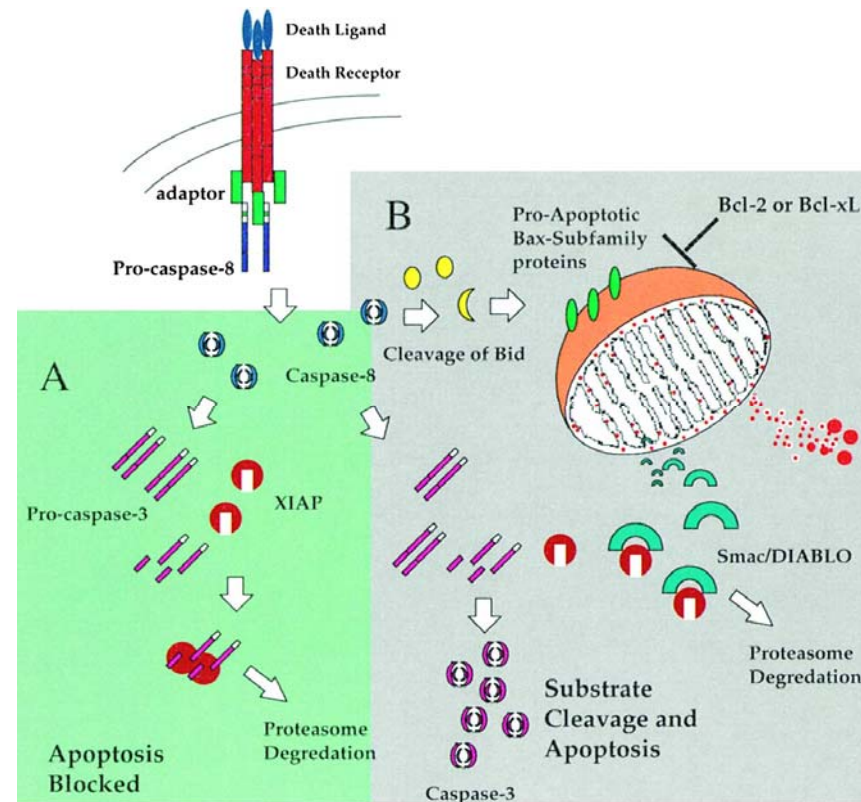

# ...Cellular Stresses (Intrinsic) Cause Mitochondrial Damage Leading to Caspase-9 Activation

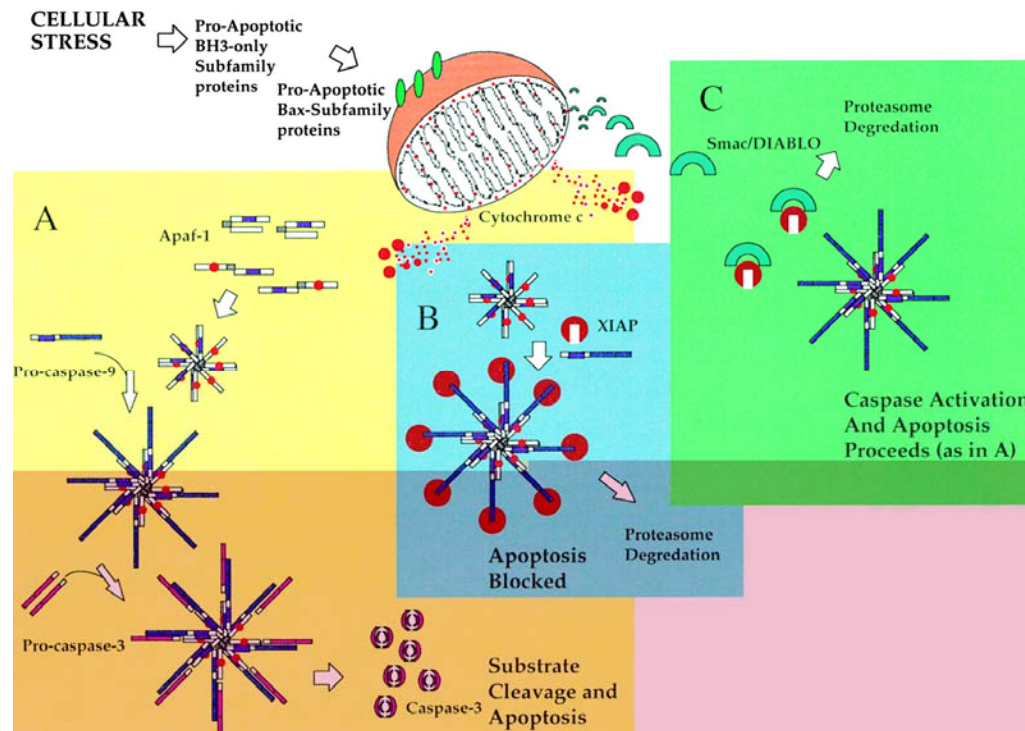

# Other Caspases (Caspase-1,5) are Involved in Inflammatory Cell Responses...

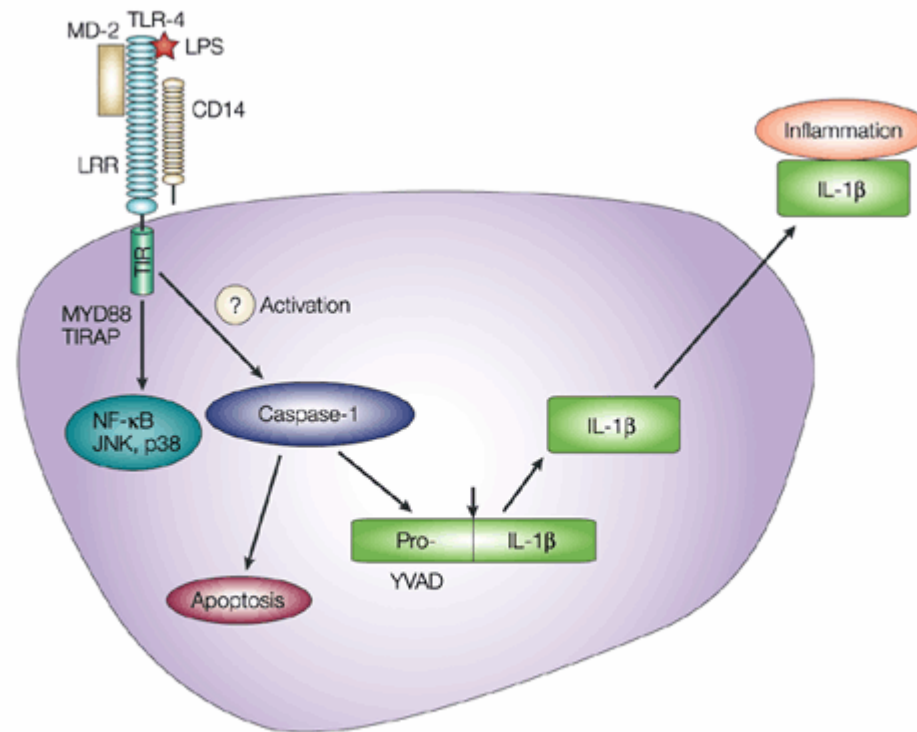

Nature Reviews | Molecular Cell Biology

# ...That Involve Multimolecular Complexes...

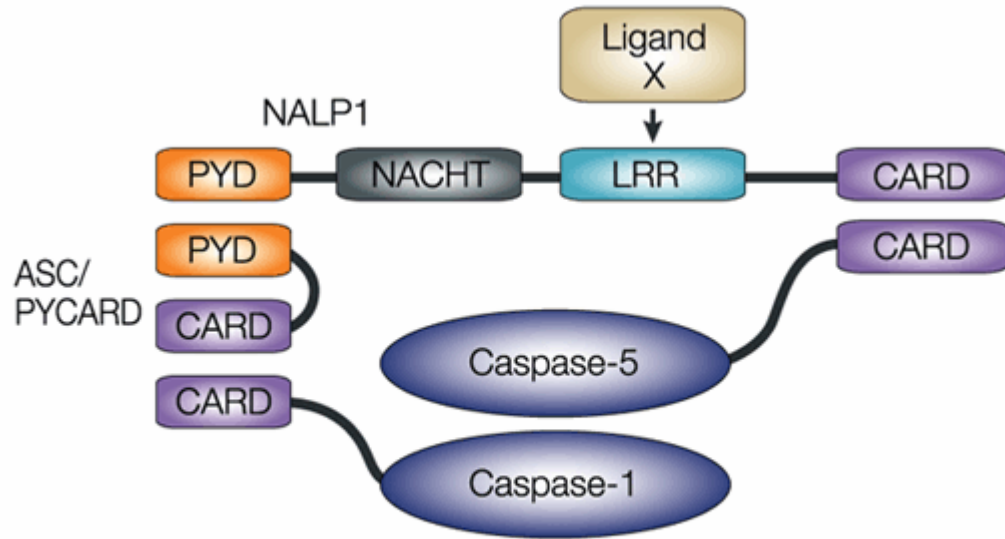

Nature Reviews | Molecular Cell Biology

# ...And Lead to the Assembly of an Inflammasome

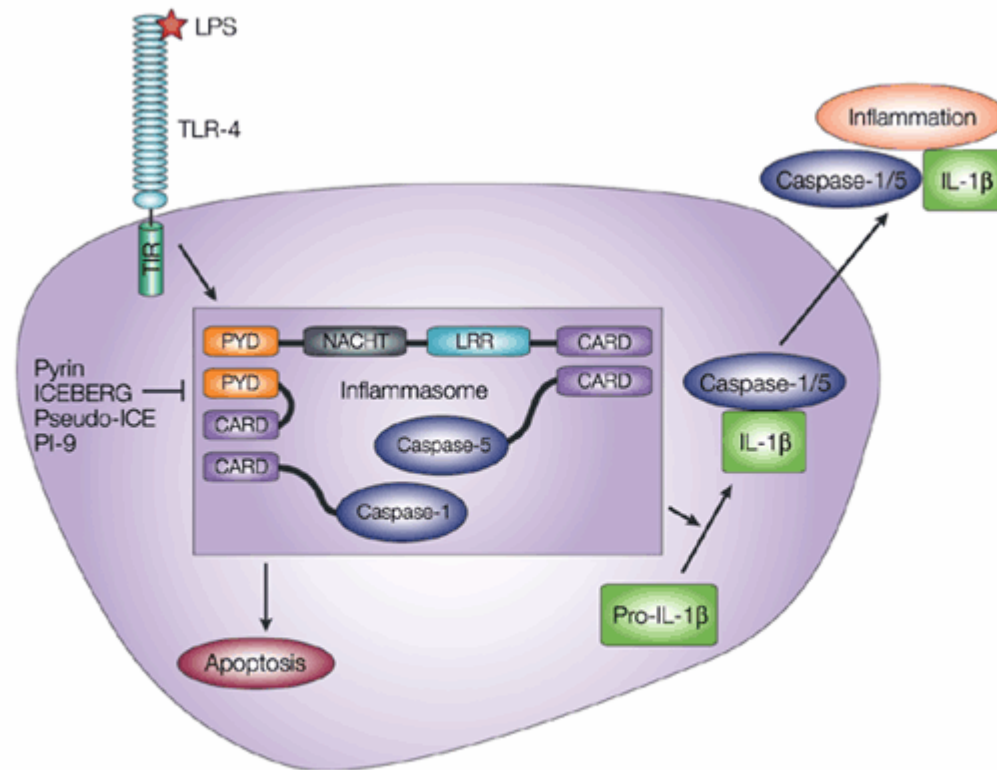

Nature Reviews | Molecular Cell Biology

# Extrinsic Cell Death Pathways Depend on Death-Receptor Ligands such as TRAIL

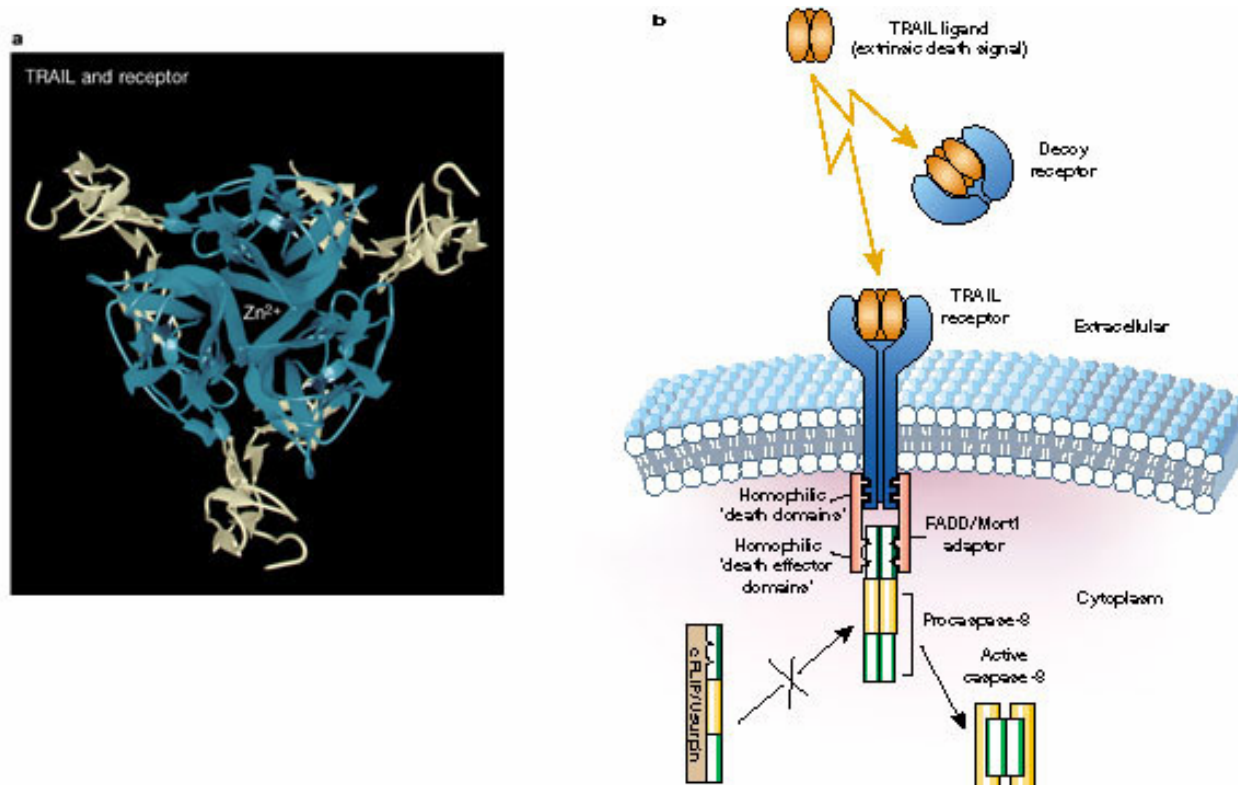

# CD95/Fas/Apo1 → Caspase-8 Activation (=Death)

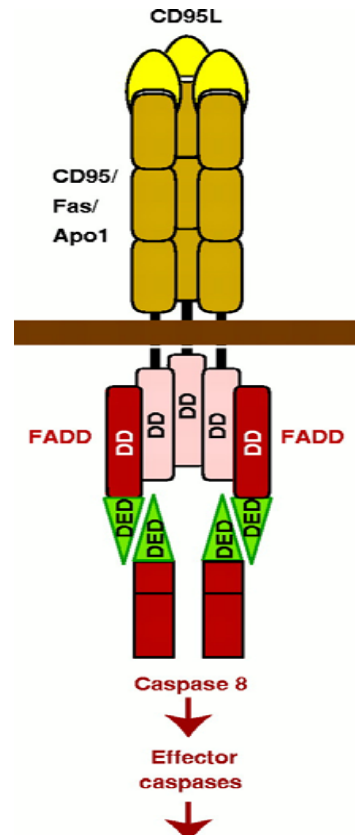

# Apo2L/TRAIL → Caspase-8 Activation (=Death)

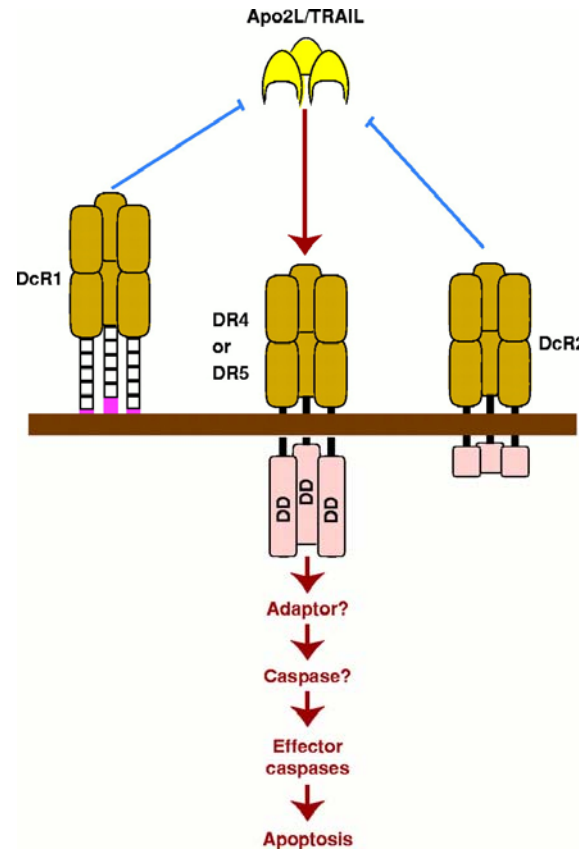

Increased Sensitivity in Cancer Cells (Lack of Decoy Receptors)

# Apo3L/TNF → Caspase-8 Activation (=Death) + NF-κB Activation (=Survival)

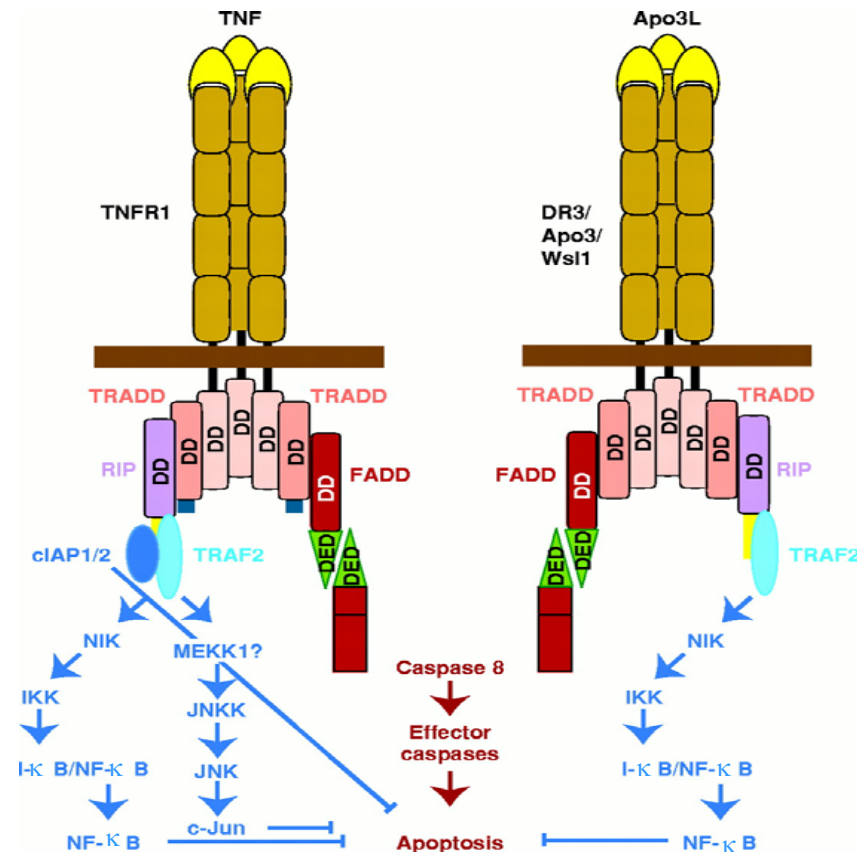

# Targeting the PI3K-Akt Pathway: Rationale and Promise

- Survival signaling by serine-threonine kinases (PTEN/PI3K/Akt)
- Akt functioning in metabolism, cell growth and survival
- Development of Akt inhibitors
- PI3K/Akt signaling as therapeutic target: ongoing clinical studies (CCI-778, RAD001)
- Outlook: DNA damage responses, p53



# Cellular Receptors Initiate Intracellular Cascades

## The TrkA Receptor

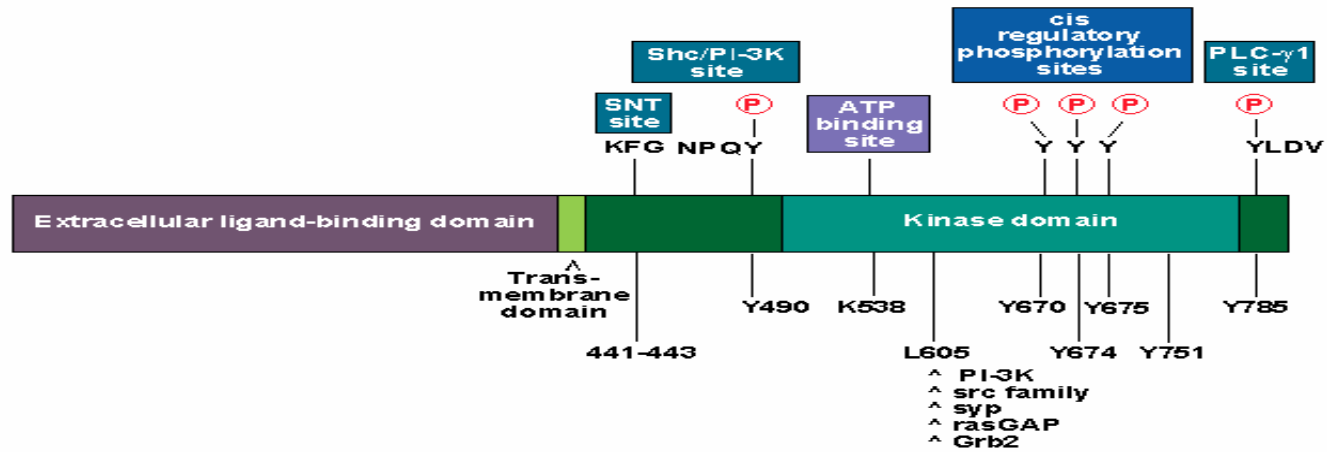

# PtdIns-Dependent Second Messengers Function In Distinct Intracellular Pathways...

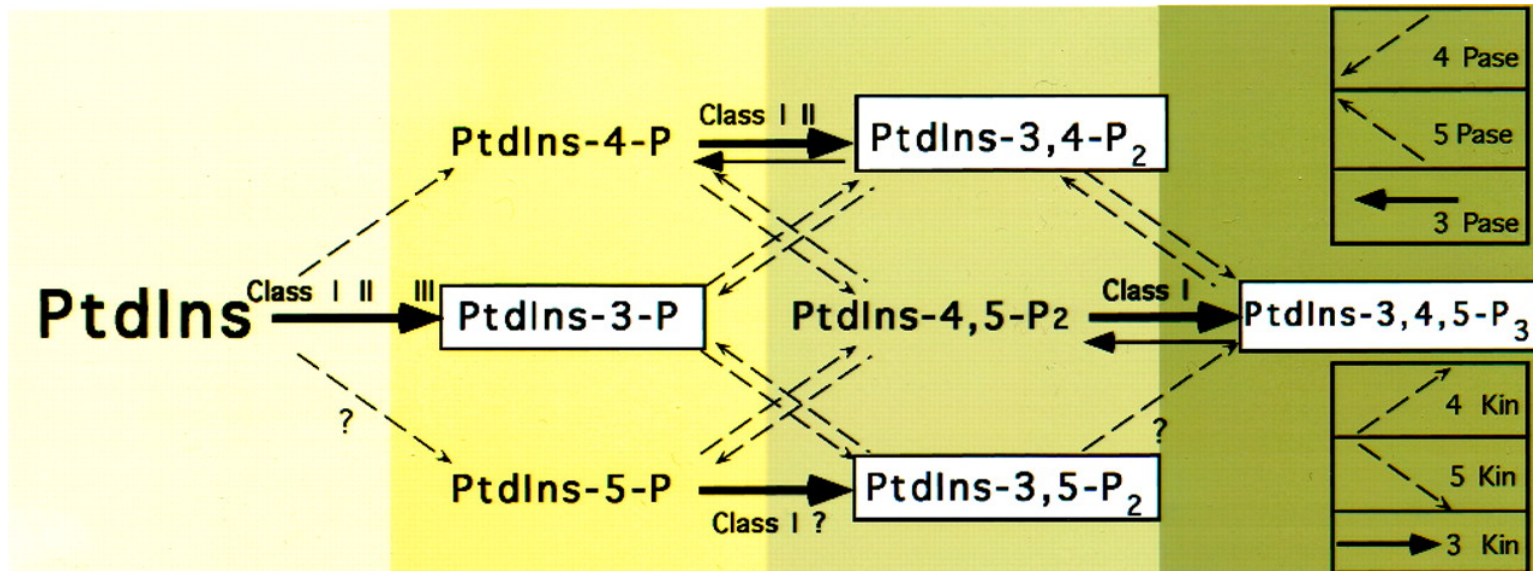

# ... Depending on Distinct Regulatory Domains Of Target Proteins

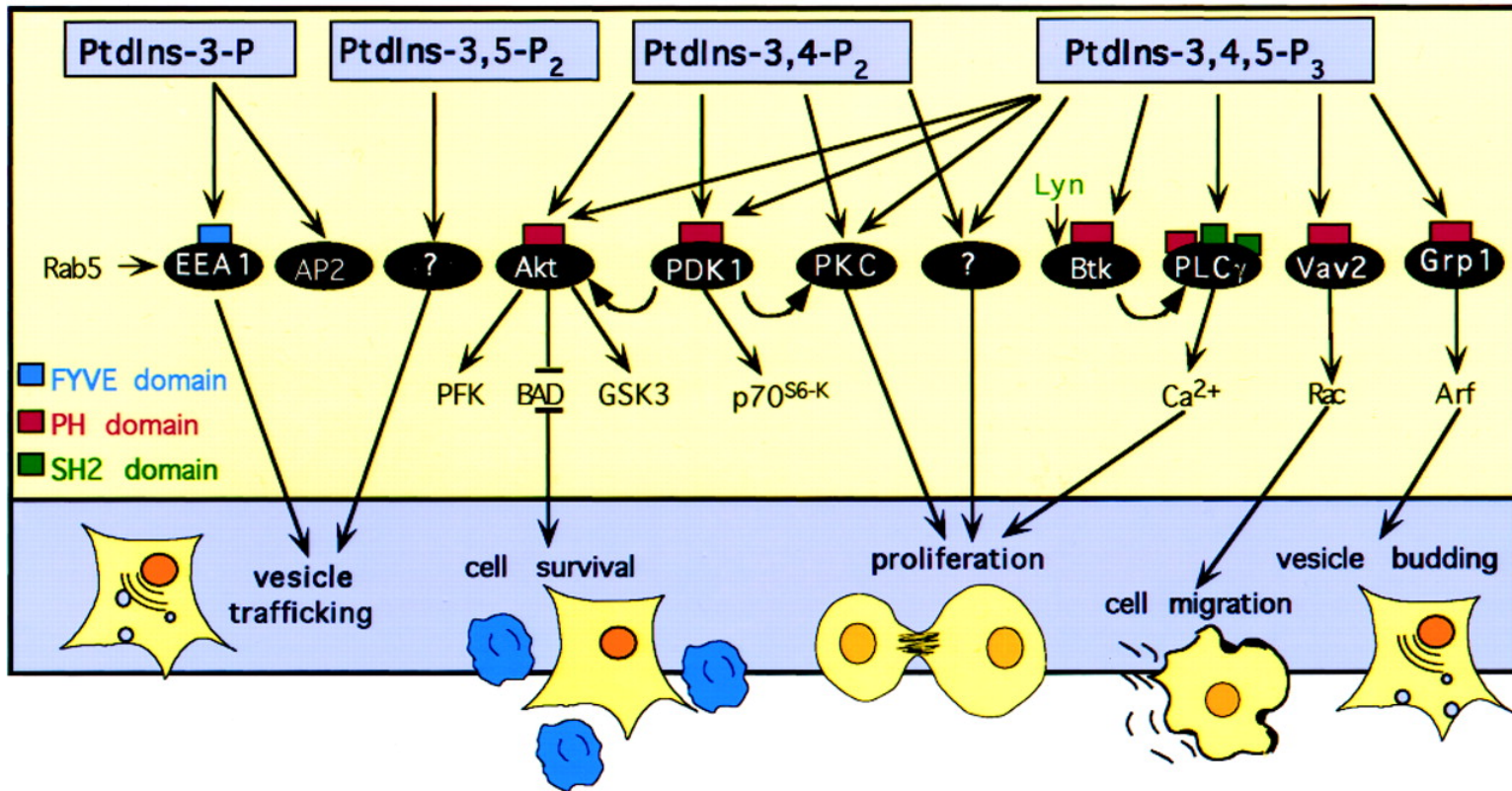

# PIP3-Dependent Cell Responses are Mediated by PTEN/PI3K/AKT

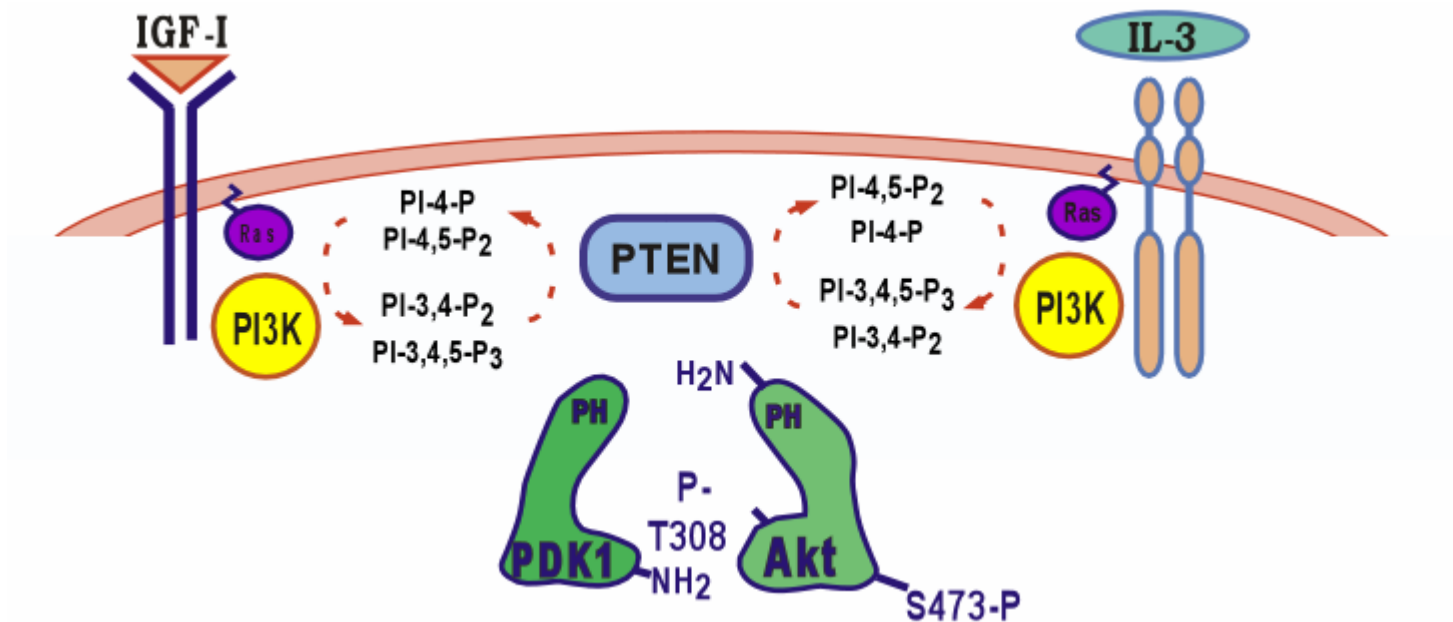

# Sequence Alignment of AGC Kinases

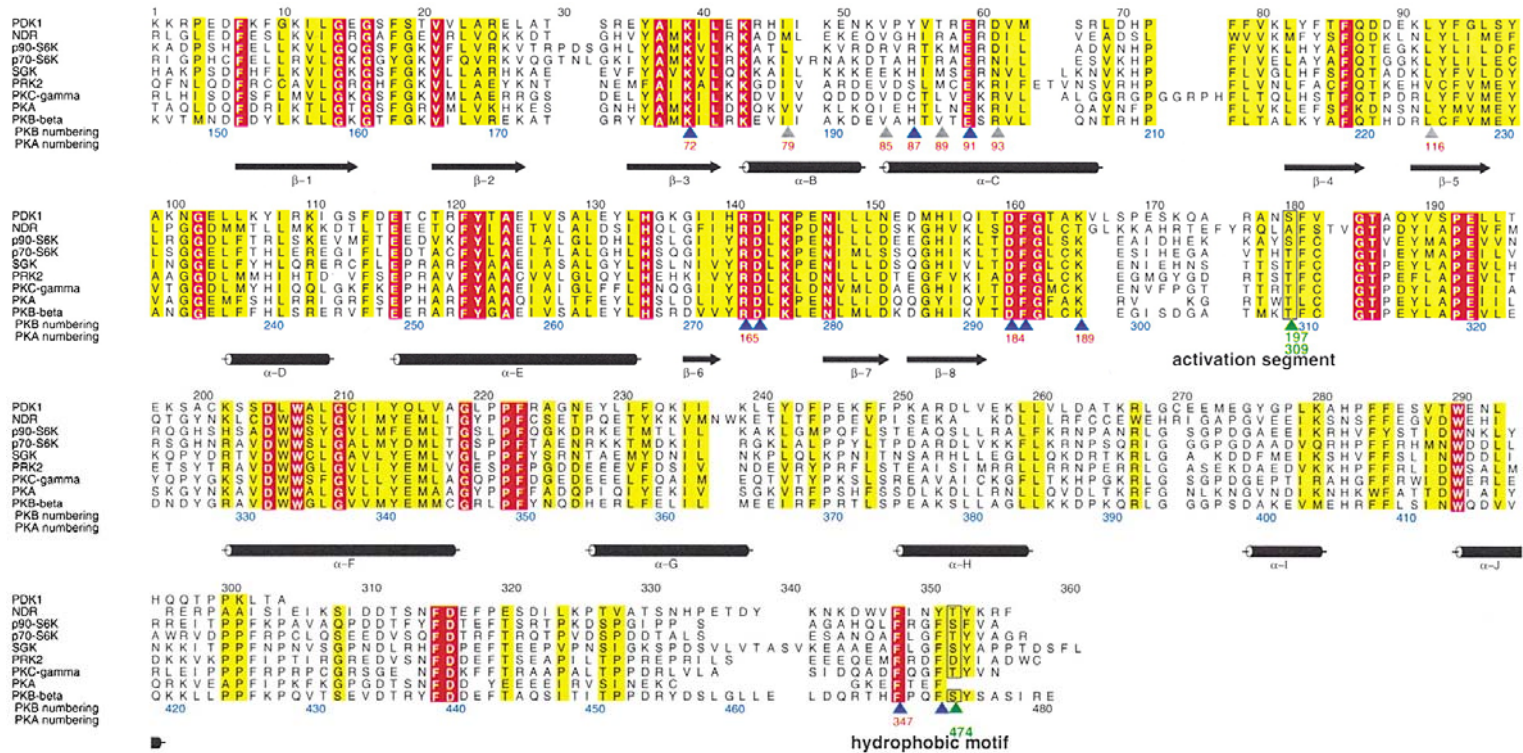

# Structure of Akt in Comparison with PKA

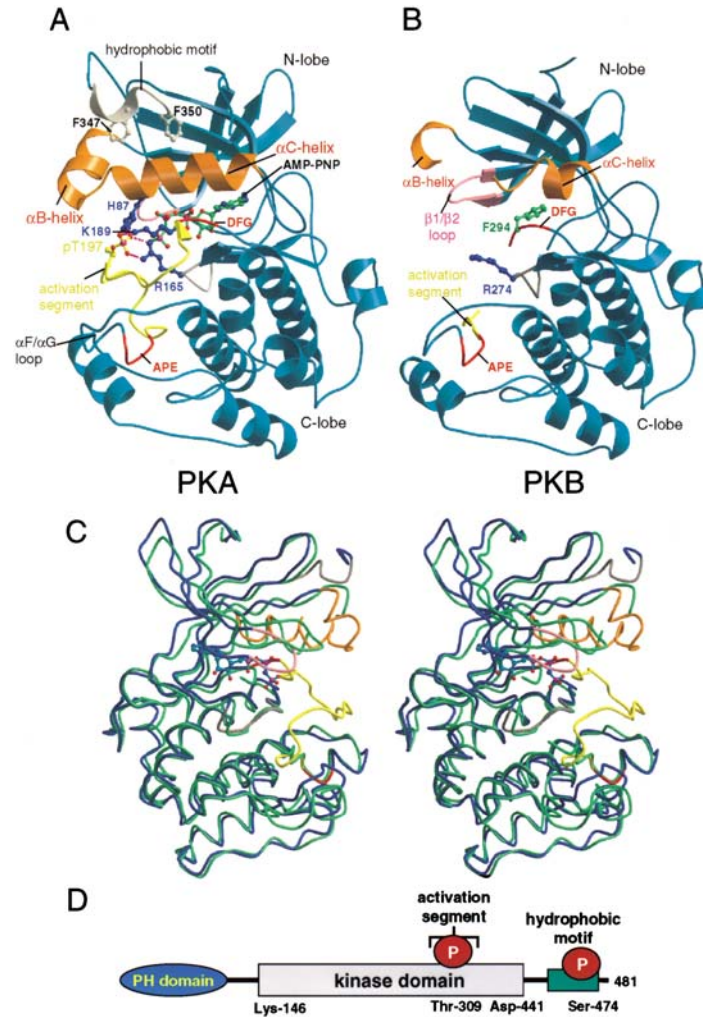

# Structure of the N-terminal lobe

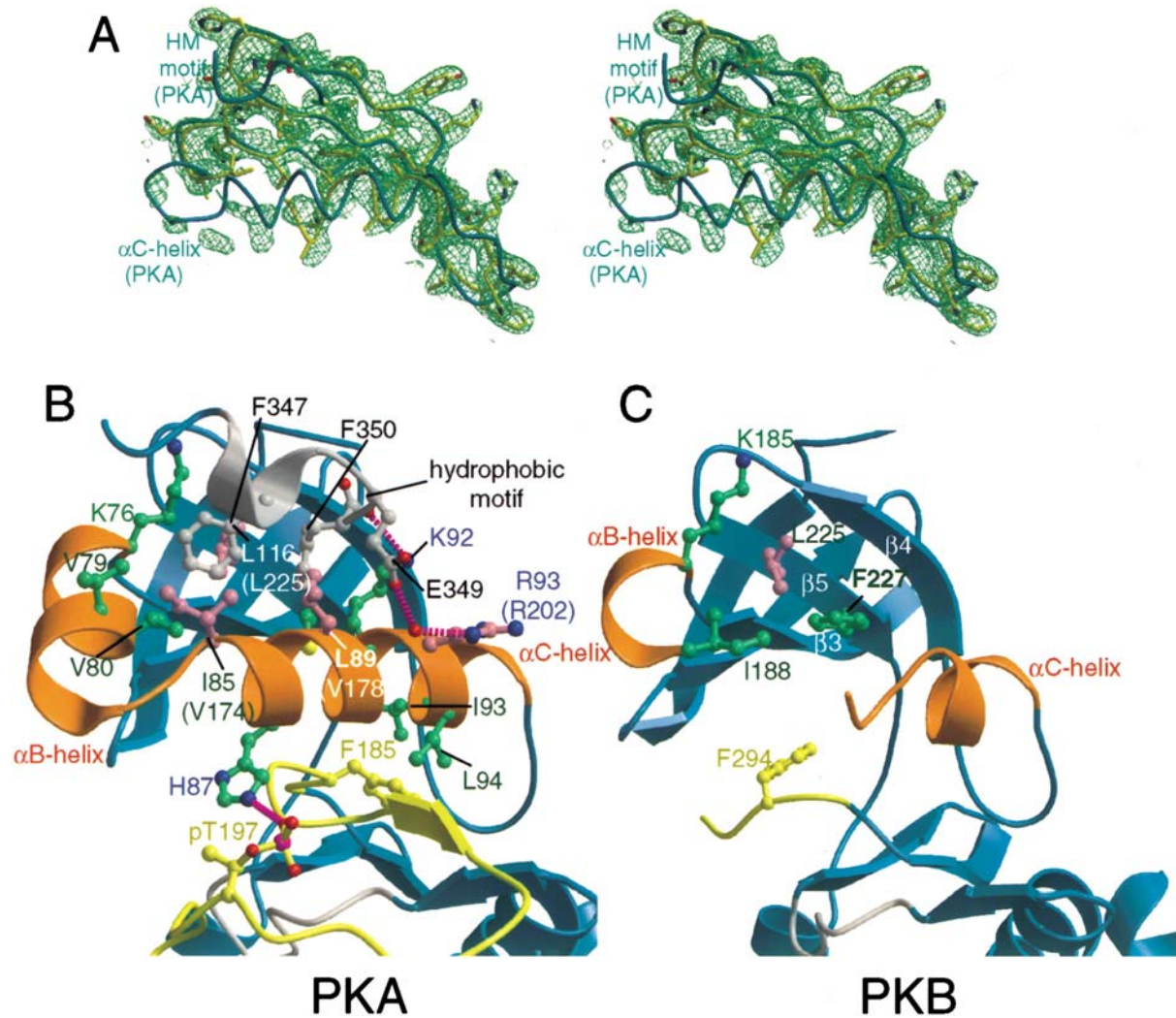

# Role of $\alpha$ C Helix to Stabilize an Active Kinase State

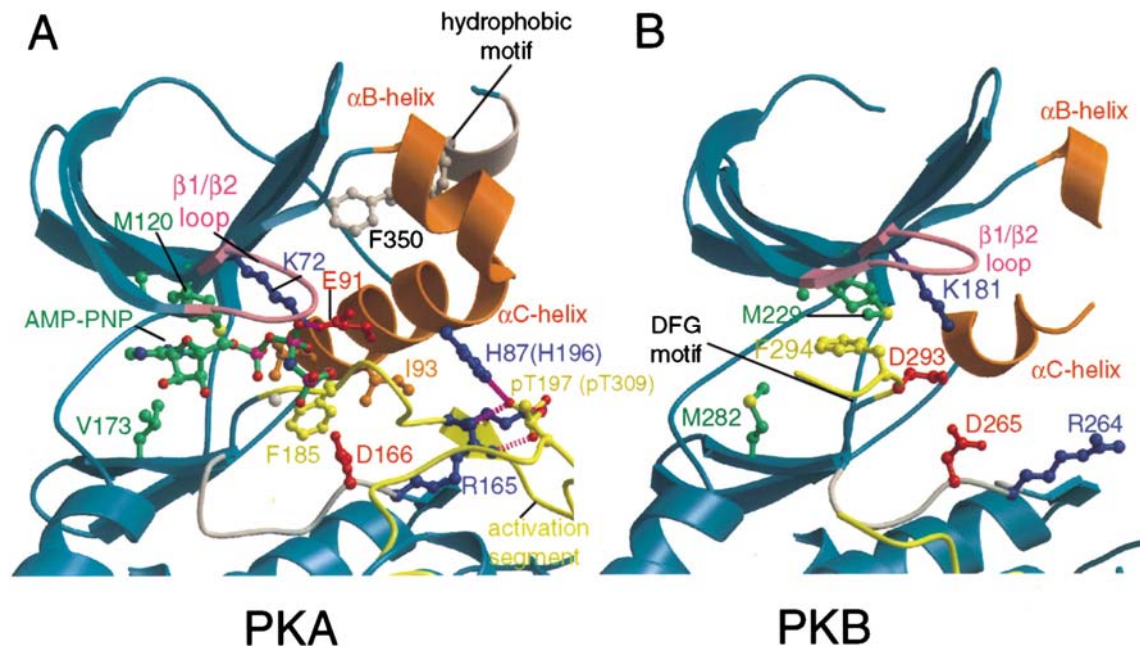

# Conservation of Hydrophobic Motif Binding Channel among AGC Kinases

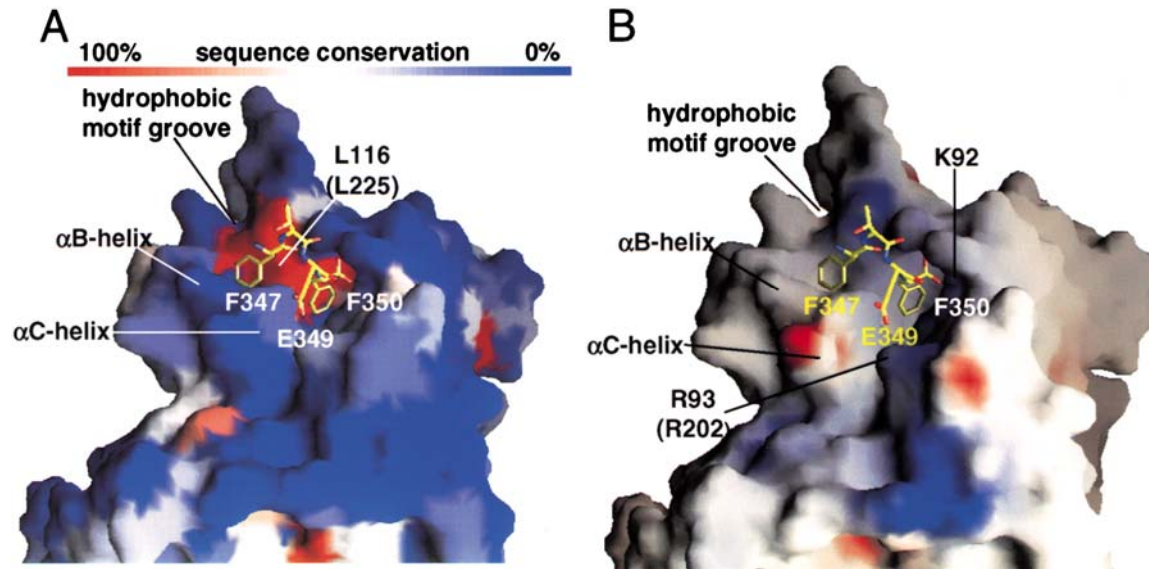

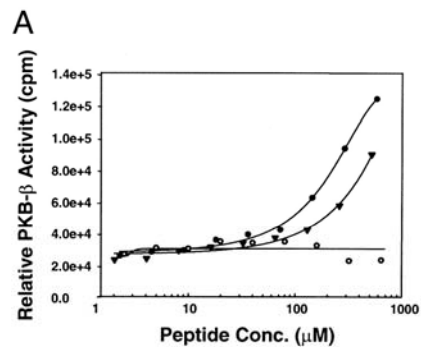

PKB HM-P: GLEELDQRTHFPQ**F**pYSASIRE  
 PKB HM-S: GLEELDQRTHFPQ**F**SYSASIRE  
 PKB HM-D: GLEELDQRTHFPQ**F**DYSASIRE

- : p $\Delta$ PH-PKB- $\Delta$ C + PKB HM-P
- : p $\Delta$ PH-PKB- $\Delta$ C + PKB HM-S
- ▼ : p $\Delta$ PH-PKB- $\Delta$ C + PKB HM-D

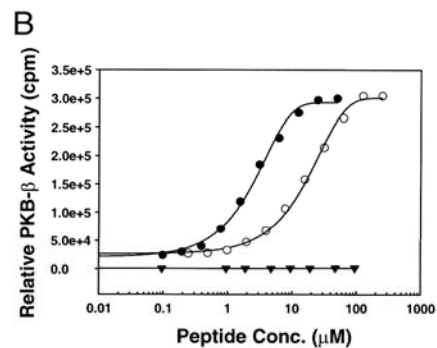

PIFtide: REPRILSEEEQEMFRD**F**DYIADW  
 PIFtide(D->A): REPRILSEEEQEMFRD**F**AYIADW

- : p $\Delta$ PH-PKB- $\Delta$ C + PIFtide
- : p $\Delta$ PH-PKB- $\Delta$ C + PIFtide(D->A)
- ▼ :  $\Delta$ PH-PKB- $\Delta$ C + PIFtide

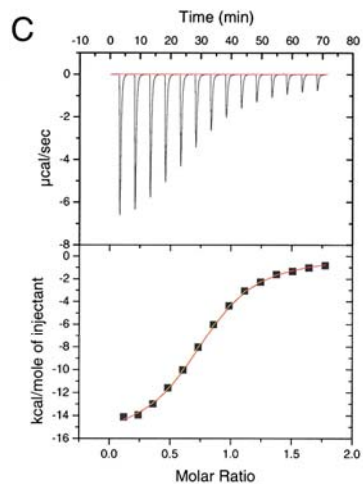

p $\Delta$ PH-PKB- $\Delta$ C + PIFtide  
 $K_d = 6.2 \mu$ M  
 $\Delta G = -6.8 \text{ kcal.mol}^{-1}$   $\Delta H = -16.0 \text{ kcal.mol}^{-1}$   $T\Delta S = -9.2 \text{ kcal.mol}^{-1}$

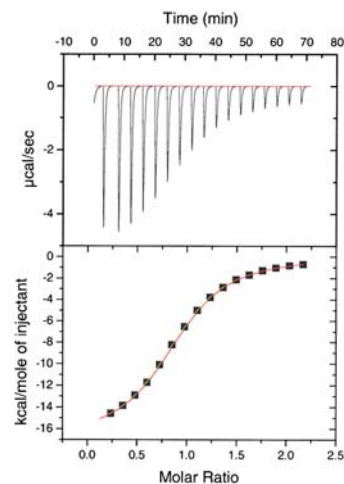

$\Delta$ PH-PKB- $\Delta$ C + PIFtide  
 $K_d = 5.4 \mu$ M  
 $\Delta G = -6.9 \text{ kcal.mol}^{-1}$   $\Delta H = -16.9 \text{ kcal.mol}^{-1}$   $T\Delta S = -10.0 \text{ kcal.mol}^{-1}$

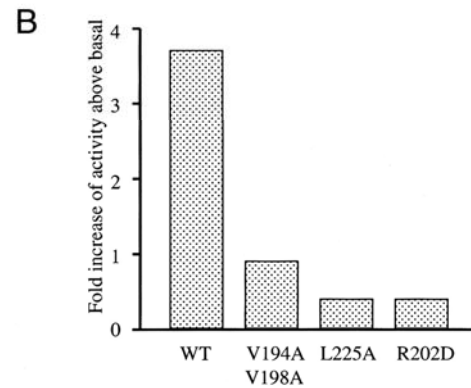
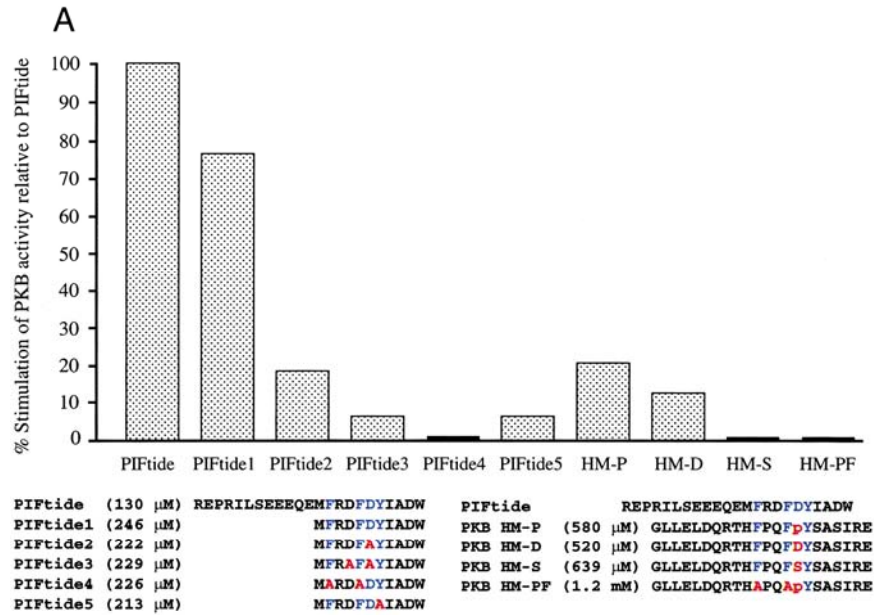

# PTEN/PI3K/AKT Signal Transduction is Evolutionarily Conserved

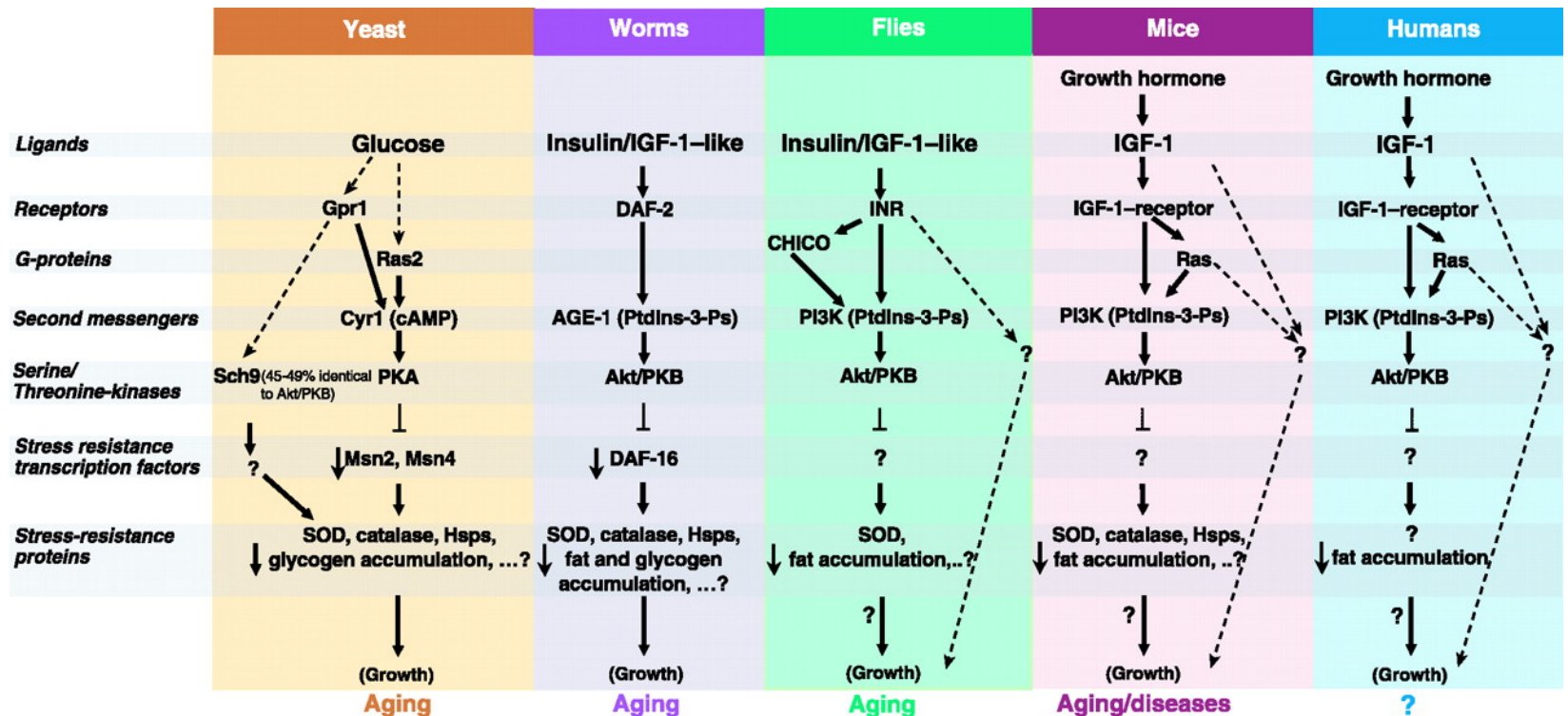

# Loss of AKT Signaling Leads to Lifespan Extension and Reduced Cell Size (=Smaller Organisms)



Yeast (sch9) → Fly (Dakt) → Mouse (Akt1,2,3)

# Decreased Akt Gene Function = Mini-Mice

Akt1 KO  
(~20% smaller)

Akt1 wt  
Littermate



# Multiple Cell Functions are Mediated by PTEN/PI3K/AKT

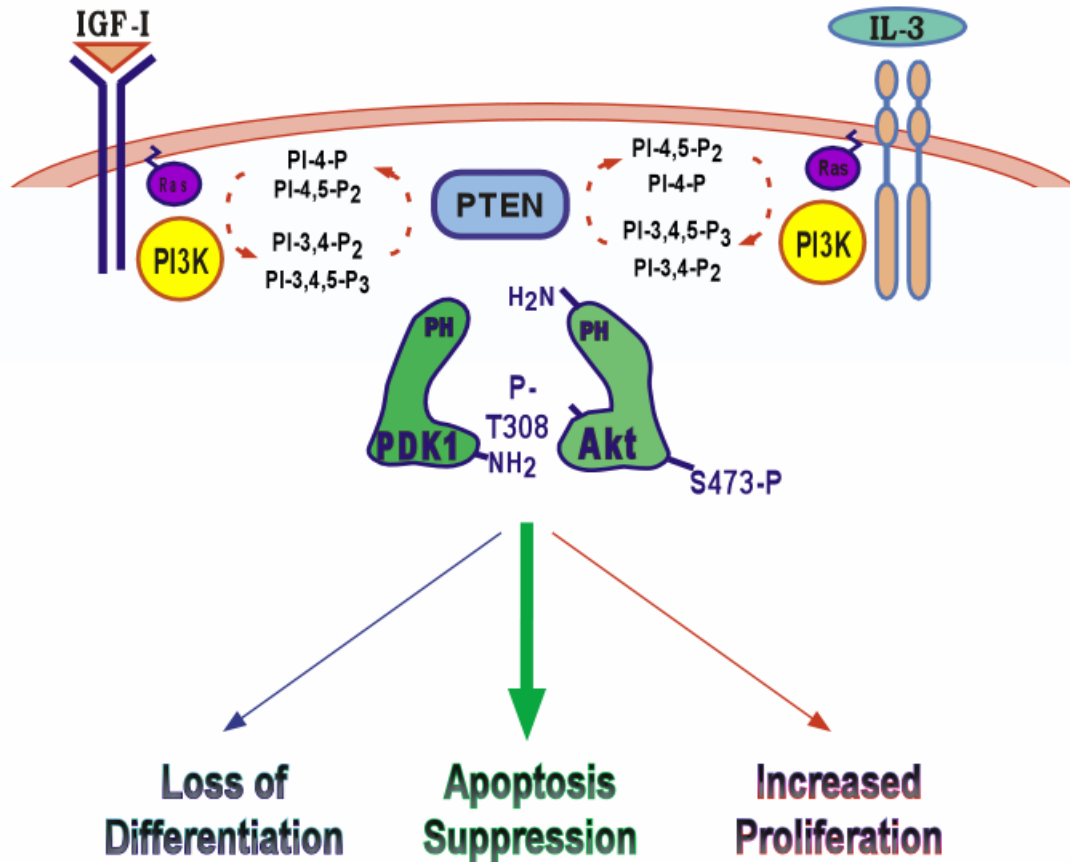

# Increased Strength of AKT Signaling = Cancer

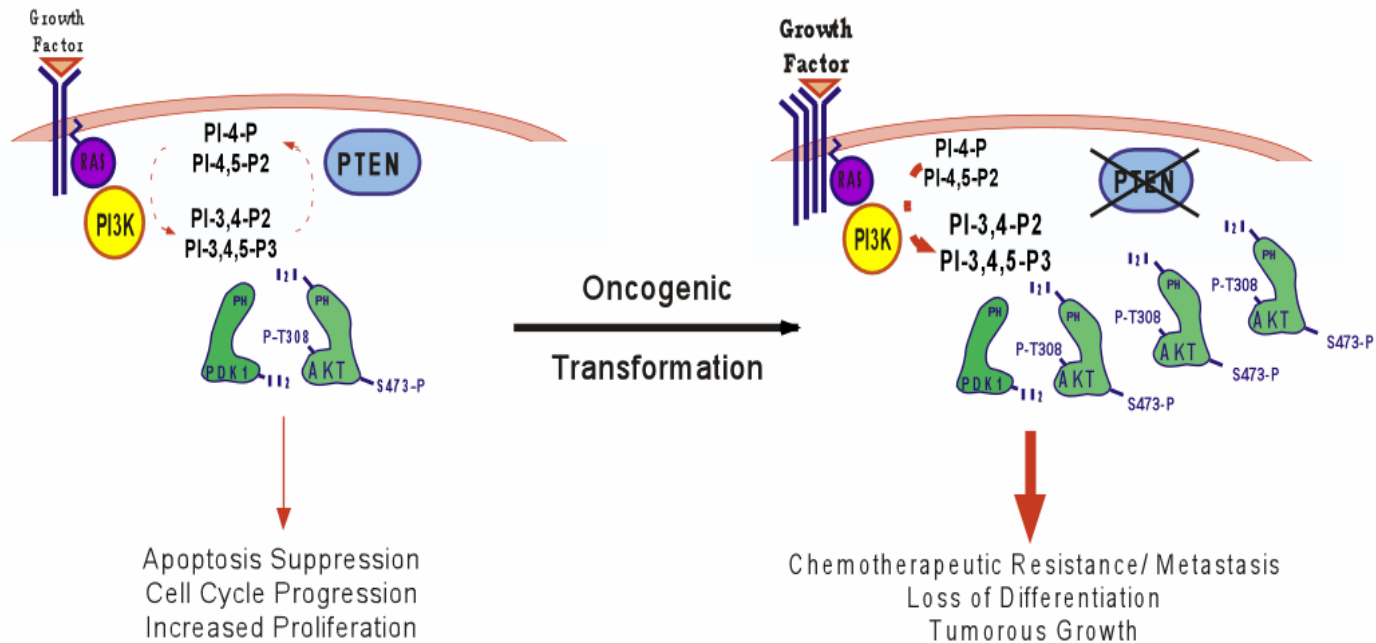

# AKT Regulates Distinct and Conserved Protein Substrates...

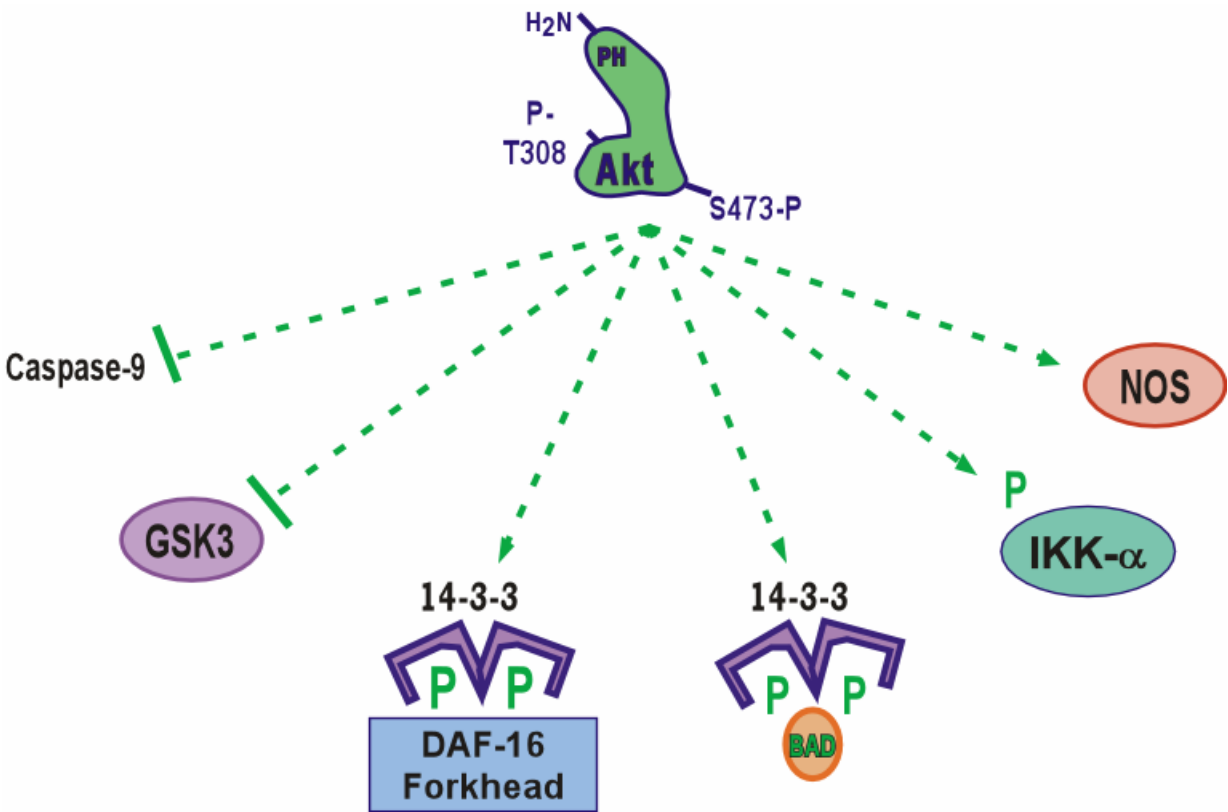

...Including mTOR and FoxO-type transcription factors

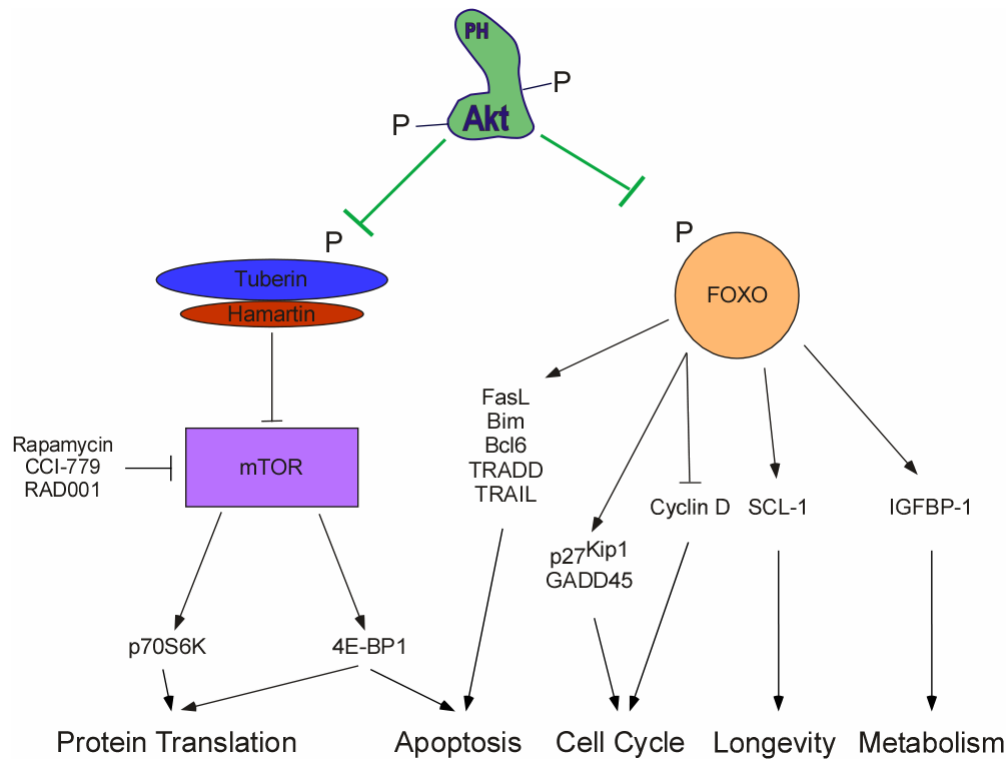

# Lymphomagenesis as a Model of Clinical Cancer Treatment

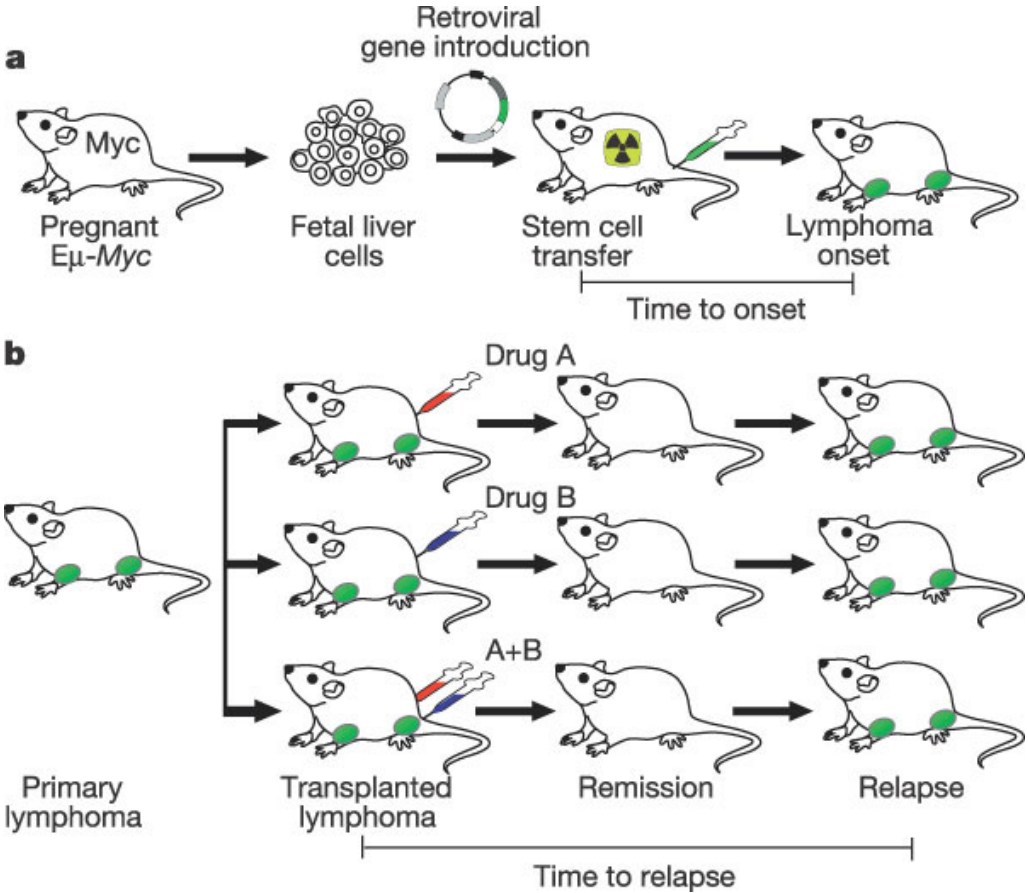

# Akt Promotes Chemoresistance *in vivo*

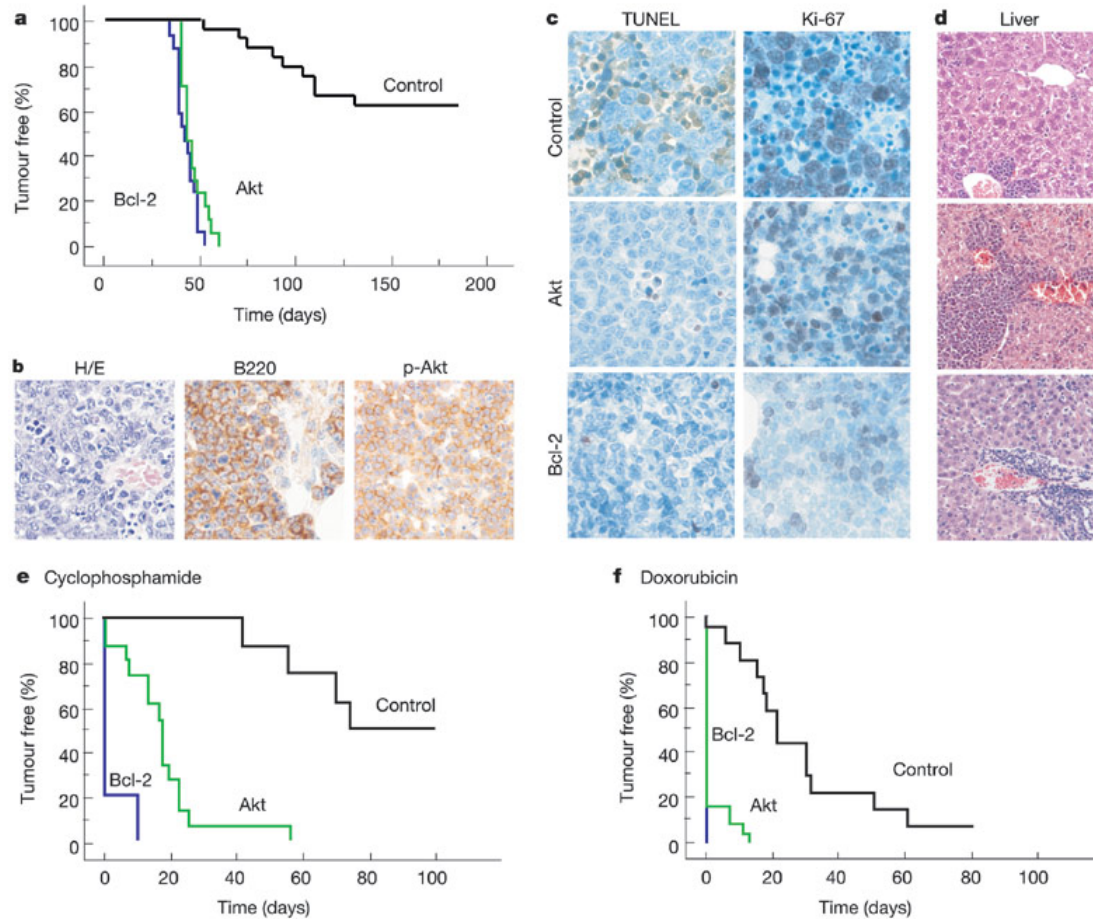

# Rapamycin Reverses Akt-mediated Chemoresistance

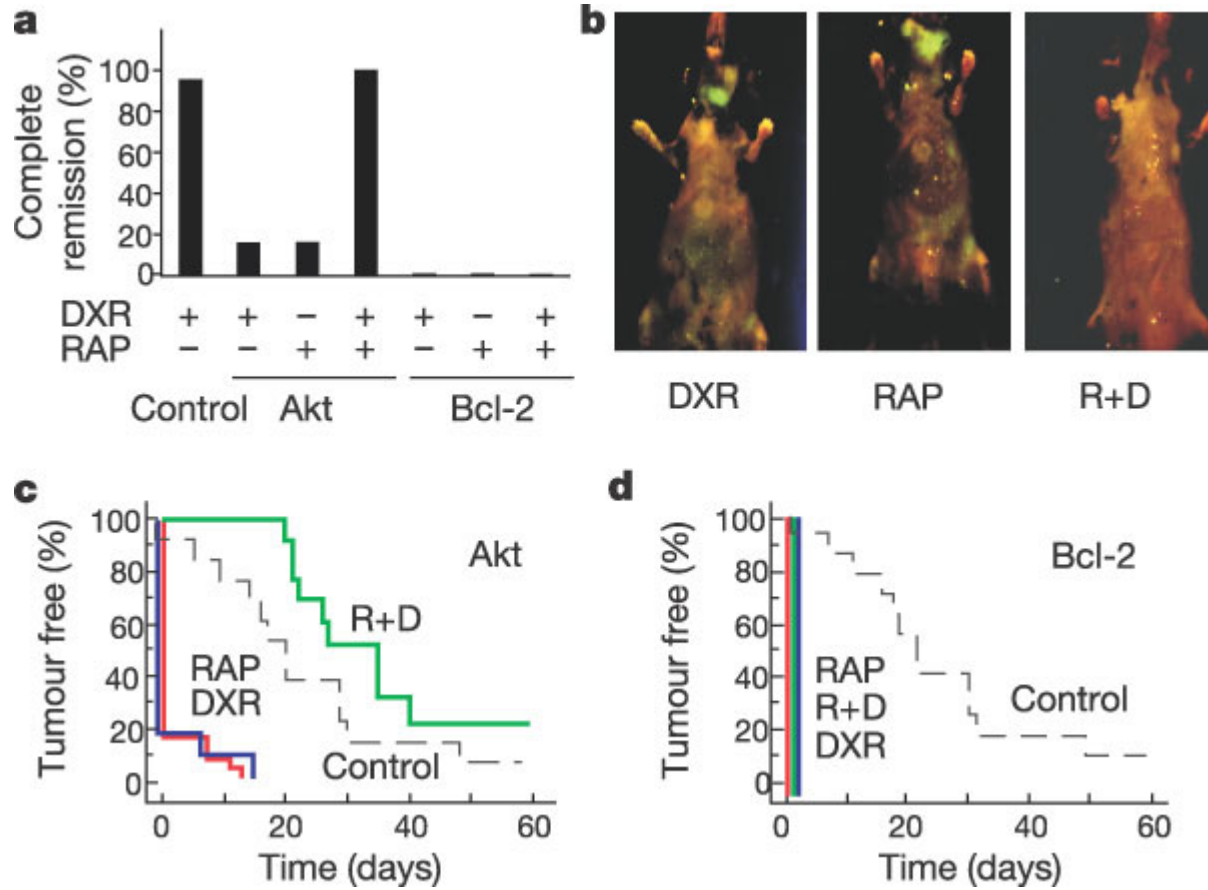

# Akt as Drug Targets

- PI3K Inhibitors (LY294002, wortmannin)
- mTOR Inhibitors (rapamycin, CCI-778, RAD001)
- Natural plant compounds (curcumin, degeulin) – do not inhibit PI3K but inhibit cancer cell proliferation
- 1L-6-hydroxy-methyl-chiro-inositol 2(*R*)-2-*O*-methyl-3-*O*-octadecylcarbonate, D-3-deoxy-phosphatidyl-myo-inositol  
= PH domain targeting compounds
- Sequence-specific design of kinase inhibitors (Keryx Biopharmaceuticals)
- Azepan Derivatives (Roche)
- Fragment-based drug discovery (Astex)  
= Kinase domain targeting compounds

# Outlook: DNA Damage Responses

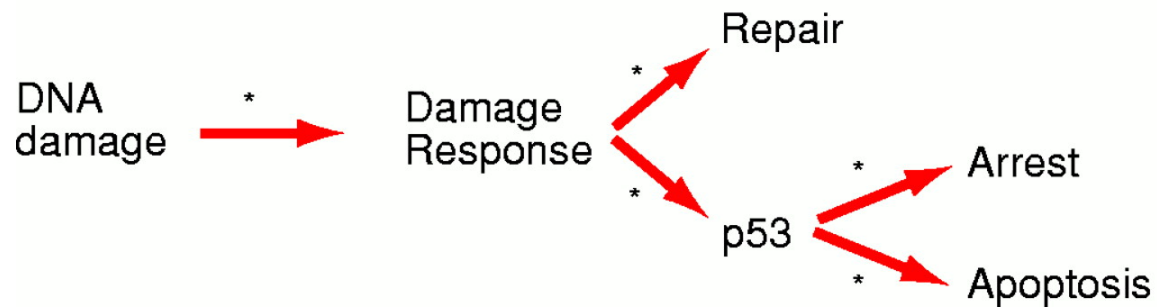
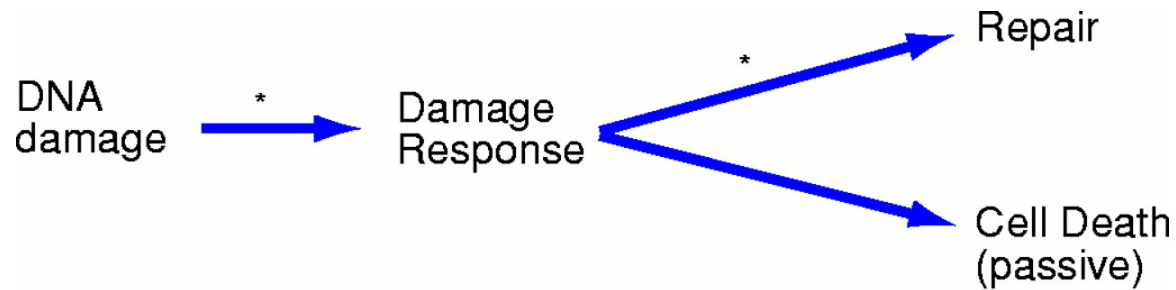

# Outlook: Role of p53

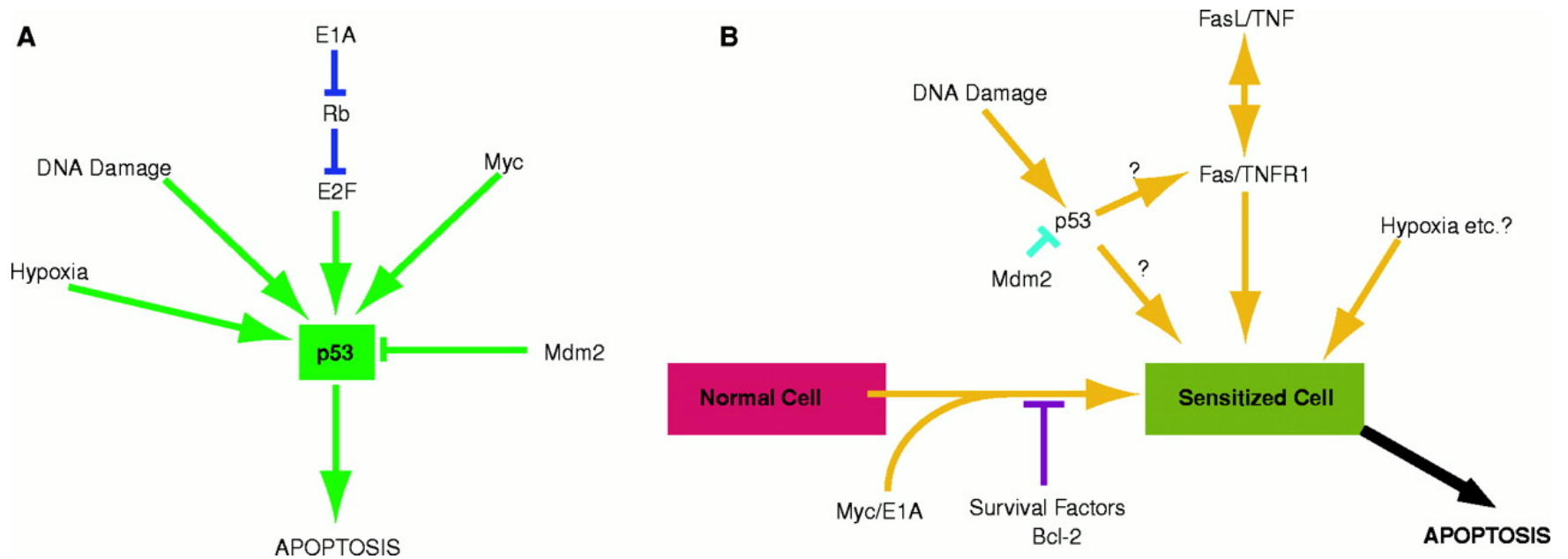

# WHY BRAIN CELLS REALLY DIE

Every sitcom watched leaves a small deposit of crud inside brain cells, which eventually clog up and die.



You pick up a beauty magazine and realize, once again, that looks are everything. Two hundred thousand brain cells commit hari-kari.



Any argument with your kids causes massive brain-cell implosion.



Running on a treadmill: great for the heart, but shakes brain cells loose, which then fall out of your ears.

