

# TIPPING MECHANICS TREATMENT

Malcolm E. Meistrell, DDS  
Professor of Clinical Dentistry

Division of Orthodontics  
School of Dental and Oral Surgery  
Columbia University

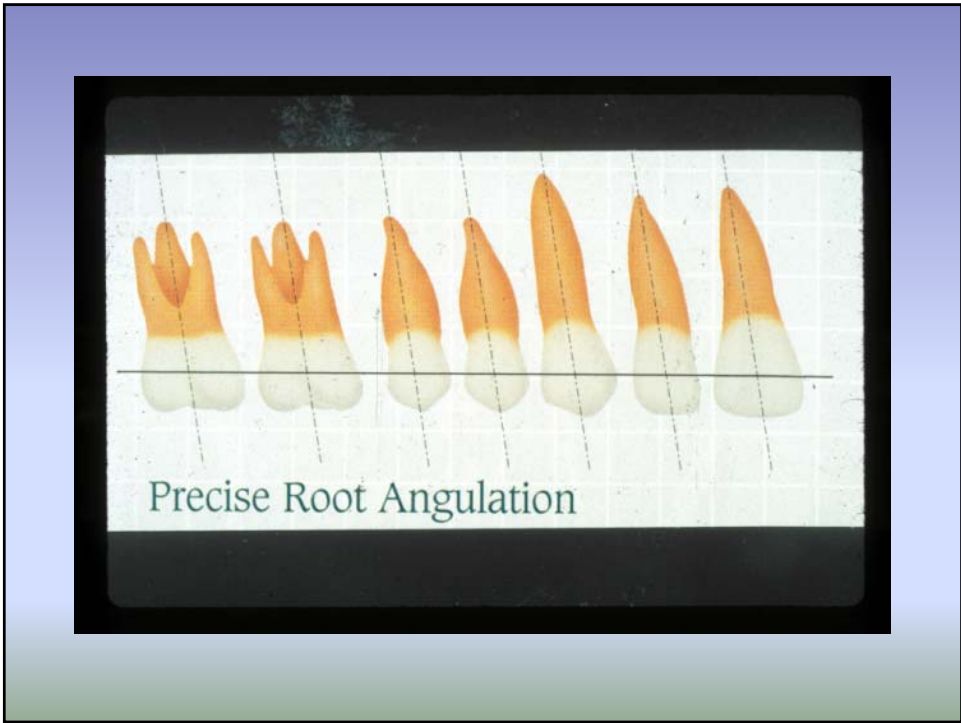

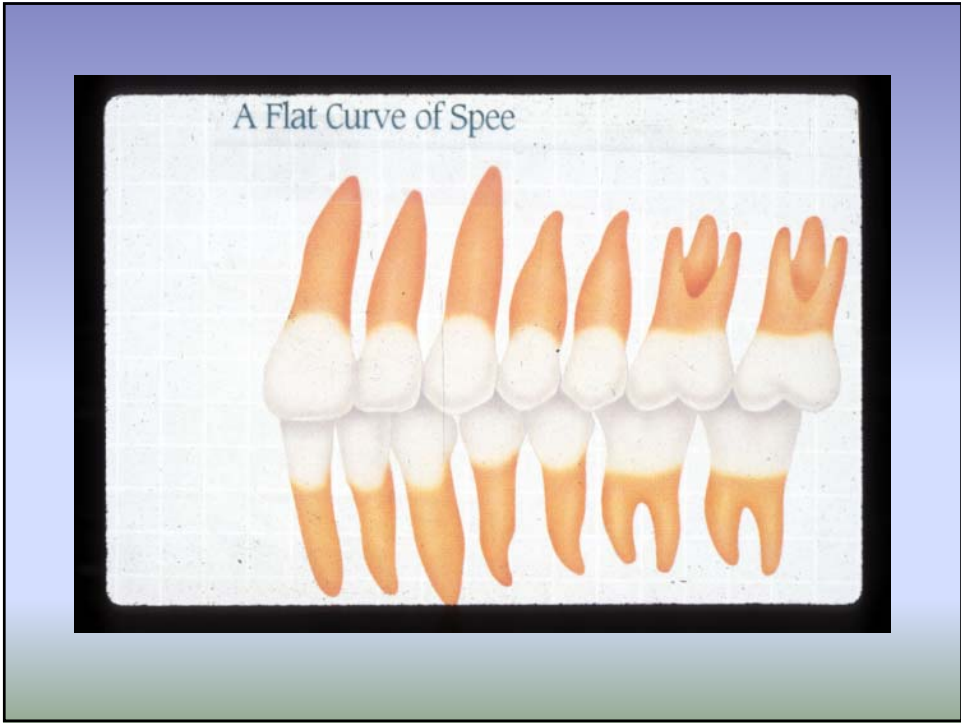



## Goals

## **STAGE I**

Unravel  
Open bite  
Class I Position of molars and canines  
Correct Rotations  
Correct Crossbites  
Level Occlusal Plane

## **STAGE II**

Close Spaces  
Overcorrect class I Relationships  
Maintain all goals achieved in Stage I

## **STAGE pre- III**

Maintain all goals achieved in Stages I & II

Correct occluso-gingival relationships of  
Premolars

Correct bucco-lingual relationships of  
Premolars

## **STAGE III**

Upright

Torque

Maintain all goals achieved in Stages I & II

## **STAGE IV**

Establish ideal occlusion

Establish ideal esthetic relationships

## **TIP EDGES ADVANTAGES**

- Ease of wire changes
- Control
- Rapid changes in the vertical dimensions
- Midline integrity protected/preserved
- Improved rotational control

## **WHY TIP EDGE?**

- Tipping mechanics
- Self limiting bracket
- Horizontal loading
- No undesirable couples
- More precise finish
- Colors

## **TIP EDGE ADVANTAGES**

- Automatic progression from tip to translation
- Vertical slot/auxillary use
- Predetermined, full power uprighting
- Fewer archwires
- Torque options

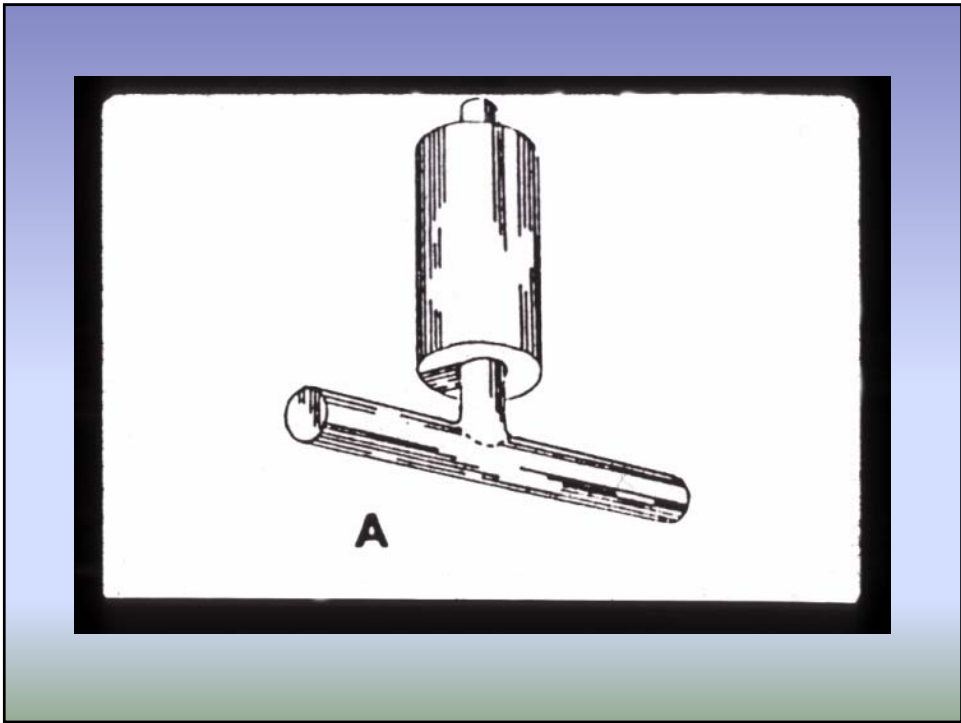
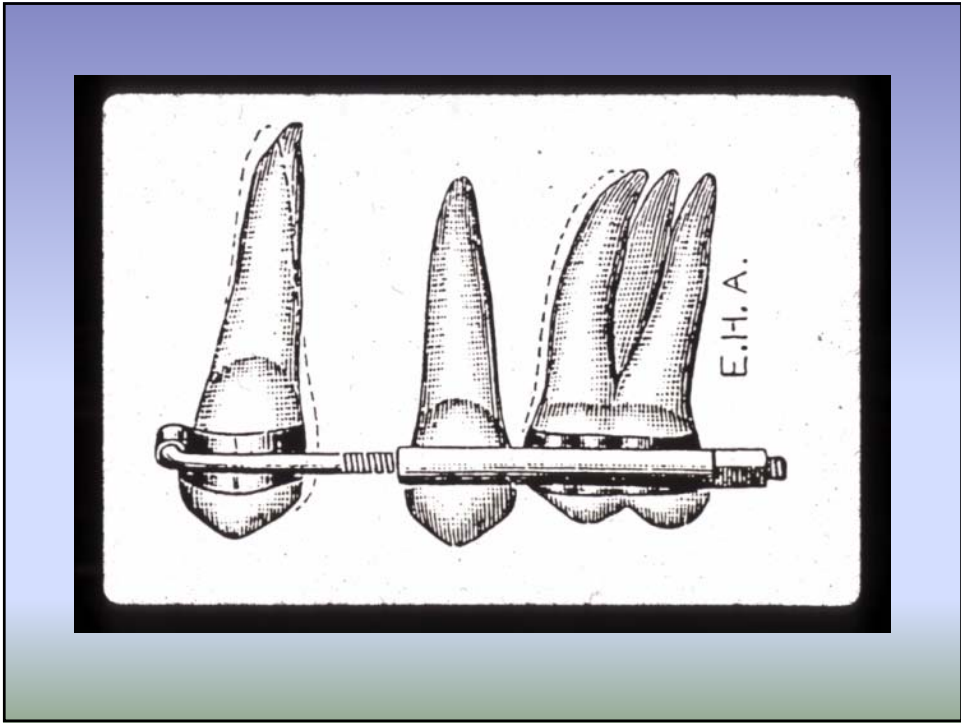

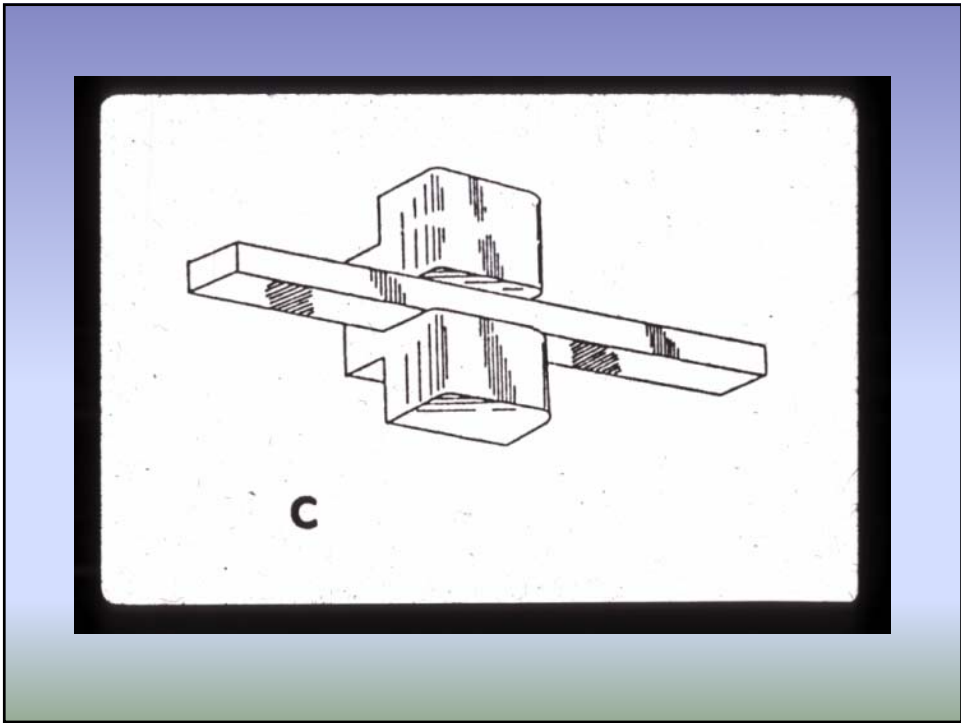
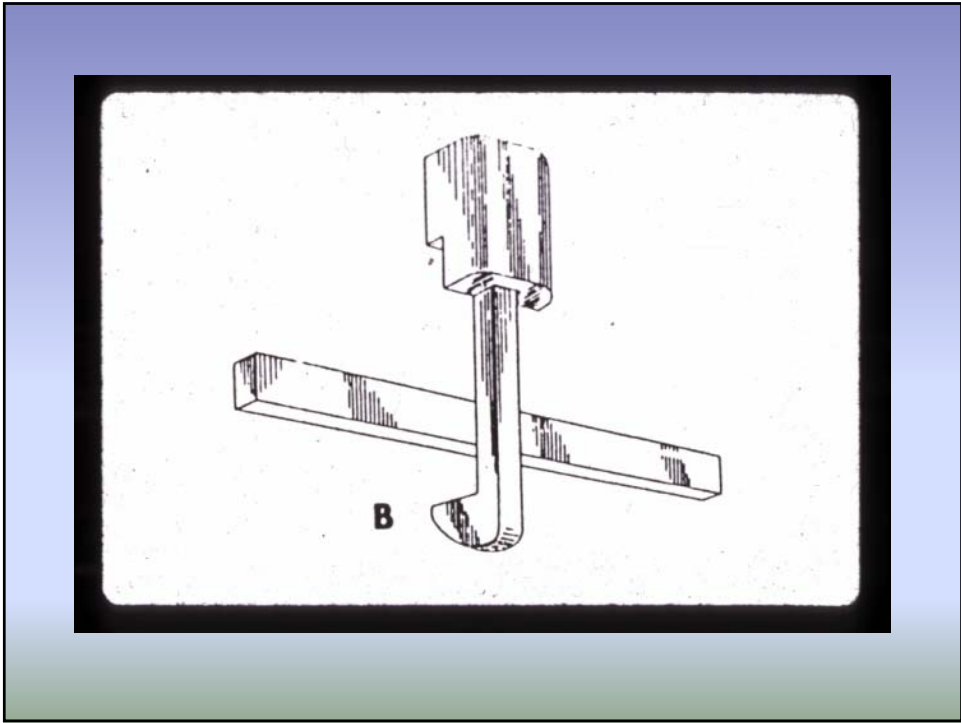

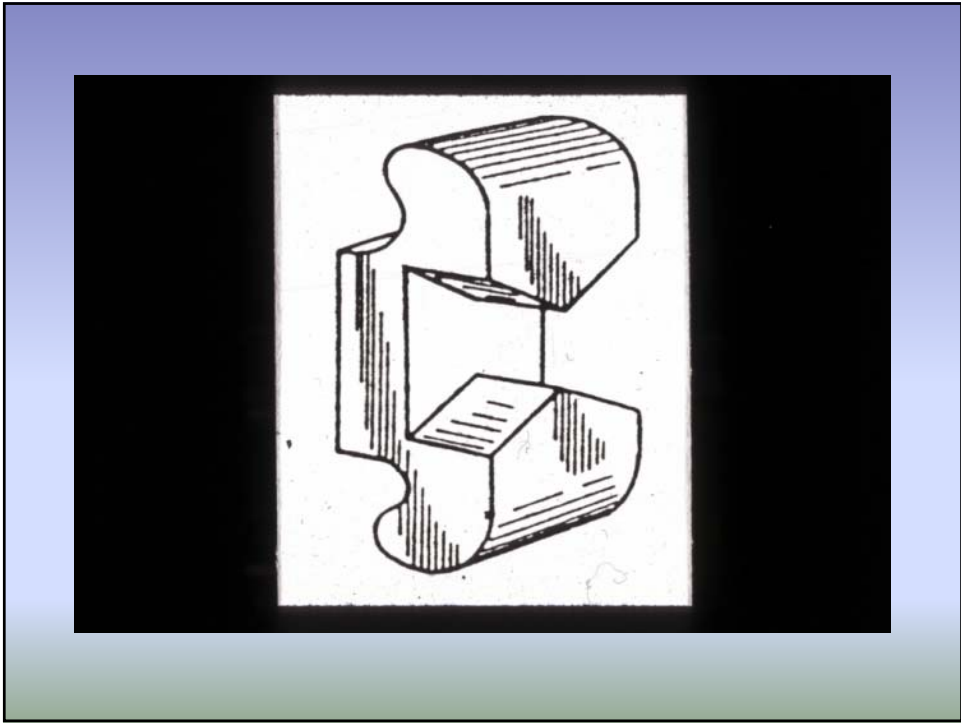

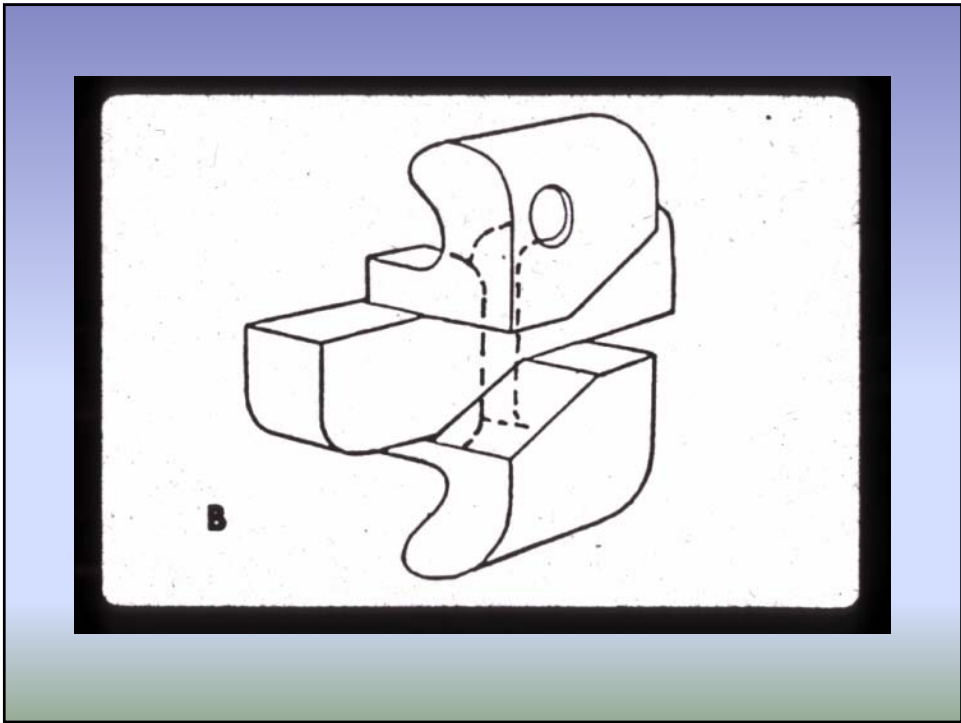
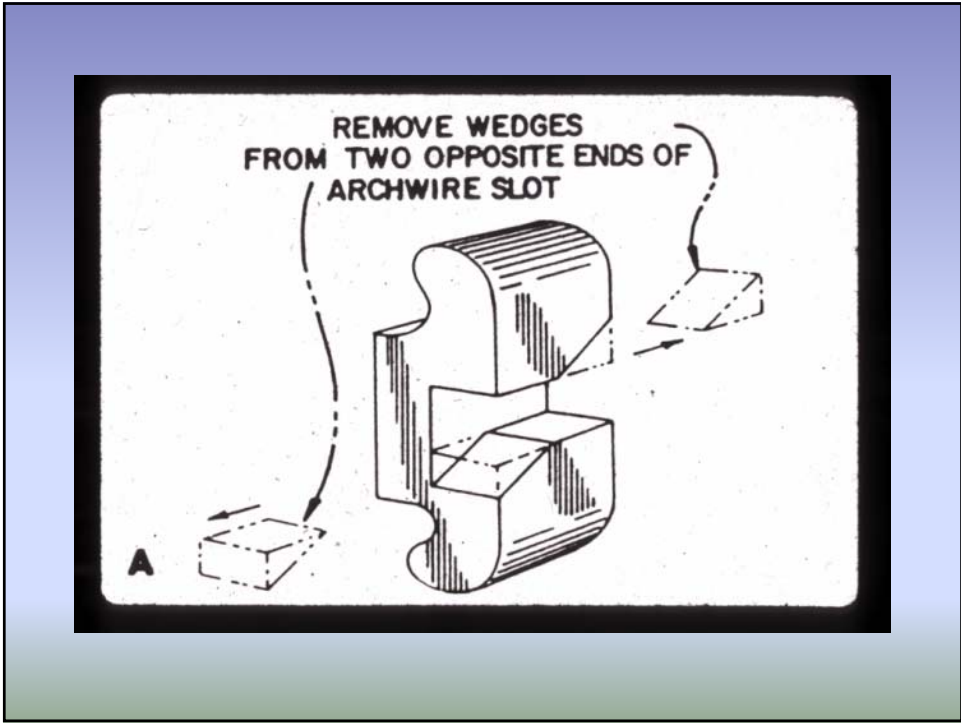

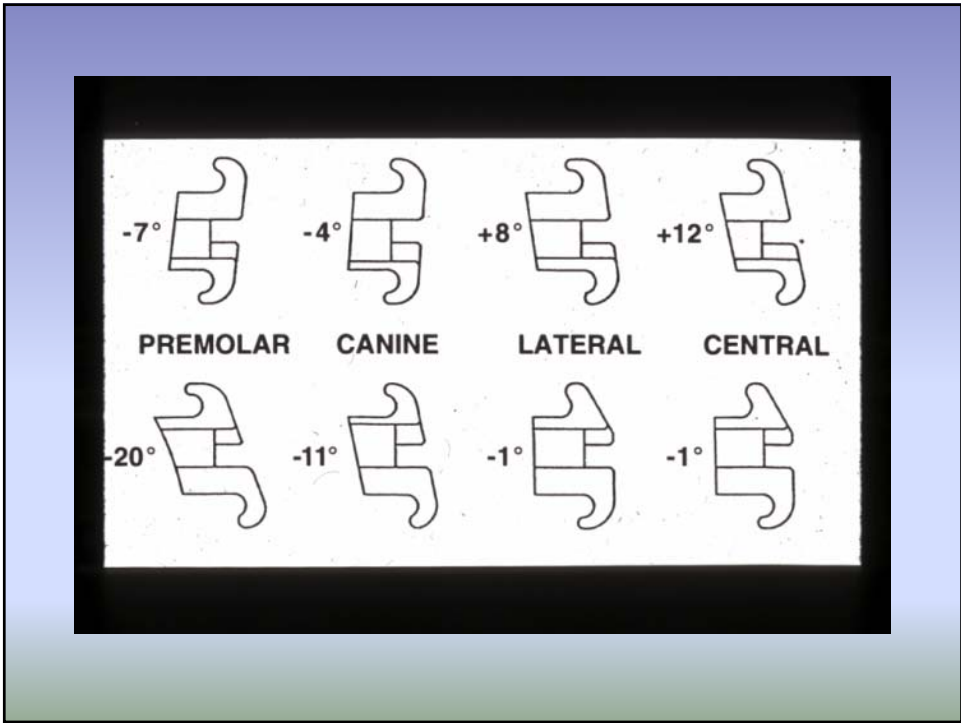
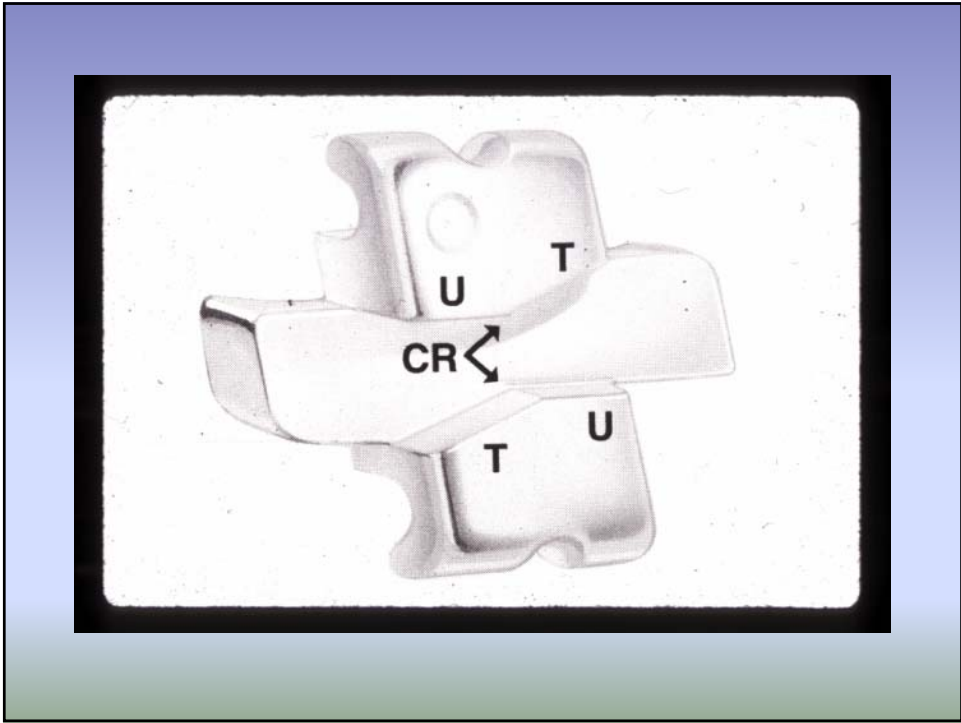

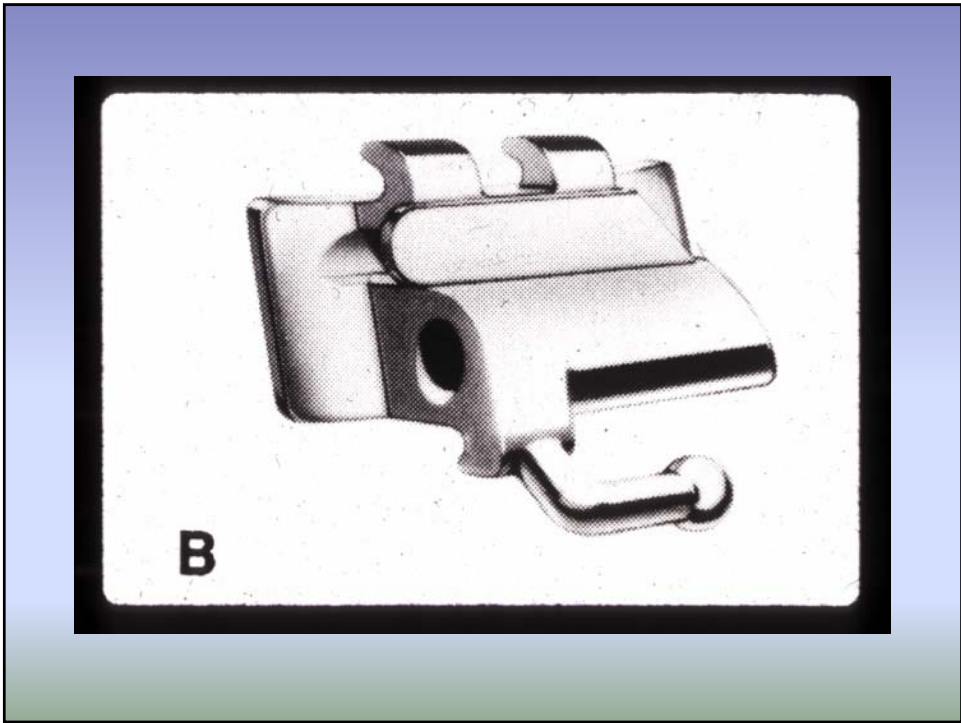
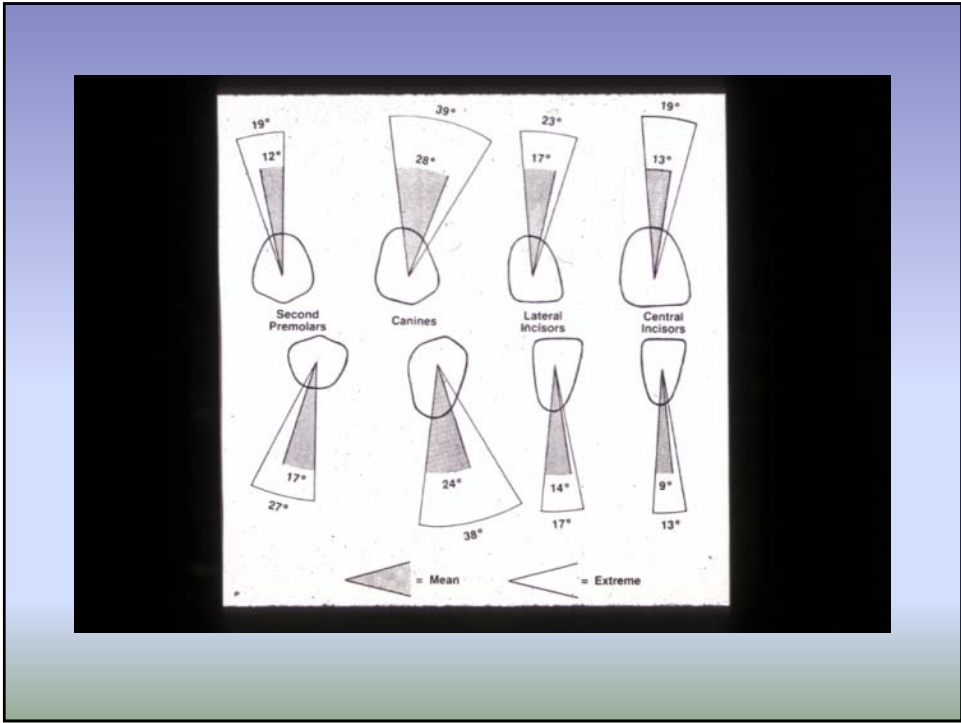

## BRACKET DESIGN

- Initial tip limited
- Torque built into base
- Final tip built into bracket face
- Over torque only possible with round wires

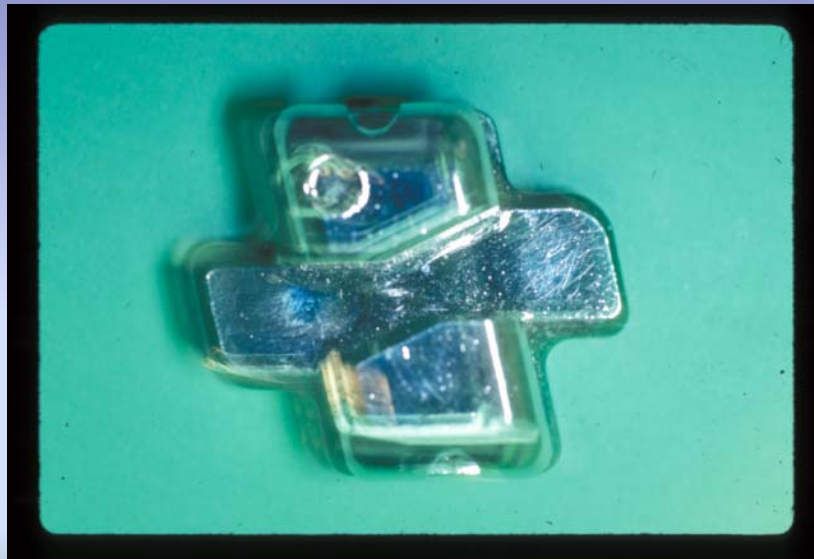

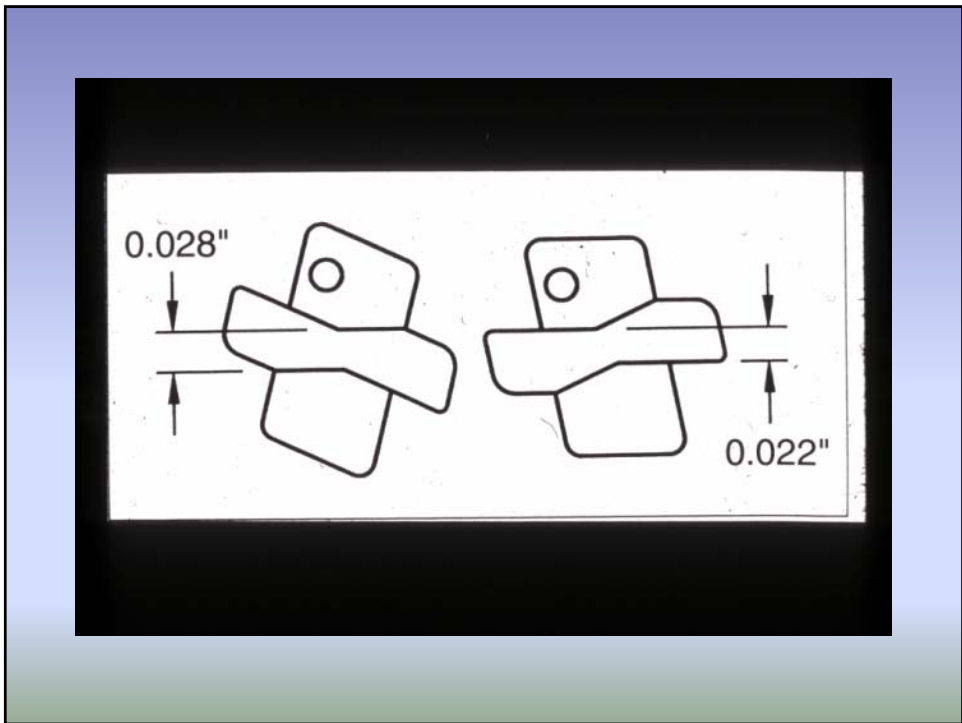
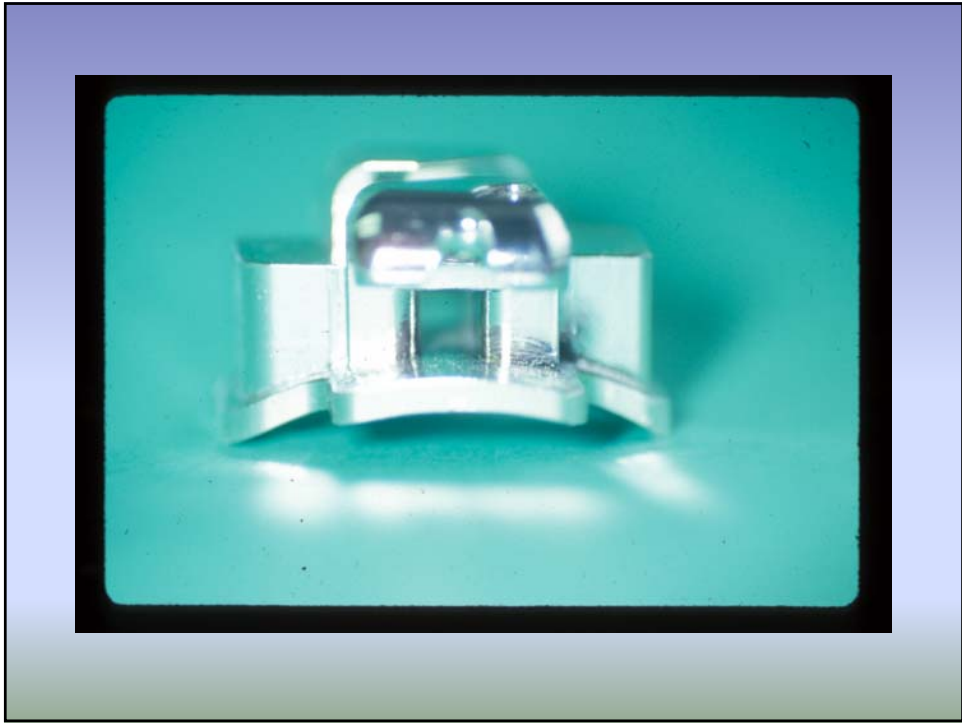









## PATIENT LR

SNA	77
SNB	74
ANB	3
SN GoGn	40
PP GoGn	31
L1 Apo	8.5
L1 GoGn	96
U1 SN	117
N: ANS/ANS:ME	.72
Wits	+1

