

MUCOSAL IMMUNITY

Alessandra Pernis

P&S 9-435
X53763
abp1@columbia.edu

- CHALLENGES FACED BY THE MUCOSAL SYSTEM
- SPECIALIZATION OF CELLS INVOLVED IN MUCOSAL IMMUNITY
- ORGANIZATION OF THE MUCOSAL IMMUNE SYSTEM
- CLINICAL IMPLICATIONS

DEFINITIONS

MALT= MUCOSA-ASSOCIATED LYMPHOID TISSUE

MALT is the highly specialized immune system which protects mucosal surfaces. The lymphoid elements associated with different mucosal sites share organizational as well as functional similarities. It is the largest mammalian lymphoid organ system and in an adult it comprises approximately 80% of all lymphocytes.

COMPONENTS OF THE MUCOSA-ASSOCIATED LYMPHOID TISSUE

- Gastrointestinal tract (GALT)
- Bronchial Tree (BALT)
- Nasopharyngeal area (NALT)
- Mammary gland
- Salivary and lacrimal glands
- Genitourinary organs
- Inner ear

PEYER'S PATCHES

- ORGANIZED MUCOSAL LYMPHOID FOLLICLES WHICH LACK AFFERENT LYMPHATICS.
- PEYER'S PATCHES ARE FOUND IN THE SMALL INTESTINE.
- FOLLICLES SIMILAR TO PEYER'S PATCHES ARE FOUND IN THE APPENDIX, IN THE REST OF THE GASTROINTESTINAL TRACT AND IN THE RESPIRATORY TRACT.

Anatomy of a Peyer's Patch

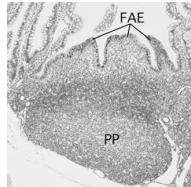

From: Iwatsukit et al., *Histochem. Cell Biol.* 117:1363, 2001

LAMINA PROPRIA LYMPHOCYTES

- LYMPHOCYTES WHICH ARE SCATTERED DIFFUSELY THROUGHOUT THE LAMINA PROPRIA OF THE INTESTINE. (LAMINA PROPRIA=LAYER OF CONNECTIVE TISSUE BETWEEN THE EPITHELIUM AND THE MUSCULARIS MUCOSA)
- LARGEST SINGLE T-CELL SITE IN HUMANS. MOST OF THE T CELLS WITHIN THE LAMINA PROPRIA ARE CD4+.

INTRAEPITHELIAL LYMPHOCYTES (IELs)

- LYMPHOCYTES WHICH ARE SITUATED BETWEEN THE EPITHELIAL CELLS OF THE VARIOUS MUCOUS MEMBRANES.
- THE MAJORITY OF IELs ARE CD8+ T LYMPHOCYTES.

THE CHALLENGES

- MOST FREQUENT PORTAL OF ENTRY FOR HARMFUL SUBSTANCES. THUS THE MALT HAS TO MOUNT AN EFFECTIVE RESPONSE AGAINST A VAST NUMBER OF POTENTIAL PATHOGENS.
- THE MUCOSAL MEMBRANES OF THE DIGESTIVE TRACT MUST ALLOW FOR THE ABSORPTION OF NUTRIENTS BY THE HOST. THUS THE MALT MUST REMAIN HYPORESPONSIVE TO AN ENTIRE ARRAY OF HARMLESS SUBSTANCES.

SPECIALIZED COMPONENTS OF MALT

B CELLS

- HUMORAL RESPONSES ARE CENTRAL TO AN EFFECTIVE MUCOSAL IMMUNITY.
- THE MAIN HUMORAL MEDIATORS OF SPECIFIC MUCOSAL IMMUNITY ARE SECRETORY IgA AND, TO A LESSER EXTENT, SECRETORY IgM.
- THE NORMAL INTESTINAL MUCOSA CONTAINS AT LEAST 20 TIMES MORE IgA+ THAN IgG+ LYMPHOCYTES.

CRITICAL FEATURES OF SECRETORY IgA

- RESISTANCE AGAINST COMMON INTESTINAL PROTEASES
- INABILITY TO INTERACT WITH COMPLEMENT OR CELLS IN A WAY TO CAUSE INFLAMMATION

MECHANISMS OF PROTECTION BY SIgA AT MUCOSAL SURFACES

- INHIBITION OF ADHERENCE
- VIRUS NEUTRALIZATION
- NEUTRALIZATION OF ENZYMES AND TOXINS
- IMMUNE EXCLUSION AND INHIBITION OF ANTIGEN ABSORPTION

FACTORS CONTROLLING IgA ISOTYPE SWITCHING

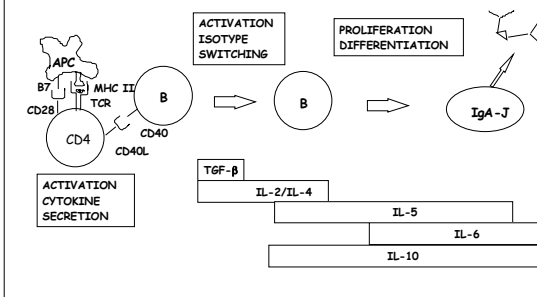

FACTORS CONTROLLING THE SECRETION OF IgA: THE J CHAIN

- THE J CHAIN IS A 15 KD POLYPEPTIDE THAT IS DISULFIDE-BONDED TO THE TAIL-PIECES OF BOTH IgM AND IgA
- IgA SECRETING B CELLS IN THE BONE MARROW DO NOT EXPRESS THE J CHAIN AND THUS SECRETE IgA MONOMERS
- THE MAJORITY OF IgA PRODUCING B CELLS IN THE MUCOSA EXPRESS THE J CHAIN AND THUS PRODUCE DIMERIC IgA
- THE J CHAIN STABILIZES THE MULTIMERS AND IT APPEARS TO DETERMINE THE POLYMERIC IgA AND IgM STRUCTURE WHICH ALLOWS POLYMERIC Igs TO COMPLEX WITH THE SECRETORY COMPONENT

FACTORS CONTROLLING THE SECRETION OF IgA: THE SECRETORY PIECE (POLYMERIC Ig RECEPTOR)

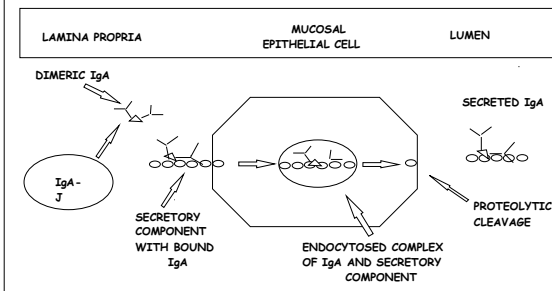

T CELLS

TH1 OR TH2?

MUCOSAL TISSUES	% CD3+	TCR		%CD4+	TH1:TH2	CD4:CD8
		$\alpha\beta$	$\gamma\delta$			
INDUCTIVE SITES PEYER'S PATCHES	25-35	>90	1-5	60	1:1	2:1
EFFECTOR SITES						
LAMINA PROPRIA	40-60	>95	1-5	60	1:2-3	2:1
INTRAEPITHELIUM	80-90	35-45	45-65	5-10	1:1	1:7-8

CHARACTERISTICS OF INTRAEPITHELIAL LYMPHOCYTES (IELs)

- IELs ARE LYMPHOCYTES WHICH ARE INTERSPERSED BETWEEN THE COLUMNAR EPITHELIAL CELLS OF THE VILLI IN THE SMALL AND LARGE INTESTINE
- IN HUMANS, MOST OF THE IELs ARE CD8+ T CELLS. APPROXIMATELY 10% OF IELs ARE $\gamma\delta$ CELLS
- BOTH THE $\gamma\delta$ AND THE $\alpha\beta$ TCR+ IELs SHOW LIMITED DIVERSITY OF T CELL
- IELs EXPRESS A NOVEL INTEGRIN TERMED HML-1 (human mucosal antigen 1).

FUNCTIONAL PROPERTIES OF IELs.

- FIRST IMMUNE CELL LINE OF DEFENSE IN THE INTESTINE
- DISPLAY CYTOTOXIC ACTIVITY
- SECRETE LARGE AMOUNTS OF CYTOKINES ESPECIALLY IFN- γ AND TNF- α
- MODULATE THE KINETICS OF EPITHELIAL CELL RENEWAL
- PLAY A REGULATORY ROLE IN TOLERANCE TO DIETARY ANTIGENS

ORAL TOLERANCE

- ORAL ADMINISTRATION OF A PROTEIN ANTIGEN MAY LEAD TO SUPPRESSION OF SYSTEMIC HUMORAL AND CELL-MEDIATED IMMUNE RESPONSES TO IMMUNIZATION WITH THE SAME ANTIGEN.
- POSSIBLE MECHANISMS:
 - INDUCTION OF ANERGY OF ANTIGEN-SPECIFIC T CELLS
 - CLONAL DELETION OF ANTIGEN-SPECIFIC T CELLS
 - SELECTIVE EXPANSION OF CELLS PRODUCING IMMUNOSUPPRESSIVE CYTOKINES (IL-4, IL-10, TGF- β)

REGULATORY T CELLS (CD4+)

- **TH3 CELLS:** A POPULATION OF CD4+T CELLS THAT PRODUCE TGF- β . ISOLATED FROM MICE FED LOW DOSE OF ANTIGEN FOR TOLERANCE INDUCTION
- **TR1 CELLS:** A POPULATION OF CD4+T CELLS THAT PRODUCE IL-10. CAN PRODUCE SUPPRESSION OF EXPERIMENTAL COLITIS IN MICE
- **CD4+CD25+ REGULATORY T CELLS:** A POPULATION OF CD4+T CELLS THAT CAN PREVENT AUTOACTIVITY IN VIVO.

REGULATORY T CELLS

- **CD8+SUPPRESSOR T CELLS:** THE FIRST IDENTIFIED POPULATION OF REGULATORY T CELLS THOUGHT TO BE INVOLVED IN ORAL TOLERANCE. THEIR FUNCTIONS AND CHARACTERISTIC HAVE NOT BEEN CLEARLY DEFINED
- **$\gamma\delta$ T CELLS:** STUDIES IN MICE INDICATE THAT THEY HAVE AN IMPORTANT ROLE IN SOME MODELS OF ORAL TOLERANCE.

ORAL TOLERANCE

- REGULATING FACTORS:
 - ➔ DOSE OF ANTIGEN
 - ➔ FORM/NATURE OF ANTIGEN
 - ➔ ANTIGEN-PRESENTING CELLS
 - ➔ CYTOKINE MILIEU
 - ➔ ADJUVANTS
 - ➔ LUMINAL FACTORS
 - ➔ AGE

EPITHELIAL CELLS

CHARACTERISTICS OF M CELLS

- M ("membrane-like") CELLS ARE SPECIALIZED EPITHELIAL CELLS WHICH OVERLIE LYMPHOID FOLLICLES DOMES ALONG THE LENGTH OF THE SMALL AND LARGE INTESTINE.
- STRUCTURAL FEATURES INCLUDE:
 - FEW SHORT IRREGULAR MICROVILLI
 - ABUNDANT ENDOCYTIC VESICLES
 - LOW LYSOSOMAL CONTENT
 - DISTINCTIVE GLYCOCALIX
 - BINDING SITES FOR SECRETORY IgA BUT NO SC
 - POCKETS IN THE BASOLATERAL SURFACE

M CELLS

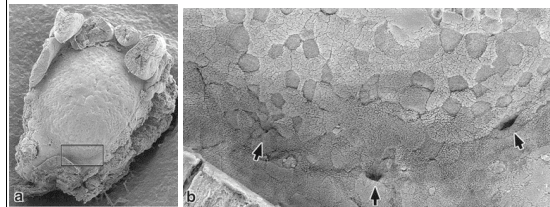

Scanning electron microscopy of a single microdissected dome (a) of a murine Peyer's patch. The M cells are identified by their relatively short, dark brush border; they are restricted to the dome epithelium (upper half in b). Crypts (arrows) are opening to the cleft between the dome and the neighboring villi.

From: Gebert et al., *Am. J. Pathol.* 154:1573, 1999

FUNCTIONS OF M CELLS

- ANTIGEN SAMPLING
- PORTAL OF ENTRY FOR SELECTED PATHOGENS

ORGANIZATION OF MALT

INDUCTIVE LYMPHOEPITHELIAL TISSUES: PEYER'S PATCHES

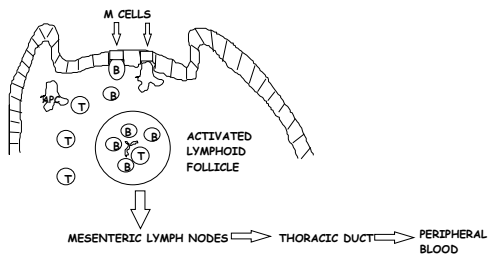

EFFECTOR SITES: LAMINA PROPRIA AND INTRAEPITHELIUM

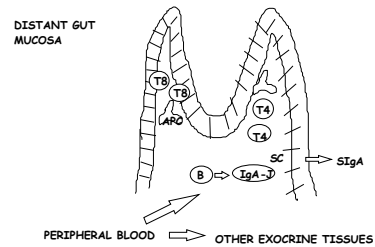

CLINICAL IMPLICATIONS

IgA DEFICIENCY

- IT IS THE MOST COMMON PRIMARY IMMUNODEFICIENCY
- IT IS USUALLY DEFINED BY A SERUM IgA CONCENTRATION OF LESS THAN 50 µg/ml
- IgA DEFICIENT INDIVIDUALS OFTEN APPEAR PERFECTLY HEALTHY AND ARE IDENTIFIED
 - UPON SERVING AS BLOOD DONORS
 - UPON UNDERGOING ANAPHYLACTIC SHOCK WHEN RECEIVING BLOOD TRANSFUSIONS

CLINICAL MANIFESTATIONS OF IgA DEFICIENCY

- INCREASED INCIDENCE OF INFECTIONS
 - UPPER AND LOWER RESPIRATORY TRACT
 - GASTROINTESTINAL
- HIGHER INCIDENCE OF AUTOIMMUNE DISEASES
- HIGHER INCIDENCE OF ALLERGIC DISEASES
- HIGHER INCIDENCE OF CELIAC DISEASE

INFLAMMATORY BOWEL DISEASE (IBD)

- IBD IS A CHRONIC, RELAPSING AND REMITTING INFLAMMATORY CONDITION
- TWO OVERLAPPING PHENOTYPES:
 - ➔ CROHN'S DISEASE (CD), WHICH AFFECTS THE DISTAL SMALL INTESTINE AS WELL AS THE COLON IN A TRANSMURAL MANNER
 - ➔ ULCERATIVE COLITIS (UC), WHICH PREDOMINANTLY AFFECTS THE COLON IN A SUPERFICIAL MANNER
- THE ETIOLOGY IS UNKNOWN: ? DUE TO A DYSREGULATED MUCOSAL IMMUNE RESPONSE TO UNKNOWN ANTIGENS PRESENT IN THE NORMAL, INDIGENOUS BACTERIAL FLORA
 - MUTATIONS IN NOD2 (A CYTOSOLIC RECEPTOR FOR PATHOGENIC BACTERIAL SIGNALS) INCREASE THE RISK OF CD BY A FACTOR OF 20-40.

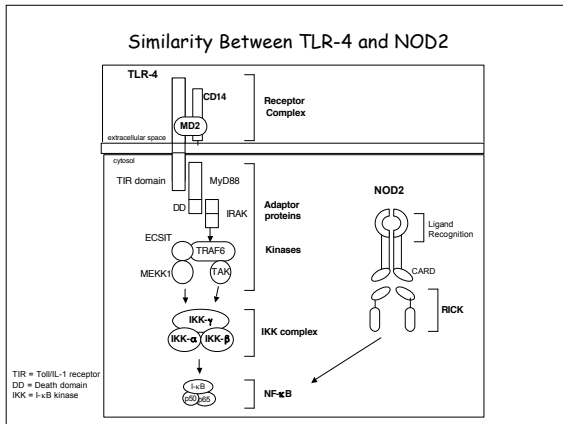

- IBD: IMMUNOLOGIC FEATURES**
- **CELL-MEDIATED IMMUNITY (ACTIVE CD):**
 - ➔ INCREASED NUMBER OF ACTIVATED MUCOSAL T CELLS SECRETING IFN-γ (TH1)
 - ➔ INCREASED MUCOSAL PRODUCTION OF CYTOKINES THAT ACTIVATE TH1 CELLS (IL-12 AND IL-18)
 - ➔ DEFECTS IN REGULATORY (IL-10 PRODUCING) T CELLS

- IBD: IMMUNOLOGIC FEATURES**
- **HUMORAL IMMUNITY: MASSIVE INCREASE IN THE NUMBER OF PLASMA CELLS AND IN IgG PRODUCTION (IgG2 IN CD AND IgG1 IN UC)**
 - **IMBALANCE OF PRO-INFLAMMATORY (TNF-α, IL-1, IL-8, IL-12) AND ANTI-INFLAMMATORY CYTOKINES (IL-10, IL-4, IL-13)**

- IBD: EMERGING BIOLOGIC THERAPIES**
- **INHIBITORS OF PROINFLAMMATORY CYTOKINES**
 - Anti-TNF therapies: infliximab
 - **ANTIINFLAMMATORY CYTOKINES**
 - IL-10
 - IL-11
 - **ANTI-LEUKOCYTE ADHESION THERAPIES**
 - Anti-α4 integrin: Natalizumab
 - **INHIBITORS OF TH1 POLARIZATION**
 - Anti-IL-12
 - Anti-IL-18
 - Anti-IFN-γ

- CELIAC DISEASE**
- **CELIAC DISEASE IS A T CELL MEDIATED IMMUNE DISEASE OF THE SMALL INTESTINE TRIGGERED BY GLUTEN**
 - **MAJOR FEATURES:**
 - ➔ VILLOUS ATROPHY WITH A LYMPHOCYTIC INFILTRATE
 - ➔ INCREASED EPITHELIAL PROLIFERATION WITH CRYPT HYPERPLASIA
 - ➔ MALABSORPTION

- CELIAC DISEASE: IMMUNOLOGIC FEATURES**
- **ANTIGEN: GLUTEN (gliadin and glutenins)**
 - **IT IS ASSOCIATED WITH HLA-DQ2 OR HLA-DQ8 RESTRICTED LAMINA PROPRIA CD4+ T CELLS THAT RECOGNIZE GLUTEN AND SECRETE INTERFERON γ (98% OF PEOPLE WILL CARRY THESE HAPLOTYPES)**
 - **GLIADIN IS A SUBSTRATE OF TISSUE TRANSGLUTAMINASE (TRANSFORMS POSITIVELY CHARGED GLUTAMINES TO NEGATIVELY CHARGED GLUTAMIC ACID)**
 - **INCREASED B CELL ACTIVITY**
 - ANTIBODIES AGAINST GLIADIN (IgA-AGA, IgG-AGA)
 - ENDOMYSIAL ANTIBODY (IgA-EMA)
 - TISSUE TRANSGLUTAMINASE (IgA-tTG)

CELIAC DISEASE: IMMUNOLOGIC FEATURES

- IMPORTANTLY THE HALLMARK OF CELIAC DISEASE IS INTRAEPIHELIAL INFILTRATION BY CD8+ T CELLS
 - DIFFERENT FROM IBD
 - IELs ARE BELIEVED TO PARTICIPATE IN THE PATHOGENESIS OF CELIAC DISEASE BY MEDIATING THE DESTRUCTION OF THE EPITHELIUM
 - RECENT EVIDENCE POINTS TO THE FOLLOWING SCENARIO:
 - GLUTEN ALTERS EPITHELIAL CELLS OF PATIENTS WITH CELIAC DISEASE LEADING TO PRODUCTION OF IL-15 AND TO THE EXPRESSION OF NON-CLASSICAL MHC CLASS I MOLECULES. IL-15 IN TURN LEADS TO THE EXPRESSION OF RECEPTORS ON IELs FOR THESE NON-CLASSICAL MHC MOLECULES AND TO THE ACTIVATION OF THE IELs, WHICH THEN KILL THE EPITHELIAL CELL

MUCOSAL IMMUNIZATION

MUCOSAL VACCINES

- VACCINES AGAINST MUCOSAL INFECTIONS MUST STIMULATE THE MALT IN ORDER TO BE EFFICACIOUS
- BECAUSE OF SUBCOMPARTMENTALIZATION WITHIN THE MALT, VACCINES MUST BE ADMINISTERED BY THE APPROPRIATE ROUTE
- NONREPLICATING ANTIGENS ARE OFTEN RELATIVELY INEFFICIENT IN YIELDING STRONG AND LONG-LASTING MUCOSAL ANTIBODY RESPONSES

MUCOSAL VACCINES

- NEW STRATEGIES FOR ANTIGEN DELIVERY:
 - ➔ LIVE ATTENUATED RECOMBINANT BACTERIA AND VIRUSES WITH KNOWN MUCOSAL TROPISM
 - ➔ PROTECTIVE VEHICLES, E.G. LIPOSOMES AND BIODEGRADABLE MICROSPHERES
 - ➔ MUCOSAL LECTIN-LIKE MOLECULES ENDOWED WITH IMMUNOSTIMULATORY PROPERTIES, E.G. CHOLERA TOXIN

MUCOSAL IMMUNOTHERAPY

- STRATEGY TO ATTEMPT TO TREAT ILLNESSES RESULTING FROM IMMUNE REACTIONS AGAINST AUTOANTIGENS ENCOUNTERED IN NONMUCOSAL TISSUES
- HUMAN TRIALS HAVE BEEN CONDUCTED IN MULTIPLE SCLEROSIS, RHEUMATOID ARTHRITIS, UVEORETINITIS, AND TYPE I DIABETES

MUCOSAL IMMUNOTHERAPY

- POTENTIAL PROBLEMS:
 - ➔ LIMITED SUCCESS IN SUPPRESSING THE EXPRESSION OF AN ALREADY ESTABLISHED IMMUNE RESPONSE
 - ➔ MASSIVE AMOUNTS OF TOLERogens ARE REQUIRED
 - ➔ IMMUNOSUPPRESSIVE EFFECT IS OF SHORT DURATION