

The Birthday Party: An Experiment in Obtaining Change in One's Own Extended Family*

RABBI EDWIN H. FRIEDMAN†

The author describes a venture in providing disequilibrating information and experience to his extended family with a view to inducing change in stable patterns of interaction. The philosophy and method derives from the teachings of Murray Bowen.

It is thought by many that anyone who engages in the practice of individual therapy would benefit, both personally and in his work, from experiencing such therapy. Can the same be said for those who practice family therapy? My guess is that, in fact, many who practice family therapy with their patients are often tempted to use their skills and insights to try to obtain change in their own families. Perhaps the family therapist may be said to be in a perpetual multiple family group as he draws parallels and refers insights back and forth between relationships in his own family and those in the families with which he works.

To work therapeutically with one's own family could be the concealed expectation of the family, and a major force in drawing the therapist to that kind of professional work. After all, if patients are to be seen as symptoms of their family networks, why not therapists?

* This paper was delivered in October, 1970, at the Sixth Annual Symposium on Family Therapy sponsored by the Department of Psychiatry at Georgetown University School of Medicine.

† The Family Workshop, Bethesda, Md. 20034.

We talk about *identified patients*, why not talk about *identified therapists*? I shall come back to this idea more explicitly later.

This essay will describe a studied, carefully planned attempt to obtain change in my own extended family over a two-year period, the focal point or fulcrum for the whole process being a surprise birthday party for my mother on the occasion of her seventieth birthday. The work was done in consultation with Dr. Murray Bowen under whose supervision I received my general training in working with families.

The format of this paper will be as follows: first, a brief description of the extended network in which I wished to see change occur, pinpointing those areas where I felt dysfunctional symptoms of the network could be identified; second, a description of the way I tried to encourage the process of change with some exposition of the theory on which I based my own actions; and third, some after-thoughts and general conclusions about how the professional person may work within his own extended family to obtain change.

Figure I describes my extended family on my mother's side. My mother is represented by the circle which occupies the next to the last position in the third generation (containing the number 70); my own position is represented by the square containing the letter "E." The diagram represents five generations, though only the third and fourth (with one exception) are relevant to the experiment carried out. As the reader can see, the first generation had three children, two girls and a boy. They were born in Europe and came to America where they produced fourteen offspring (all first generation Americans). The sisters each had five children, the brother had four. My mother's generation of fourteen cousins, on the other hand, produced only twelve

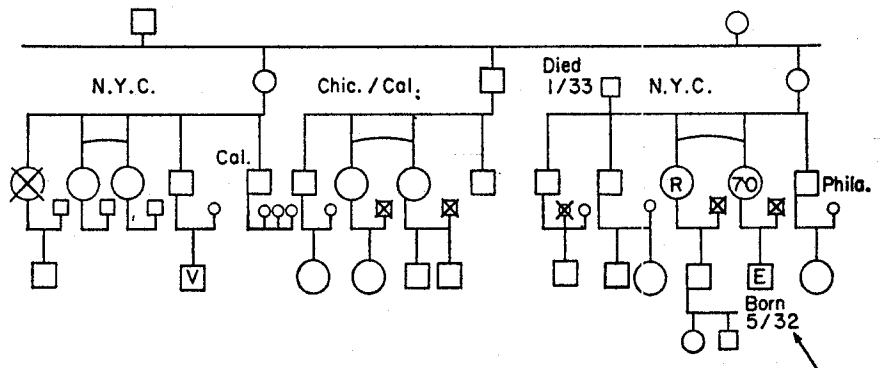

FIGURE 1.

offspring, primarily in multiples of one! Four of my mother's cousins had no children (one never married), and only two of the remaining had more than one child. In each case, the two cousins who were the only members of their generation to have more than one child were the siblings who became most involved in their spouse's extended family—that is, they were most out of the system.

Some other interesting attributes of the system are these: every one of my mother's first cousins at the time of the party (July 1968) was alive and in his seventies except for her younger brother who was sixty-eight, and the woman who had been the oldest. She had committed suicide twenty-five years previously. Secondly, in each of the three sets of siblings that made up my mother's generation, the sisters had stuck together. My mother and her older sister (R) live on the same floor of the same apartment house in New York City. The two sisters in the Chicago group live in the same apartment. All four are widows, having lost their husbands around the age of fifty-five to sixty. None remarried. My mother and aunt, however, have had almost no contact with the Chicago cousins and never met the younger one. The other two sisters from the group on the left have lived within walking distance of one another on the northern tip of Manhattan throughout their entire lives. They have never had children, and they have never become widows!

It should be noted also that in the middle set of my mother's cousins, the two boys have always lived together, the youngest of that set living with his married brother in California. In contra-distinction to this pairing off among siblings in my mother's generation, their children live almost totally separate lives from one another. It is true that they are cousins and not siblings, but generally speaking it can be said that the cousins on my level are almost never in communication with one another.

There were three points in the network where I wished to see change; that is, where I felt pathological symptoms of the network were showing up. One was my own relationship with my mother which I felt was distant and rigid despite many efforts on my part to be closer to her. Second concerned my next oldest cousin's son (the male member of the fifth generation indicated on the chart) who started taking drugs at thirteen, was obese and doing poorly in school, in contrast to his older sister, who was bright, witty and charming. The third place I wanted to see change was with regard to the younger of the

two New York City cousins (V), who, despite the fact he was an extremely successful professional person, was nearing forty and was unmarried, indeed the only unmarried member of my generation.

At the time of writing this paper, two years and three months after the party, not only has my relationship with my mother changed considerably but my younger cousin has just been enrolled as a freshman at George Washington University and allowed to take honors courses his first year, and my older cousin has been married for more than six months.

The Process

Since my own work with families is at the systems end of the continuum rather than the analytic, I should like to begin this section by indicating my conceptual approach to family systems. By *system* I mean a set of relationships which, upon achieving homeostasis, functions to maintain that homeostasis through inner-adjusting compensations. Change in one relationship of a system so defined will usually bring about change in another relationship.

When it comes to family systems, I do not equate the degree of physical distance with the degree of emotional distance. People certainly are involved in important non-family relationship systems, but I think those other systems are rarely as intense emotionally as the family system so that a family relationship that is physically distant can be much more influential than a non-family relationship of greater physical proximity. The potential for becoming free from the influence of one's family system, however, is much greater in an approach that brings one towards the family than in an approach that takes one away. I think, therefore, in terms of differentiation of self *within* the system rather than independence of it, and do not believe it is really possible to become independent of one's family system except by becoming intensely part of another system (and then all one has succeeded in doing is transferring the dependency).

Success at achieving such differentiation of self can be measured, I believe, in the extent to which one can be a part of the family without automatically being one of the "emotional dominoes." The path towards such a goal can be achieved best not by a process of internal analysis of oneself but through a process of external perceptions that analyze the system. In other words, I do not think in terms of a *sense* of self, which seems too unverifiable, but in terms of a *position* of self.

decided that the biggest "no-no" in the family—perhaps because no one was dying—was age; I took note of my own relative disengagement; I noticed also that I was almost the only member of my family with a "helpful" title.

In these terms the question was, what would be the most "unthinkable" event one could carry out in this family system. Obviously, to give a birthday party—indeed a surprise birthday party—a ball for Cinderella, so to speak, outside of New York City, and given by the last person the family might have expected to throw a ball.

For three months, therefore, I set about calling every one of my mother's cousins and siblings—from the top down, in deference to age. Her sister, as you can imagine, was against it—until I put her in charge of something. Added and unexpected benefits came during this phase, as in conversation with each relative I had to ask information about the others, received the information in the form of opinions I did not expect but made sure to pass on to the others when I called them. It was as though there were little light bulbs connected into each circle and square on the genogram that were either all out or all on (steady state sort of thing); the day I started telephoning those bulbs started flashing—out of phase—for the first time in many, many years. Something dormant (and apparently dead) came to life.

One interesting detail during this part of the process may be mentioned. When I called the oldest group of cousins, living in Manhattan, the brother said they couldn't come because one of his sisters was very, very sick but he would tell his sisters for me and I needn't call. I called the sister who wasn't sick and she said she couldn't come because her sister was very, very sick, and she would tell her for me; I needn't call her sister. Now remember it was the brother's son who was unmarried. When I spoke to the sick one, I found her much brighter and much more knowledgeable about the family than the other two—this certainly fit all my ideas about families, namely that it couldn't be clear at all who was sick for whom, that indeed the symptomatic one was often the most aware and responsible one. So I wrote her a short note saying I was sorry they all couldn't come down for the day and I realized that she had a responsibility to keep the family together, but how would we ever get Vicky (my unmarried cousin) married. As I calculate, that letter arrived in New York on a Friday and the following Monday Vicky called to accept the invitation and asked if he could bring a girl.

With the exception of Vicky none of my mother's cousins was able

to come nor did any of her close friends whom I called—all, however, kept the secret, and all sent good wishes. To each person I had sent a list of the names of everyone invited. There were twenty-six people at the party, and the surprise was total. Only one of her siblings did not come, the next oldest brother. He, incidentally, married secretly when young, fifty-five years previously, and came back to live with the family for six months before he announced he was married. He was the only sibling who had two children, the one from this group, as I mentioned before, who was more a part of his spouse's system. I point this out because it has become my experience generally to note with families that brothers and sisters will carry out inter-relational inputs at age seventy as though they were still viewing one another as age seven.

There is one other grouping I should like to mention before talking about the party itself. One of my mother's intimates was not a blood relative but her sister-in-law on my father's side; that is, my father's brother's wife. My aunt and uncle had lived in Canada with their only child, a son, for forty years, had been extremely successful in the retail business and were perhaps my nuclear family's closest relatives second to my mother's sister's family. In recent years this aunt had been sickly, alcoholic, depressed, and had growths on her feet that necessitated repeated operations. At any given time, however, she was liable to recover completely from everything and take a trip half way around the world. When my father died, this aunt and uncle had begged my mother to move to Canada to be near them.

This group also would not come to the party because my aunt had become phobic after she finally stopped drinking. And like the group on Northern Manhattan none dared fly away for a day "to the heat of Washington." I learned as much about those who did not come to the party as those who did. For example, the absurd excuses given by this group and the one on Northern Manhattan made their own stuck-togetherness stand out in relief and pointed out directions for follow-up in the future.

The party itself was a complete success, especially considering the logistics. People came from four cities and had to meet at one place at precisely the right hour while my mother was bluffed into going out for an hour. The caterer was precision itself, arriving and setting everything up during that same time. Actually, I felt the success at keeping the secret, that is, the ease with which I was able to get my family to gang up in a conspiracy against my mother did not speak well for my

family. Her total surprise, however, confirmed my feeling that I had done something truly unthinkable.

At the party one event in particular was significant. My next older cousin, my mother's sister's son, had been like a complementary sibling to me. Although Walter Toman in his work on sibling constellations recognizes the complementary aspects of sibling relationships, he says only children are "wild cards." It has been my experience generally that if there is enough feedback between their parents, two only children from the same family will produce some kind of complementary system. My cousin is an accountant, very proper in all ways, no maverick opinions, and super-responsible for our two mothers. He became totally, helplessly drunk within one hour after the party started and was walked around outside by his wife for the next three hours. During this time, his son, whom I knew only to be obese and failing in school, told me he had been on hard drugs for the last two years. In the middle of the party when I investigated a strange tinkle of breaking glass downstairs, I found my aunt, seventy-one, who in her concern for her son, had given our glass sliding door something that must have been a karate chop with her knee as she went to look for him. She was uninjured but the entire door had been shattered. Rushing in to keep the party going, I told everyone upstairs that they would never guess what my Aunt Rose had done to upstage my mother, her younger sister. Strangely, maybe because of the way I put it, nobody believed me, and everyone went right on eating and drinking while my unmarried cousin, the dentist, applied iodine.

In the months that followed the party, the following events occurred in rather rapid succession: one month later my conservative cousin had grown a beard; for my aunt, who will clean an ash tray before you have finished your cigarette, this was truly earth-shaking. I wrote him a letter telling him I thought it was a terrible thing to do to his mother and whom would I look up to now? I also wrote my young cousin a letter asking him seriously what his trips were like and received a long exposition about the effects of LSD on *coitus*—to use his word. He also announced that he had given up drugs because he wanted whole children. Two months later my mother's younger brother, the youngest in this line of cousins, the only one who was not seventy, dropped dead of a heart attack. His wife thereupon came to Washington six months later to live with her married daughter and, as previously noted, the younger cousin enrolled at George Washington University the following year. Precisely between those events my

dentist cousin married a Gentile divorcee with two children—the granddaughter of a prominent New York Protestant clergyman. They were to come to Washington for a private marriage ceremony by me, but his father had a heart attack, and they haven't made it yet.

During the following year my Canadian aunt made an unsuccessful suicide attempt with drugs. I wrote this aunt a letter, having been told by my uncle and cousin that she couldn't come to the phone. In the letter, I told her that I had always thought of her as my most competent aunt, considering her success in business over the years, and I couldn't understand how she would do such a sloppy job of committing suicide. I followed those lines describing my own life in the most depressing terms I could think of. As I say, I was encouraged to do this by what I had seen with the other group. The reaction of my aunt was most interesting.

As it turned out, my mother arrived in Ottawa two days after the letter. My aunt never revealed the contents, and to this day everyone is saying what a wonderful thing my mother did for my phobic aunt, who had not left the house in two years and was now, "as a result of my mother's visit," back to her old self. Indeed she has since struck up relationships with other relatives in the States and relates to me entirely differently than to anyone else. (It never ceases to amaze me that those who think of "systems" as a "cold" approach usually resort to electrical means when it comes to shock.) My aunt has re-established contacts with her own family of origin from which she had become increasingly cut off over the years. I paid a visit to her during the summer two months later, during which time she gave me "hell" for writing such a nasty letter; she came down to Washington in September to hear me preach (for the first time) during the High Holy days; she went to some weddings on her side of the family the following month. And in December she told my uncle that she could no longer take their forty years of a battling marriage, their separate vacations, etc, and that this time she really was going through with their ten-year-old suspended but constantly threatened separation agreement. My uncle went off to the West Indies for a month and came back with cancer of the liver. He died two months later.

I have, since the party, kept up my own interest in the extended network, paying a trip to Chicago, for example, to visit my mother's and aunt's two girl cousins and wound up in the ridiculous position of having my mother and aunt question me about the family for a change; they had never met the younger one, age seventy-two.

The Hangover

In this last section I should like to describe some of my thoughts and conclusions about doing work in one's own family. I shall subdivide this section into two parts: technical and personal.

From the point of view of technique I would say I consciously tried five different varieties. Listing them in order of *least* effectiveness, I would say they were: 1) being straightforwardly analytic about people or relationships, that is, being the expert; 2) telling them a story about one of my clients; 3) performing verbal reversals; 4) performing behavior reversals, and; 5) being stupid—this one has to follow, if being expert is at the other end of the scale.

Regarding the straightforward analytical approach, I found that the reaction was almost always one of denial. I was told I didn't understand, or a comment would be made about my playing therapist. On the other hand, when I went to Canada after my aunt's suicide attempt and spent one week with the family, never once making an interpretation, I found by the end of the week they got so scared by this that they began to talk to me in a way that showed they knew more, and maybe thought more, in analytic terminology than I did.

Telling them about a client had some limited effectiveness. On several occasions since the party when members of my family were deeply distressed about something, I found that telling them about a similar situation from my practice helped de-personalize the situation for them. It reminded me of what had worked and not worked with the client and thus helped me know how to behave at that moment. But most of all, I think, it enabled the conversation to continue with me in the position of experienced relative who was not trying to change them but who, from their point of view, despite his experience, didn't seem too anxious about it either.

For example, for about a year my mother's older sister had been obsessed with anxiety about gastrointestinal problems. In her concern over the doctor's failure to find something specific, she had not been eating and was thus losing weight. The loss of weight contributed further to her worry that something sinister was at work. Everyone including the family doctor had been at a loss to reassure her. I had treated a similar case with a "paradoxical intention" barrage: did she know where the cancer was, what progress did she think it had been making and, finally, people didn't just get cancer, she must have done something wrong, perhaps God was punishing her.

Thus I dealt with my aunt by: 1) not attempting any re-assurance; 2) figuring, but not mentioning, that it had something to do with her son's involvement elsewhere (which indeed turned out to be the case); and 3) telling her as coldly as possible that I still needed her help in getting my mother straightened out, and I would appreciate it if she could just hang on a bit longer.

The third technique is verbal reversals. The two kinds I have employed most have been to out-kook and to go contrary to my instincts. An example of an out-kooking dialogue might go like this (with my dramatic aunt from Canada and in front of my mother who always feels so sorry for her):

aunt: Eddie, what do you think of me?

me: I never analyze my relatives.

aunt: I have opinions about you.

me: Well, maybe you can get more distance.

aunt: You must have some opinions.

me: Okay, I think you're crazy, but it sure keeps you from being boring.

The other form of the verbal reversal is to follow one's instincts and then do the opposite. Thus when my aunts, who are in their seventies, complain about their sundry ailments, and I find myself thinking "they're old, afraid of dying, lonely, etc," I immediately tell them they're getting older, or nobody lives forever. Sometimes before they get a chance to complain, say on the phone, I tell them they sound terrible. And then we usually have a delightful conversation. As my mother got close to retiring (at seventy-two), I would take her for a drive and point out the new old folks home and describe how secure she would be there. She is now looking for another job and applying for unemployment insurance!

The effect of the verbal reversal on these relationships is, I believe, that I convey I won't play their games. Consequently they relate in a much more adult manner to me than to those who take the so-called compassionate approach. I believe I sometimes set an example for other members of the family and make unthinkable actions do-able.

The fourth technique, the action reversal, is more effective, I believe, though I must admit that this dichotomy between verbal and action reversals is somewhat artificial. There are two kinds here, also. One is to behave in a situation the way no one in the family ever does, the other is to behave the way you yourself never do. The party was

so successful, I believe, because both things happened. I have been doing a lot of research on how widows should invest their money, and sending advice to my mother. My CPA cousin has always done my mother's income tax—for free—and she naturally takes my very professionally-appearing plans to him, who admits to my mother he hasn't done much thinking about this area. My final recommendations are always overly-conservative, and he winds up having to suggest something more speculative in comparison.

Switching means of communication is another good behavior reversal (say phone and letter), but reversing whom one talks to about whom is better. Throughout my life I have had gossipy talks with my mother about my aunts; recently I have been doing this with my aunts about my mother. For example, my mother always took a highly sympathetic and supportive position toward my Canadian aunt despite years of my telling my mother that I thought she was selfish. I got a juicy tidbit from my aunt about how she thought my father secretly liked her and passed it on. My conversations with my mother now are filled with my mother's diatribes about my aunt as I try to explain that you have "to understand her." I find that the more I do this the freer my mother seems to be with me. (My grandfather died six months after I was born, and I believe I replaced him in some original triangle with his two daughters.)

The best reversal I have found, however, is to refuse to be serious about what the family is most uptight about. I would add, however, that being exaggeratedly over-serious sometimes seems to amount to the same thing. (I am also coming to believe there would have been much less possibility that my hypertensive father would have died at 56 if he could have taken my mother's "goodness" less seriously.)

This brings me to the fifth and I believe most powerful way of inducing change in one's family, and primarily I believe because it focuses one most on his own inputs, and that is what I call being stupid. At the beginning of this essay I raised the question if patients were to be considered symptoms of their family system, why not therapists? Maybe the same processes that produce dysfunction create other kinds of functioning. Or, since we are talking about process, if when a member of a family becomes the patient, the other members respond in a way that keeps that person in the patient role even though it is ultimately to their own detriment. Maybe a similar process goes on regarding professionals and their families: that once someone becomes a member of the helping professions the effect on the family is to have

them adapt to that person in ways which are not necessarily helpful to that person or themselves. If this is true then the way to get the most change in the homeostasis of such a system is clearly never to play therapist in the system, that is, therapist as they would think of therapist, indeed to play anti-therapist. (Stirring up trouble, not being helpful or responsible, giving pain or at least not rushing in to relieve it.)

All forms of reversal help in this matter, of course. I asked my formerly alcoholic aunt to take back a bottle of unusual Scotch as a gift to my cousin. She "forgot" it at my mother's in New York. Until my dentist cousin got married I never missed an opportunity to remind him of his responsibility to his aunts and parents as their only offspring. I have found, however, that asking stupid questions or making obvious common sense interpretations of equally obvious pathological behavior turns relatives into very insightful people. And that gets me asking, "Well, if they knew the answers all along why the hell are they asking me about the problem?"

For myself as rabbi another way I have found to be unprofessional is to fail to go, no less to perform, weddings and funerals for members of the family. This is producing a very strong reaction: on the other hand you can almost watch the shifts in responsibility among my cousins when I force my family members to find their own rabbis. For example, when I just couldn't make it to an uncle's funeral, another cousin (the oldest in the line) who went, took charge. This has changed his relationship with that uncle's family and I believe had corresponding salutary effects on his own nuclear family.

I find this quite a paradox: that is, by *not* helping precisely where because of my professional expertise I could have been most helpful, I *may* have been more useful.

Now I should like to conclude with a few personal observations. This whole paper has been framed in terms of obtaining change in one's extended family. Yet I am quite sure that the person benefitting most from any attempt to induce such change, at least in the ways I have been describing, is the person doing it. In fact, it would be my guess that if one sets about trying to induce change for the sake of inducing the change, or for the sake of helping the relatives primarily, it won't work, or at least it won't work as well. The paradox here is resolved, I think, by remembering that as long as you are doing it for others you would be behaving as a therapist, a role that is hard to get out of and that secretly maintains homeostasis.

The approach I have been taking, therefore, is to do these things to see what it teaches me about my family. This in turn, however, has raised some interesting and serious theoretical questions. First of all, I have been wondering recently if these five techniques do not wind up with exactly the same effectiveness rating when one is working professionally with families. This is an exciting idea for I have never been comfortable with a style of therapy that could not also be a style of life. Thus, I have begun to ask myself if what I have most in common with those who see me professionally is that we have both been the results of similar processes and that, therefore, the more I understand about my family and my position in it the more I will understand family process in general. These are insights I can share.

From the personal point of view I should also like to make a passing comment on what I have most obviously avoided, namely the effect on one's nuclear family if one tries to obtain change in one's extended family. To talk publicly about relationships in this area is to get too personal; on the other hand, I would not want to imply, by ignoring that area, that there are no repercussions.

It may also be worth noting that my wife received several notes of thanks. This was quite surprising since I did not involve her in one single detail, having had the entire affair catered down to the silverware, chairs and tables, and since all correspondence and phone calls to set up the party came only from me; no one had even spoken to my wife during the preparations.

Finally, I should like to enter a disclaimer. When this paper was delivered, some heard it as playing God and suggested that I should have warned my family about what I was trying to do. Let me state clearly, therefore, that I knew I could not be fully aware of the results. This is not to say I had no fears, trepidations, or fantasies. (None of my fantasies about deaths and suicides materialized—perhaps because fantasies come out of the system as it exists. If individuals are to be seen as symptoms of the family, so must their fantasies.) Things had been the way they had been for an awfully long time; members of the family were suffering now because of the irresponsibility (dependency?) of others. I decided, therefore, I would take responsibility only for my own feelings and behavior and each other member of the family would have to take responsibility for his.

In no way, therefore, do I take credit for any of the changes I have described in my family, for in no way can I prove that my new inputs produced the new outputs. But I do believe that few of the things I

did would have had the same effect on the family if anyone else would have done them, and if that is true, it is not because of any special attribute, talent, or personality factor that resides within me, but because of where I am on the genogram.

Address reprint requests to 6 Wynkoop Court, Bethesda, Md. 20034.