

Welcome to *Ecology 101*

Premise of course:

Ecosystems approach

- a. Physical attributes
- b. Energy flow
- c. Productivity

Readings:

Required:

The Diversity of Life, Edward O. Wilson

Sand County Almanac, Aldo Leopold

Ecology: A Bridge Between Science and Society,
Eugene P. Odum

Recommended:

Science Times

Science

Nature

Grading

1. Midterm: 50%

2. Final: 50%

Examination format:

Multiple choice, true/false, short answer, essay

Schedule:

September

Introduction
Basic Principles I – Evolution of Ecosystems
Basic Principles II – Species and the Niche Concept
Basic Principles III – Energy Flow and Trophic Levels
Biogeochemical Cycles I

October

Biogeochemical Cycles II
Rivers

MIDTERM EXAMINATION

Lakes
Estuaries and Wetlands

November

The Oceans
Coral Reefs
Rain forests

December

Hardwood and Boreal Forests

FINAL EXAMINATION

Websites:

Required:

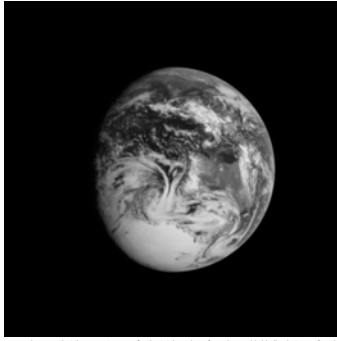
[www.http://ci.columbia.edu/ci/eseminars/1111s_detail.html](http://ci.columbia.edu/ci/eseminars/1111s_detail.html)
[www.http://streamecology.org](http://streamecology.org)
[www.http://IES.org](http://IES.org) (Institute for Ecosystems Study)

Recommended:

www.medicalecology.org

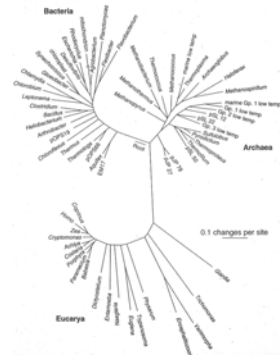
[www.http://NASA.gov](http://NASA.gov)
, then go to Earthwatch
[www.http://NOAA.gov](http://NOAA.gov)

Is That All There Is?

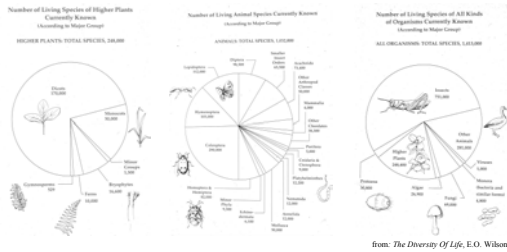


"Right now we can only guess that the correct answer for the total number of species worldwide lies between 2 and 100 million."

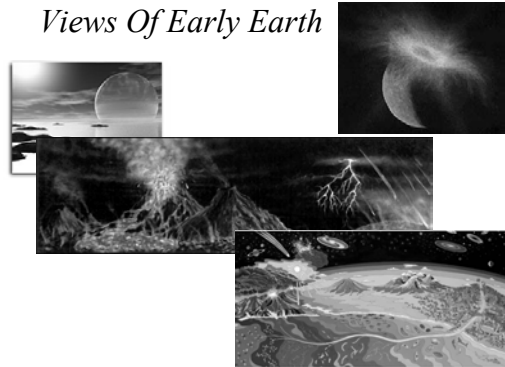
Life on Earth



The Diversity Of Life

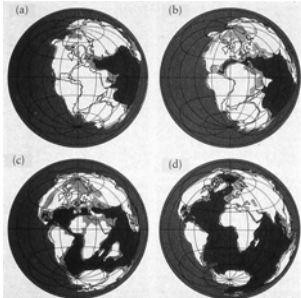


Views Of Early Earth



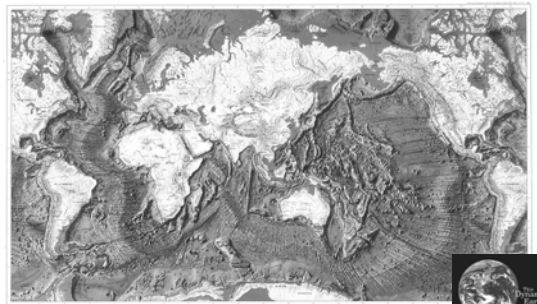
"Drifting Apart"

225 MYA



Now

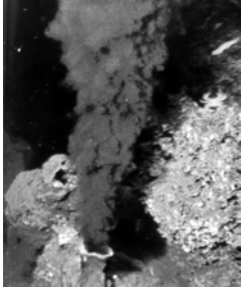
Still Drifting After All These Years



THE FLOOR OF THE OCEANS



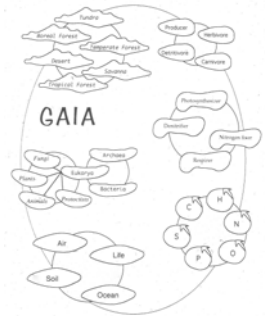
Life Without The Sun's Help



Extremophiles Rule!



GAIA Hypothesis



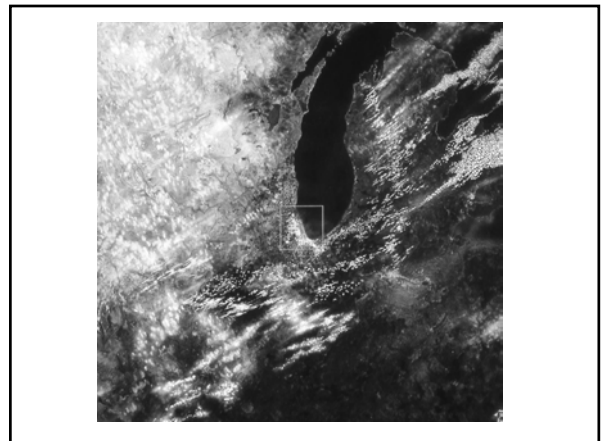
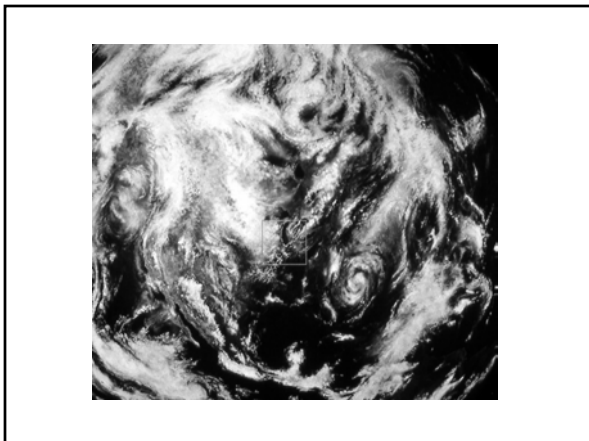
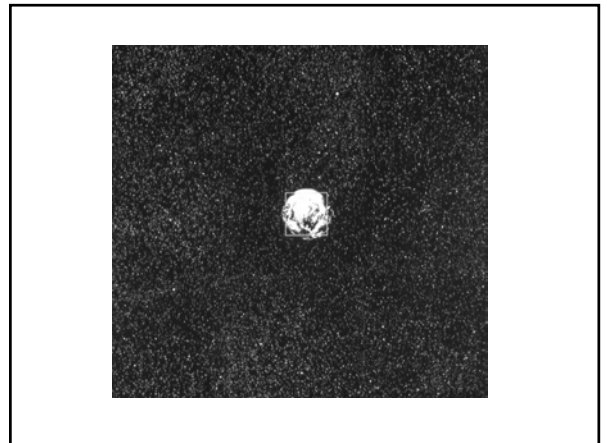
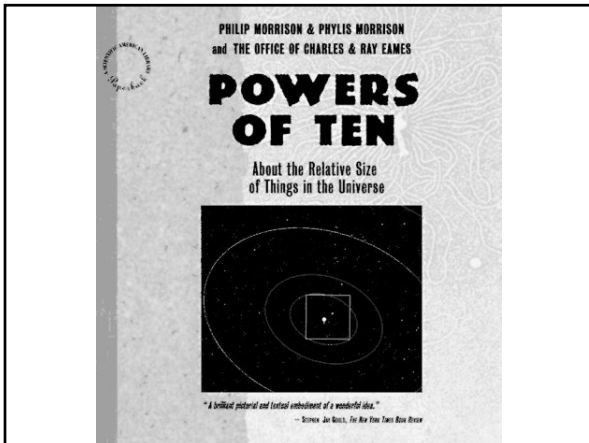
Some General Ecological Principles

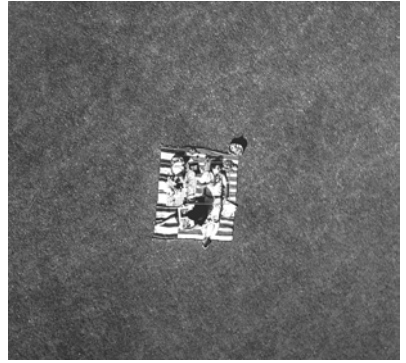
Ecosystem Ecology

Describing Ecosystems

1. Identify a definable geographic region (e.g. grassland prairie)
2. Identify all plants and animals within that region (i.e., the biodiversity index)
3. Study how these disparate groups form associations of food chains and food webs (i.e. form ecosystems).
4. Study the flow of energy through these associations (i.e., measure productivity)

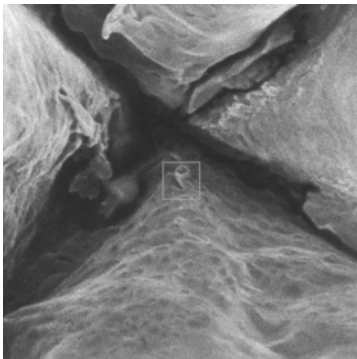
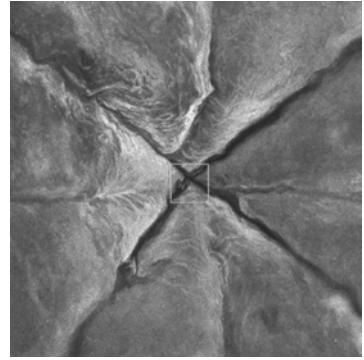
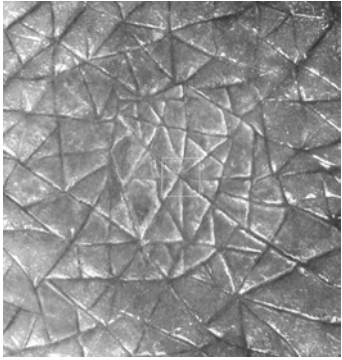
Levels of Complexity



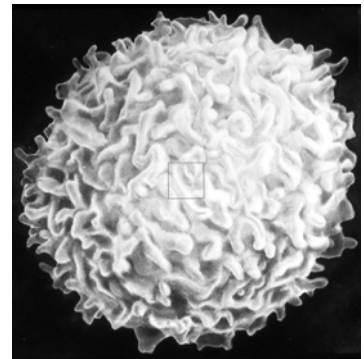


Why is this man sleeping?

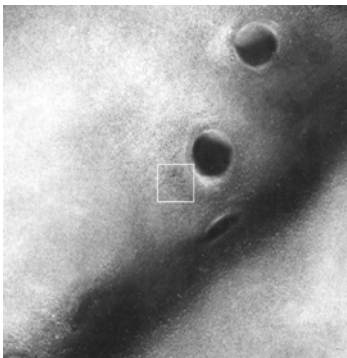




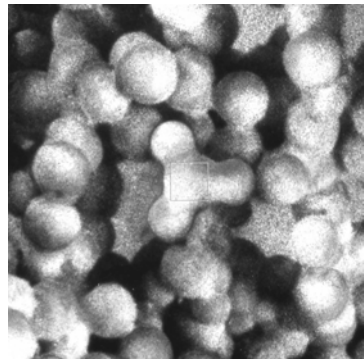
Lymphocyte



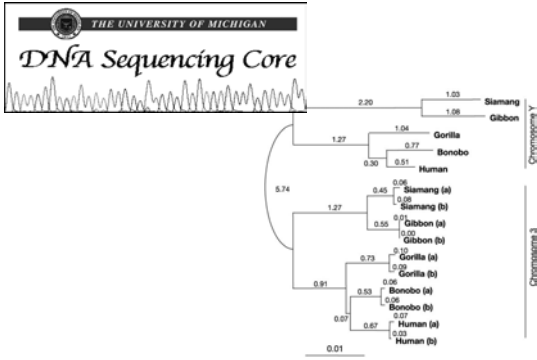
Nuclear Envelope



Chromosomal DNA



We have come a long way in just 20 years

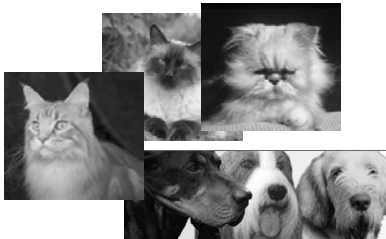


What Is A Species?*



* Variations in a theme. One snail species, many varieties.

How Many Species of Dogs And Cats Are There?



One!

Two Species Or One?



Study: Human DNA Neandertal-Free

By Jennifer Veigas, Discovery News

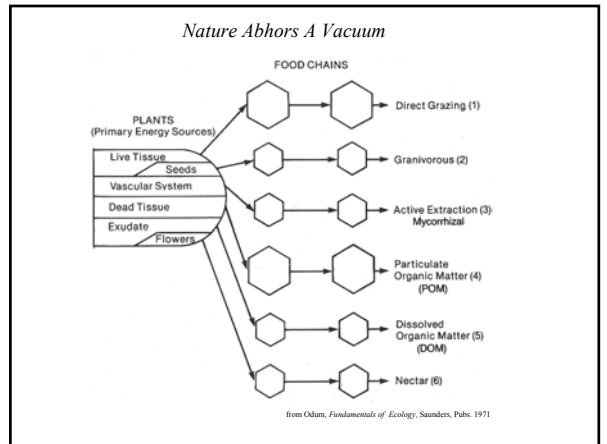
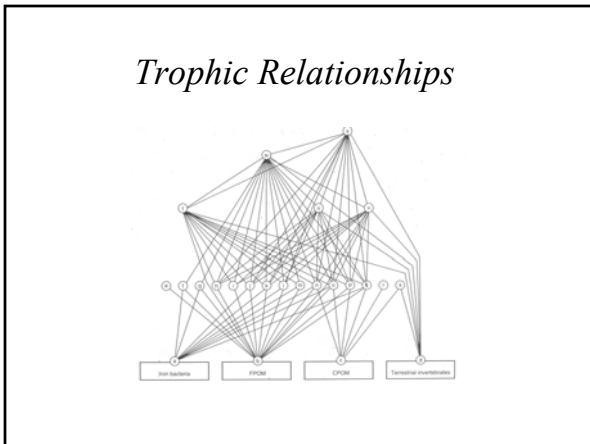
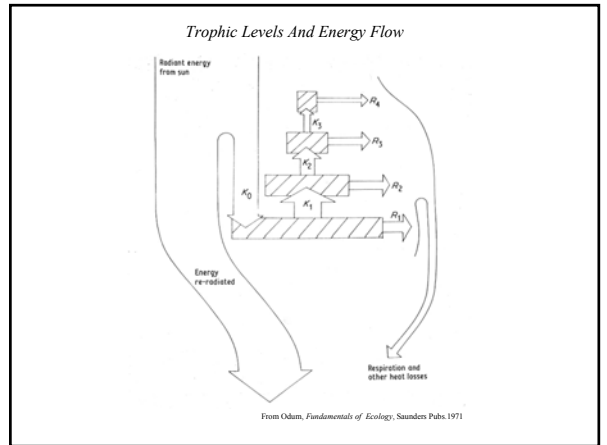
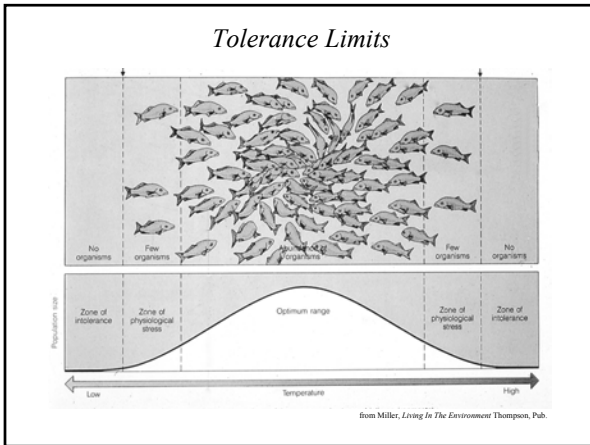
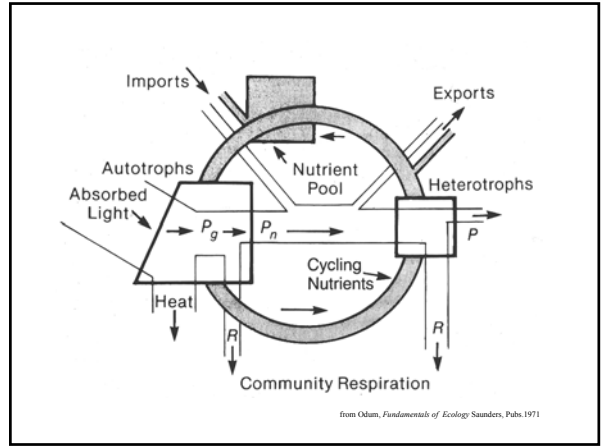
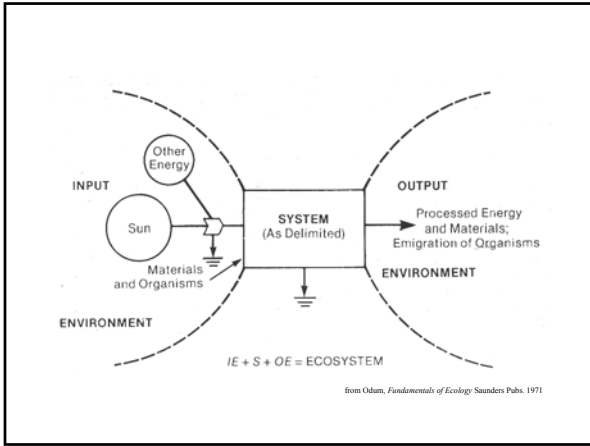
Cro-Magnon vs. Neandertal

May 12, 2003 — Neandertals did not contribute to the gene pool of modern humans, according to a recent study that compared the DNA of two ancient Cro-Magnons with that of four Neandertals.

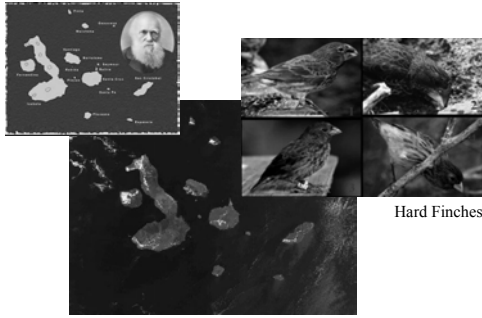
While Neandertals and early humans coexisted in Europe for a few thousand years 40,000 years ago, the findings suggest they did not interbreed, an action that would have made Neandertals a direct ancestor of modern humans.

The study also supports the "Out of Africa" theory. According to this view, modern humans evolved in East Africa and then spread into Europe and Asia through the Middle East.





The Galapagos Islands

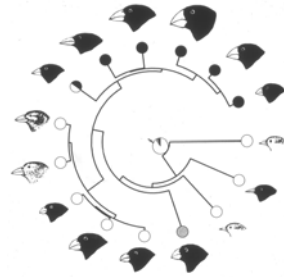


Hard Finches

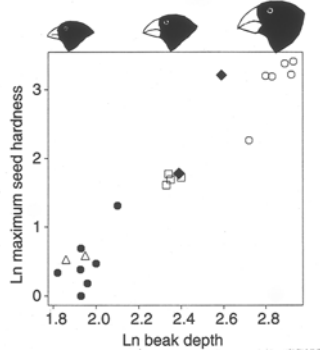
Learn more: <http://www.talkorigins.org/faqs/wells/finches.html>

Photo: NASA

Genetic Relationships Among Darwin's Finches Beak Size and Shape



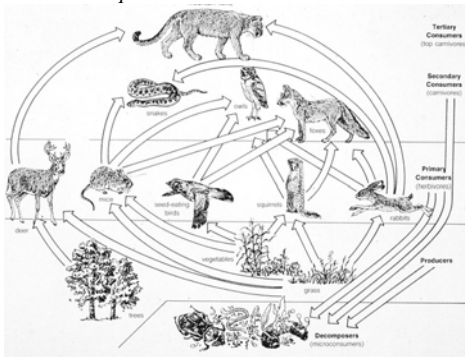
Evolution of Darwin's Finches



An Early Food Web

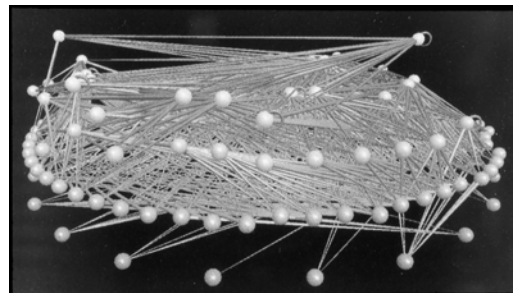


Trophic Levels and Food Webs



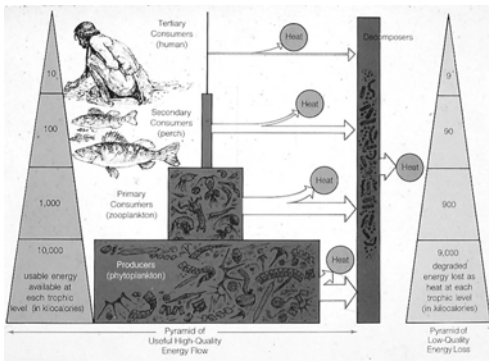
from Miller, *Living In The Environment* Thompson, Pub

Trophic Levels and Food Webs: The Complexity of Interactions



Science Magazine

Food Pyramid



from Miller, *Living In The Environment*, Thompson, Pub.

Food Pyramids



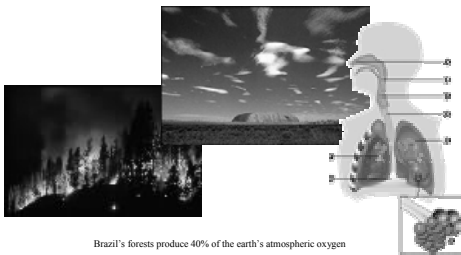
WebElements: the periodic table on the world-wide web
<http://www.webelements.com/>

1	2	3	4	5	6	7	8	9	10	11	12	13	14	15	16	17	18
H	He																
Li	Be											B	C	N	O	F	Ne
Na	Mg											Al	Si	P	S	Cl	Ar
K	Ca	Sc	Ti	V	Cr	Mn	Fe	Co	Ni	Cu	Zn	Ga	Ge	As	Se	Br	Kr
Rb	Sr	Y	Zr	Nb	Mo	Tc	Ru	Rh	Pd	Ag	Cd	In	Sn	Sb	Te	I	Xe
Cs	Ba	La	Hf	Ta	W	Re	Os	Ir	Pt	Au	Hg	Tl	Pb	Bi	Po	At	Rn
Fr	Ra	**	Lr	Rf	Db	Bh	Hs	Mt	Ds	Uuu	Uub	Uuq					
*lanthanoids		La	Ce	Pr	Nd	Pm	Sm	Eu	Gd	Tb	Dy	Ho	Er	Tm	Yb		
**actinoids		Ac	Th	Pa	U	Np	Pu	Am	Cm	Bk	Cf	Es	Fm	Md	No		

Biogeochemical Cycles:

- Oxygen
- Carbon
- Sulfur
- Nitrogen
- Phosphorous
- Calcium

Oxygen Cycle



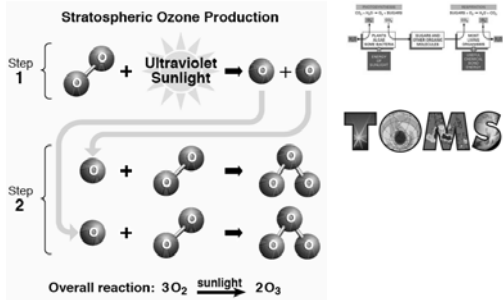
Brazil's forests produce 40% of the earth's atmospheric oxygen

Oxygen Cycle

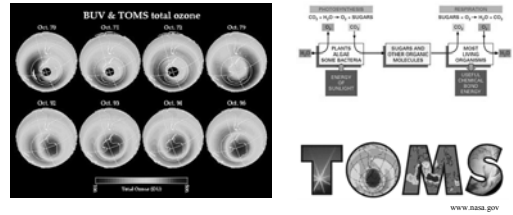


Image obtained from http://www.accessscience.com/ART234344_P001.html

Oxygen Cycle



Oxygen Cycle



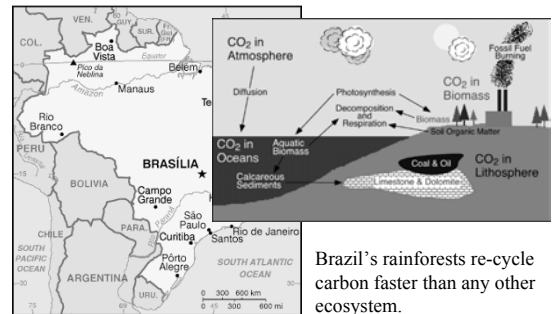
Depletion of ozone leads to ecosystem health risks

Carbon Cycle

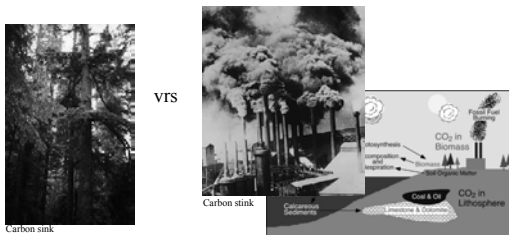


Temperate rainforests store vast amounts of carbon, both above and below ground.

Carbon Cycle

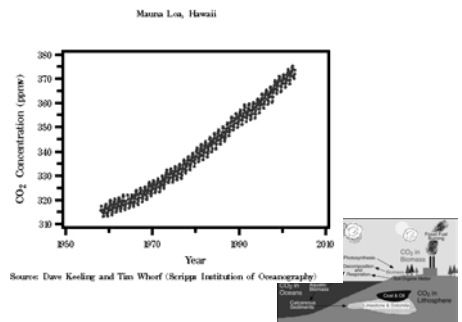


Carbon Cycle



Today, the earth's atmosphere is accumulating CO₂ faster than it can be sequestered.

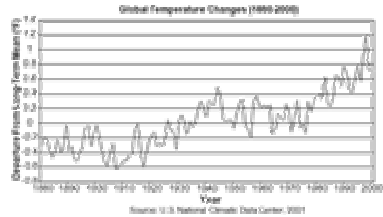
Carbon Cycle



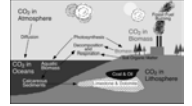
Carbon Sinks:

1. Marine viruses and phytoplankton
2. Forests
3. Coral reefs

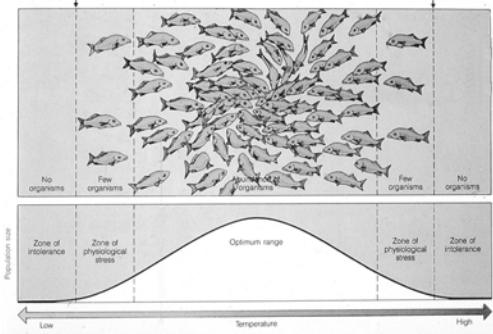
Carbon Cycle



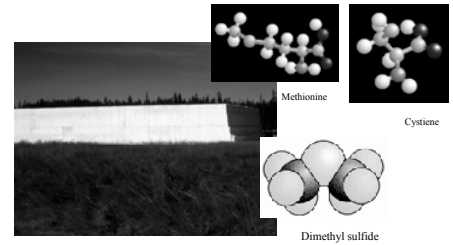
The earth's "core" temperature is rising



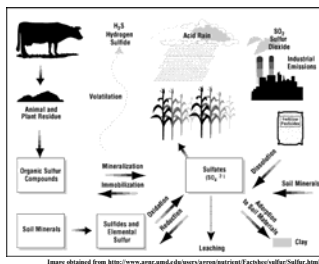
Nature Is "Re-shuffling" The Deck As The Environment Changes



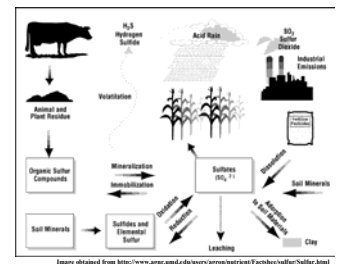
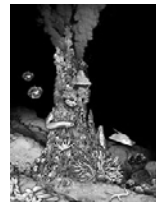
Sulfur Cycle



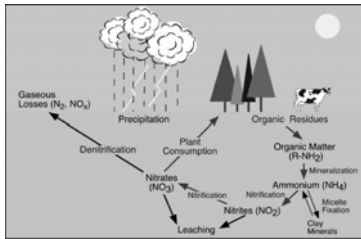
Sulfur Cycle



Sulfur Cycle



Nitrogen Cycle



Nitrogen Cycle*

Ultrastructure of root nodule bacteria

Root nodules

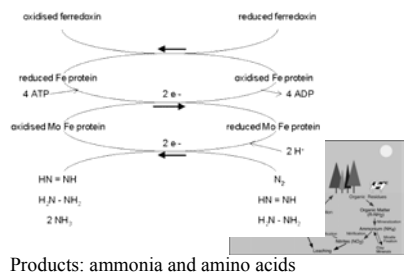
Nitrogen Fixation by Symbiotic and Free-Living Spirochetes

T. G. Lilburn,^{1,2} K. S. Kim,² N. E. Ostrem,² K. B. Bysak,² J. R. Leadbetter,² J. A. Brezina^{1,2*}

*what is wrong with this picture?

Corn is not a legume

Nitrogen Cycle



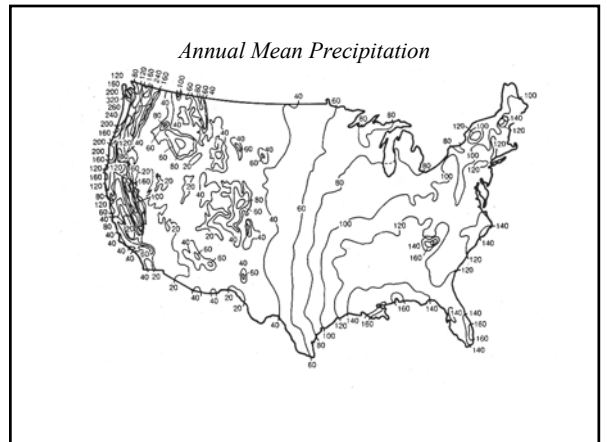
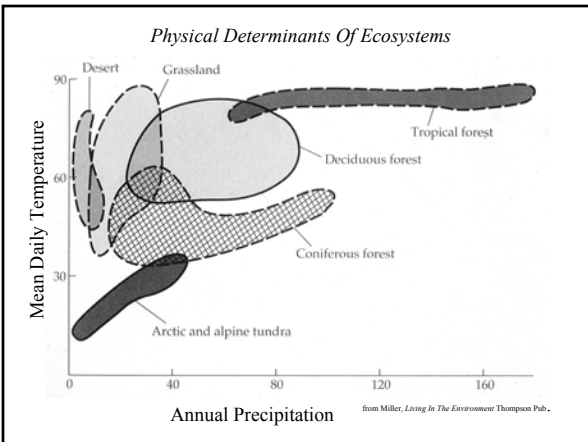
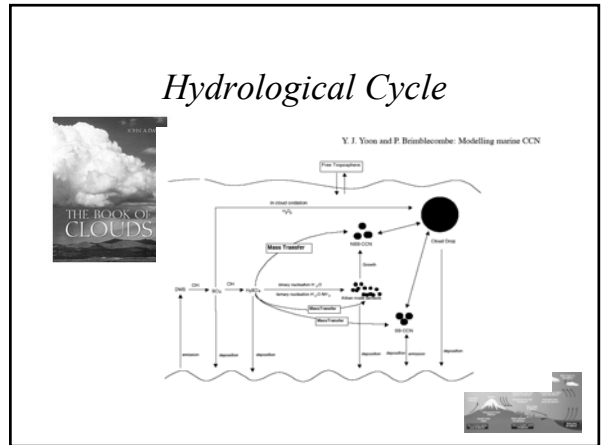
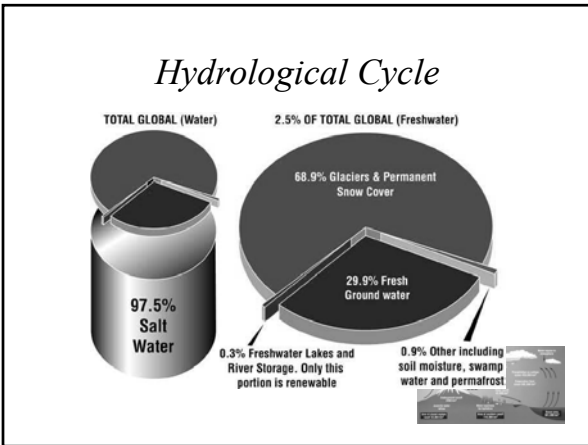
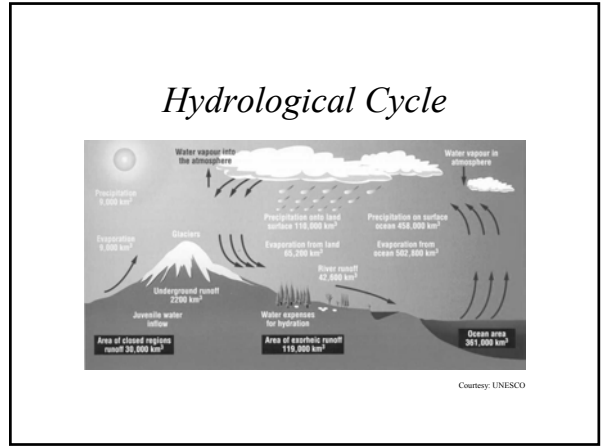
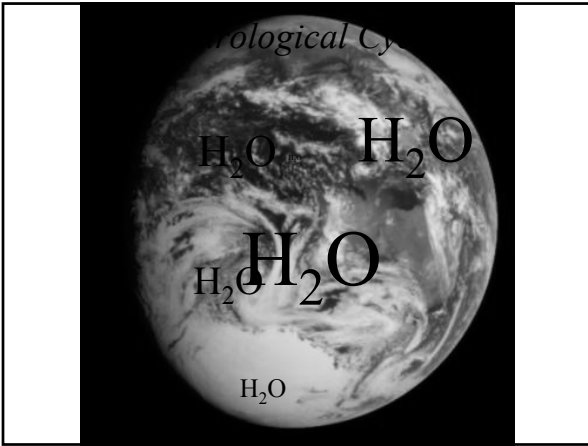
What is wrong with this picture?



The Earth - From Space
A Satellite View of The World

Courtesy NASA

No clouds



Ecozones



The Earth - From Space

A Satellite View of The World

Courtesy NASA

