

Potential Impact of Low Efficacy HIV-1 Vaccines in Populations with High Rates of Infection



R. M. Anderson; J. Swinton; G. P. Garnett

Proceedings: Biological Sciences, Volume 261, Issue 1361 (Aug. 22, 1995), 147-151.

Stable URL:

<http://links.jstor.org/sici?sici=0962-8452%2819950822%29261%3A1361%3C147%3APIOLEH%3E2.0.CO%3B2-C>

Your use of the JSTOR archive indicates your acceptance of JSTOR's Terms and Conditions of Use, available at <http://www.jstor.org/about/terms.html>. JSTOR's Terms and Conditions of Use provides, in part, that unless you have obtained prior permission, you may not download an entire issue of a journal or multiple copies of articles, and you may use content in the JSTOR archive only for your personal, non-commercial use.

Each copy of any part of a JSTOR transmission must contain the same copyright notice that appears on the screen or printed page of such transmission.

Proceedings: Biological Sciences is published by The Royal Society. Please contact the publisher for further permissions regarding the use of this work. Publisher contact information may be obtained at <http://www.jstor.org/journals/rsl.html>.

Proceedings: Biological Sciences
©1995 The Royal Society

JSTOR and the JSTOR logo are trademarks of JSTOR, and are Registered in the U.S. Patent and Trademark Office. For more information on JSTOR contact jstor-info@umich.edu.

©2003 JSTOR

<http://www.jstor.org/>
Tue May 27 10:42:36 2003

Potential impact of low efficacy HIV-1 vaccines in populations with high rates of infection

R. M. ANDERSON, J. SWINTON AND G. P. GARNETT

Wellcome Centre for the Epidemiology of Infectious Disease, University of Oxford, Department of Zoology, South Parks Road, Oxford OX1 3PS, U.K.

SUMMARY

A safe and effective HIV vaccine to prevent infection and/or to moderate disease is urgently needed. Research progress has been slower than anticipated for a variety of reasons including uncertainty over which immunogen to use (i.e. recombinant subunit envelope proteins or whole HIV-1 products), confusion on which immunological markers best correlate with protection, the relevance of the HIV-1 chimpanzee model to infection in humans and the significance of the rapid evolution of HIV-1, with different clades of the virus emerging in different parts of the world. However, what some would interpret as encouraging results, from Phase I and II trials of recombinant envelope glycoprotein vaccines, have raised the question of whether the time is right to start Phase III trials in humans with immunogens that may have low to moderate efficacy. By using mathematical models and data from epidemiological studies, we examine the potential impact of such vaccines within heterosexual communities with high rates of infection. Analyses suggest that it will be difficult to block HIV-1 transmission even with very high levels of mass vaccination. The cost of sustaining high levels of herd immunity with a vaccine of short protection duration is likely to be high. However, assessments of impact over the long duration of an HIV-1 epidemic indicate that many cases of HIV infection and associated mortality can be prevented by immunogens with efficacy of 50% or less and a five year protection duration. These analyses add some support to the view that proceeding with Phase III efficacy trials may be appropriate in high HIV transmission regions even if the consensus opinion on potential efficacy of the immunogen is that it will be low.

1. INTRODUCTION

The spread of HIV continues unabated in much of the world, with the World Health Organization (WHO) estimating that over 16 million people worldwide had acquired the infection by mid-1994 (WHO 1994*a*). Over 90% of these cases have occurred in developing countries with sexual intercourse between men and women and vertical transmission from mother to infant being the dominant routes of transmission. Interventions to slow the spread of HIV by using education, condom distribution and the treatment of cofactor sexually transmitted diseases (STDs) have had limited effect in poor regions of the world with inadequate infrastructures for health care and other services. Progress on vaccine development has been eagerly watched by health officials in developing countries, and some dismay resulted from a decision by the National Institutes of Health in the U.S.A. in June 1994 not to proceed, as yet, with Phase III efficacy trials of a number of available recombinant virus envelope products (i.e. gp120) (Cohen 1994). In October 1994, a WHO Committee came to a somewhat different conclusion: to recommend that the decision to proceed should be based on the public health needs of particular countries. It noted that the sheer magnitude of the AIDS problem in some areas

necessitates proceeding with immunogens of uncertain efficacy provided safety, ethical and trial design issues are carefully addressed (Moore & Anderson 1994).

Based on an understanding of the transmission dynamics of the target infectious agent, a framework to assess the potential impact of vaccines with defined efficacy (the percentage of those immunized protected against infection) and protection duration has been developed, to guide both the design of immunization programmes and the monitoring of their impact for childhood respiratory infections and STDs such as Hepatitis B, for which efficacious vaccines are available (Anderson & May 1991; Anderson *et al.* 1992). These techniques and concepts have recently been applied in the HIV context and with a focus on gay male communities in western countries (Anderson *et al.* 1991; Blower & McLean 1994). The mathematical models used so far are simple in design and ignore sources of heterogeneity that are known to have a major impact on HIV transmission, for example, mixing patterns between groups of individuals with varying degrees of sexual activity (rates of partner acquisition) (Jacquez *et al.* 1988; Garnett & Anderson 1993). We employed two approaches in examining the impact of low efficacy HIV immunogens, namely, the derivation of analytical criteria for defining the level of coverage with a vaccine of specified efficacy and

protection duration, required to eradicate transmission and numerical simulations of impact on cumulative AIDS cases throughout the duration of an epidemic.

2. ANALYTICAL CRITERIA FOR ELIMINATION

To block transmission, the value of the case reproductive rate R_0 (the average number of secondary cases of infection generated by one primary case in a susceptible population) must be reduced to less than unity (Anderson & May 1991). In the case of STDs, where much heterogeneity in sexual behaviour prevails, we need to capture finer stratifications of the population with the term $R_0(i, j)$ denoting the secondary cases generated by people in group i via contact with individuals in group j . This definition facilitates analysis of the influence of sexual spatial, or age related mixing patterns (Anderson 1991) and models based upon it reveal that an infection may persist throughout the total population when in the case of sexual mixing, the majority of the $R_0(i, j)$ values are less than unity, provided a small core of highly sexually active individuals ($R_0(i, j) \geq 1$) have sufficient contact with the lower activity groups. We consider a mathematical model of the transmission dynamics of HIV (along conventional lines; Anderson *et al.* 1986) defining changes over time in the numbers susceptible, infected and protected by vaccination in sexual activity class i as $x_i, y_i,$ and $z_i,$ respectively. Sexual-activity class is defined by stratification of the sexually active population into a class based on rates of sexual partner change. For simplicity we consider a single sex population but there is not great difficulty in generalizing the results to the two sex (heterosexual) case. We restrict attention to the sexually active population, which is held constant in size with natural death rate μ and infectious related death rate $\mu + \alpha$ (the average duration of stay in the infected class is $(\mu + \alpha)^{-1}$). Each activity class is replenished by new susceptible recruits at a rate of $\phi_i = \mu n_i + \alpha y_i,$ where $n_i = x_i + y_i + z_i.$ The per capita rate, or force, of infection for individuals in group i is defined as

$$\lambda_i = \beta c_i \sum_j q_{ij} (y_j / n_j), \tag{1}$$

where c_i is the effective rate of sexual partner change for those in class $i,$ β is the transmission coefficient and q_{ij} is the mixing matrix whose elements are defined as (see Garnett & Anderson 1993);

$$q_{ij} = \delta_{ij} \epsilon + (1 - \epsilon) R_{oi} n_j / (\sum_k R_{ok} n_k). \tag{2}$$

Here, ϵ is a parameter which measures the degree of assortative mixing (like-with-like) (when $\epsilon = 1$ mixing is fully assortative with no contact between groups, $\epsilon = 0$ denotes random mixing) (Garnett & Anderson 1993 *b*). The Kronecker δ_{ij} is equal to unity if $i = j$ and zero otherwise. The within group case or basic reproductive rate R_{oi} is given by

$$R_{oi} = \beta c_i / (\mu + \alpha).$$

This parameter defines the average number of secondary cases of infection generated by one primary

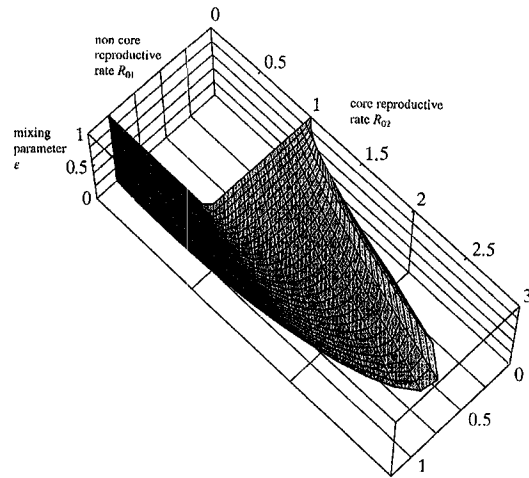

Figure 1. The eradication criterion (equation (6) in the main text) is displayed for a two group model in the absence of vaccination ($\sigma = f = 0$), with the non-core group taken to be 20 times the size of the core-group. For the mixing parameter $\epsilon: 0 =$ random; $1 =$ assortative. Outside the surface, HIV infection will persist, whereas inside the surface it will not ($y_1 = y_2 = 0$).

case (in a susceptible population) when group i has no contact with other groups. Blanket vaccination (every person in the sexually active population is offered immunization) at an annual rate p_i and entry vaccination (immunization before joining the sexually active age classes) of a fraction f_i of those entering each activity class, are mirrored by removals from the susceptible class at a rate $\sigma_i x_i$ and $f_i \phi_i h,$ respectively, where h is vaccine efficacy (the fraction of those immunized who are protected), and $\sigma_i = \ln(1 - p_i h).$

The protection against infection provided by the vaccine is lost at a rate γ to give a mean duration of protection of γ^{-1} time units. The equations of the model are as follows:

$$dx_i/dt = \phi_i(1 - f_i h) - \sigma_i x_i - \lambda_i x_i - \mu x_i + \gamma z_i, \tag{3}$$

$$dy_i/dt = \lambda_i x_i - (\mu + \alpha) y_i \tag{4}$$

$$dz_i/dt = f_i h \phi_i + \sigma_i x_i - (\mu + \gamma) z_i. \tag{5}$$

Local stability analysis for the infection free state ($y_i = 0$ for all i) show that the point at which eradication occurs is given by:

$$\sum_i n_i R_{oi} \prod_j [(\delta_{ij} + \epsilon(1 - \delta_{ij})) (1 - f_j) R_{oj} - (1 + \hat{\sigma}_j)] = 0 \tag{6}$$

where $f_i = [\mu / (\mu + \gamma)] f_i$ and $\hat{\sigma}_i = [1 / (\mu + \gamma)] \sigma_i.$

Criteria for persistence can be derived from equation (6) and figure 1 shows an example based on a two group model in the absence of vaccination (representing those with low (group 1) and high (group 2) rates of sexual partner change), where a surface, separating regions of HIV persistence and extinction, is plotted for different values of R_{01} and R_{02} (the

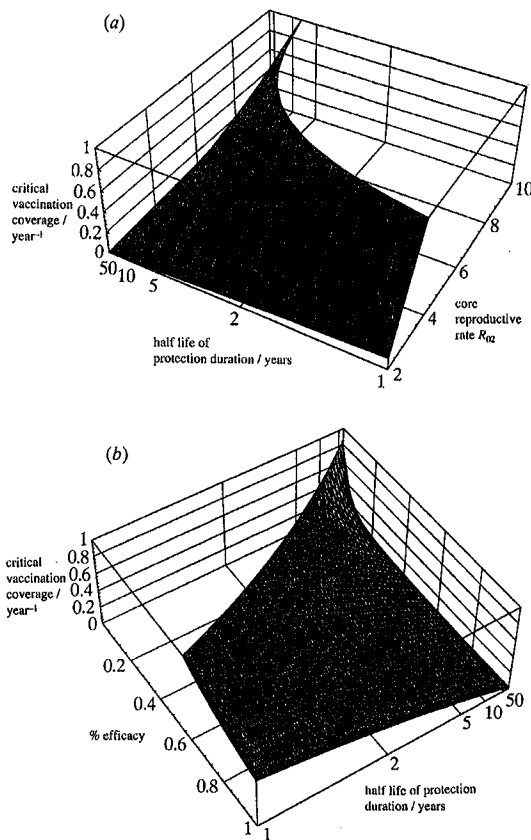

Figure 2. Critical annual vaccination rates that must be achieved to eradicate HIV infection in a two-group model. Graph (a) shows the dependence on core activity rates and on duration of protection. Model structure and parameters as in figure 1, but with blanket vaccination, with efficacy h , of both low activity ($R_{01} = 0.9$) and high activity groups and a mixing parameter, $\epsilon = 0.25$, set to mirror moderate to low in the assortative mixing.

Note that in the region where required vaccine coverage exceeds one year (i.e. more than 100% of the target population), blanket vaccination must occur at intervals of shorter than one year to achieve eradication. Graph (b) shows the dependence of critical annual vaccination rates on vaccine efficacy and duration of protection. Model structure and parameters as in Figure 1, but with blanket vaccination of both low activity ($R_{01} = 0.9$) and high activity ($R_{02} = 4$) groups. Moderately assortative mixing ($\epsilon = 0.25$).

reproductive rates in groups 1 and 2, in the absence of contact with the other group). Note that as the value of R_{01} decreases, the magnitude of transmission success, R_{02} , in the high activity group required to permit HIV persistence, first moves from low (but is greater than one), to high and then to low (but is greater than one) again.

The impact of vaccination (whether cohort based, mass or targeted) can be assessed using this mathematical framework, by simple modifications which record rates of vaccine uptake, efficacy and protection duration. The greatest impact for moderate levels of assortative mixing (as observed in empirical studies (Potterat *et al.* 1985; Garnett *et al.* 1994), is generated

by repeated blanket vaccination of susceptibles, but as illustrated in Figure 2a, b, for appropriate values of R_{01} and R_{02} (for heterosexuals in high transmission areas), blocking transmission will be difficult to achieve for any pattern of mixing. This is in accord with earlier analyses of imperfect vaccines (Smith *et al.* 1984; McLean & Blower 1993) but the present result derives from a more complex model that mirrors heterogeneity in sexual activity and different sexual mixing patterns.

3. INCIDENCE REDUCTION: NUMERICAL RESULTS

We now turn to a more complex model for two reasons. First, the previous analysis demonstrates the difficulty of completely blocking transmission, a point of particular relevance to HIV spread in developing countries. Accordingly we want to examine the impact of low efficacy vaccination on the number of AIDS cases arising over defined periods of immunization. Second, it is important to consider the way in which our conclusions are affected by mirroring additional biological complexity in the model.

The framework is complex, involving age-structured mortality and fertility, distributed incubation and infectious periods, vertical transmission, heterogeneity in rates of sexual partner acquisition and mixing between different age and sexual activity classes of the two sexes (its structure and parameterization is detailed in Anderson *et al.* 1991; Garnett & Anderson 1994). Numerical simulation experiments were designed to mirror an epidemic of HIV in an urban centre in sub-Saharan Africa in which seroprevalence in the lowest risk group (pregnant women) attains a plateau of roughly 20%–25% over a period of 10–20 years, while that in the highest risk group (female sex workers) reaches 80% or more within a few years of introduction. This type of pattern has been recorded in a number of urban centres such as Nairobi, Kenya (see figure 3a). Two sets of simulated time courses of levels of HIV seroprevalence (in a population of one million), for vaccines of 50% or 20% efficacy and ten years of protection duration, are recorded in figure 3b, c. In each case, four time-courses are plotted representing: no vaccination, 90% or 60% coverage of the highest activity class, 90% or 60% coverage of the two highest sexual activity classes and 90% or 60% coverage of the total sexually active population. Figure 3d shows a record of the number of AIDS cases prevented 20 years after the introduction of immunization (ten years after the arrival of HIV-1), with 60% blanket coverage of the total population (sexually active), for vaccines with 20% and 50% efficacy with mean durations of protection of five years, ten years and lifelong. Even the poorest immunogen (20% efficacy, five years protection duration) prevents over 90000 cases of AIDS over 20 years. However, the number of doses administered to achieve this is high, because blanket vaccination must be repeated year after year. In all these calculations it is assumed that: (i) the vaccine is safe (i.e. no extra mortality or morbidity); (ii) the incubation period of AIDS in those immunized, but

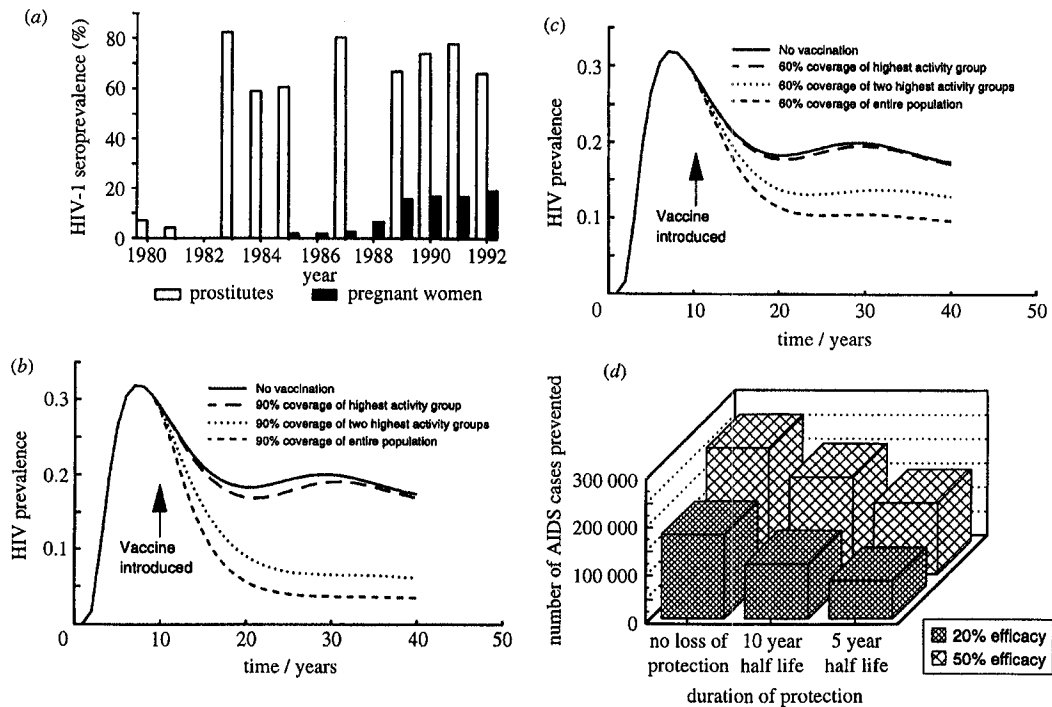

Figure 3. The impact of a low efficacy vaccine in a community with a high prevalence of HIV-1. Graph (a) shows the longitudinal trends in HIV-1 seroprevalence in prostitutes and pregnant women in Nairobi, Kenya (U.S. Bureau of the Census 1994). Graphs (b) and (c), show the prevalence of HIV in the sexually active population for a model simulation of viral spread in a population stratified by sex, age and sexual activity (defined in terms of rates of sexual partner acquisition). For a detailed description of the mathematical model of HIV-1 transmission and the parameters generating such an epidemic see Garnett & Anderson (1994). From year ten and thereafter, a percentage of susceptibles are vaccinated, of whom, only a proportion are effectively vaccinated and removed completely from risk of infection for a period of time. The mean duration of vaccine induced protection is ten years, with people moving from a vaccine protected to the susceptible class at a constant rate. In graph (b), 50% of vaccinations are effective and different sections of the community are targeted. The highest activity group is the five per cent of those sexually active with the highest rates of sexual partner acquisition, and the highest two groups make up 40% of the sexually active population. In graph (c), only 20% of vaccinations are effective. Graph (d), shows the number of AIDS cases prevented, i.e. the difference in the cumulative number of AIDS cases with and without vaccination over a twenty-year period. The population size changes because of AIDS associated mortality. The initial population size was one million with a 2.7% growth rate, which becomes negative at the peak of the epidemic. For 50% vaccine efficacy, 38%, 31% and 23% of AIDS cases are prevented in the cases of no loss of protection, a ten year half-life and a five year half-life respectively. The equivalent proportions of cases prevented for 20% vaccine efficacy are 26%, 18% and 12%.

not protected, is identical to that in unimmunized people: (iii) those vaccinated do not change their sexual behaviour (either increase or decrease activity as a result of immunization); and (iv) vaccination protects a proportion of people; not a proportion of sexual contacts made by each individual.

4. CONCLUSIONS

The main conclusion of this study is that even low efficacy vaccines, that only provide protection for a few years, can save many lives if significant coverage is maintained over many years. If phase III trials with recombinant protein immunogens (appropriately selected to match the predominant viral clade circulating in the target population (WHO 1994*b*; Walker & Fast 1994; Esparza & Osmanov 1993) reveal low-to-

moderate efficacy, the decision on whether or not to use such products more widely, may well depend on costs because maintaining a significant level of herd immunity will require high (and repeated) coverage. Similar issues pertain in the current debate on the community wide use in sub-Saharan Africa of a malaria vaccine whose efficacy was recently reported to be approximately 30% on the basis of a clinical trial in Tanzania (Alonso *et al.* 1994). Efficacy trials, with candidate HIV vaccines will be difficult to conduct, and even more so with low efficacy vaccines because very large samples of people in both treated and placebo arms will be required to detect changes in infection rates. Most importantly, very careful counselling will be needed to ensure that those in both arms of the trial fully appreciate that vaccination may not protect against HIV infection.

We thank the Wellcome Trust for research grant support.

REFERENCES

- Alonso, P. L., Smith, T., Armstrong Schellenberg, J. R. M., Masanja, H., Mwanakusye, S., Urassa, H. *et al.* 1994 Randomised trial of efficacy of SPf66 vaccine against *Plasmodium falciparum* malaria in children in southern Tanzania. *Lancet*, **344**, 1175-1181.
- Anderson, R. B. 1991 The transmission dynamics of sexually transmitted diseases: the behavioural component. In *Human behaviour and sexually transmitted diseases in the AIDS era* (ed. J. N. Wasserheit *et al.*) (pp. 38-60). Washington, U.S.A.: Am. Soc. Microbiol.
- Anderson, R. M., Gupta, S. & May, R. M. 1991 The potential of community-wide chemotherapy or immunotherapy to control the spread of HIV-1. *Nature Lond.*, **350**, 356-359.
- Anderson, R. M. & May, R. M. 1991 *Infectious diseases of humans: dynamics and control*. Oxford University Press.
- Anderson, R. M., May, R. M., Boily, M.-C., Garnett, G. P. & Rowley, J. T. 1991 The spread of HIV-1 in Africa: Sexual contact patterns and the predicted demographic impact of AIDS. *Nature Lond.* **352**, 581-589.
- Anderson, R. M., May, R. M., Medley, G. F. & Johnson, A. 1986 A preliminary study of the transmission dynamics of the human immunodeficiency virus (HIV), the causative agent of AIDS. *IMA J. Math. appl. Med. Biol.*, **3**, 229-263.
- Anderson, R. M., Medley, G. F. & Nokes, D. J. 1992 Preliminary analyses of the predicted impacts of various vaccination strategies on the transmission of hepatitis B virus. In *The control of hepatitis B - the role of prevention in adolescence*, chapter 16 (*Conference Proceedings*) (ed. D. L. Bennet) (pp. 95-130). London: Gower Medical Publishing.
- Blower, S. M. & McLean, A. R. 1994 Prophylactic vaccines, risk behaviour change, and the probability of eradicating HIV in San Francisco. *Science, Wash.* **265**, 1451-1454.
- Cohen, J. 1994 Bumps on the vaccine road. *Science, Wash.* **265**, 1371-1373.
- Esparza, J. & Osmanov, S. 1993 The development and evaluation of HIV vaccines. *Curr. Opin. Infect. Dis.* **6**, 218-229.
- Garnett, G. P. & Anderson, R. M. 1993a Factors controlling the spread of HIV in heterosexual communities in developing countries: patterns of mixing between different age and sexually active classes. *Phil. Trans. R. Soc. Lond. B* **342**, 137-159.
- Garnett, G. P. & Anderson, R. M. 1993b Contact tracing and the estimation of sexual mixing patterns: the epidemiology of gonococcal infections. *Sex. Transm. Dis.* **20**, 82-91.
- Garnett, G. P. & Anderson, R. M. 1994 Balancing sexual partnerships in an age and activity stratified model of HIV transmission in heterosexual populations. *IMA J. Math. appl. Math. Biol.* **11**, 161-192.
- Garnett, G. P., Hughes, J., Anderson, R. M. *et al.* 1994 The determination of the sexual mixing pattern of patients attending STD and other clinics in Seattle, USA, by contact tracing. *Sex. Transm. Dis.* (Submitted.)
- Jacquez, J. A., Simon, C. P., Koopman, J., Sattenspiel, L. & Perry, T. 1988 Modelling and analyzing HIV transmission: the effect of contact patterns. *Math. Biosci.* **92**, 119-199.
- McLean, A. R. & Blower, S. M. 1993 Imperfect vaccines and herd immunity to HIV. *Proc. R. Soc. Lond. B* **253**, 9-13.
- Moore, J. & Anderson, R. M. 1994 The WHO and why of HIV vaccine trials. *Nature, Lond.* **372**, 313-314.
- Potterat, J. J., Rothenberg, R. B., Woodhouse, D. E., Muth, J. B., Pratts, C. I. & Fogle, J. L. 1985 Gonorrhoea as a social disease. *Sex. Transm. Dis.*, **12**, 25-32.
- Smith, P. G., Rodrigues, L. D. & Fine, P. E. M. 1984 Assessment of the protective efficacy of vaccines against common diseases using case-control and cohort studies. *Int. J. Epidemiol.* **13**, 87-93.
- Walker, M. C. & Fast, P. E. 1994 Clinical trials of candidate AIDS vaccines. *AIDS*, **8** (Suppl. 1), S213-S236.
- WHO 1994a *The HIV/AIDS pandemic: 1994 Overview*. WHO: Geneva.
- WHO 1994b WHO Network for HIV isolation and characterization. *AIDS Res. Hum. Retroviruses*, **10**, 1325-1341.

Received 30th January 1995; accepted 3rd March 1995