

Modeling Cochlear Dynamics

Christopher Bergevin

Department of Mathematics
University of Arizona

10/18/07

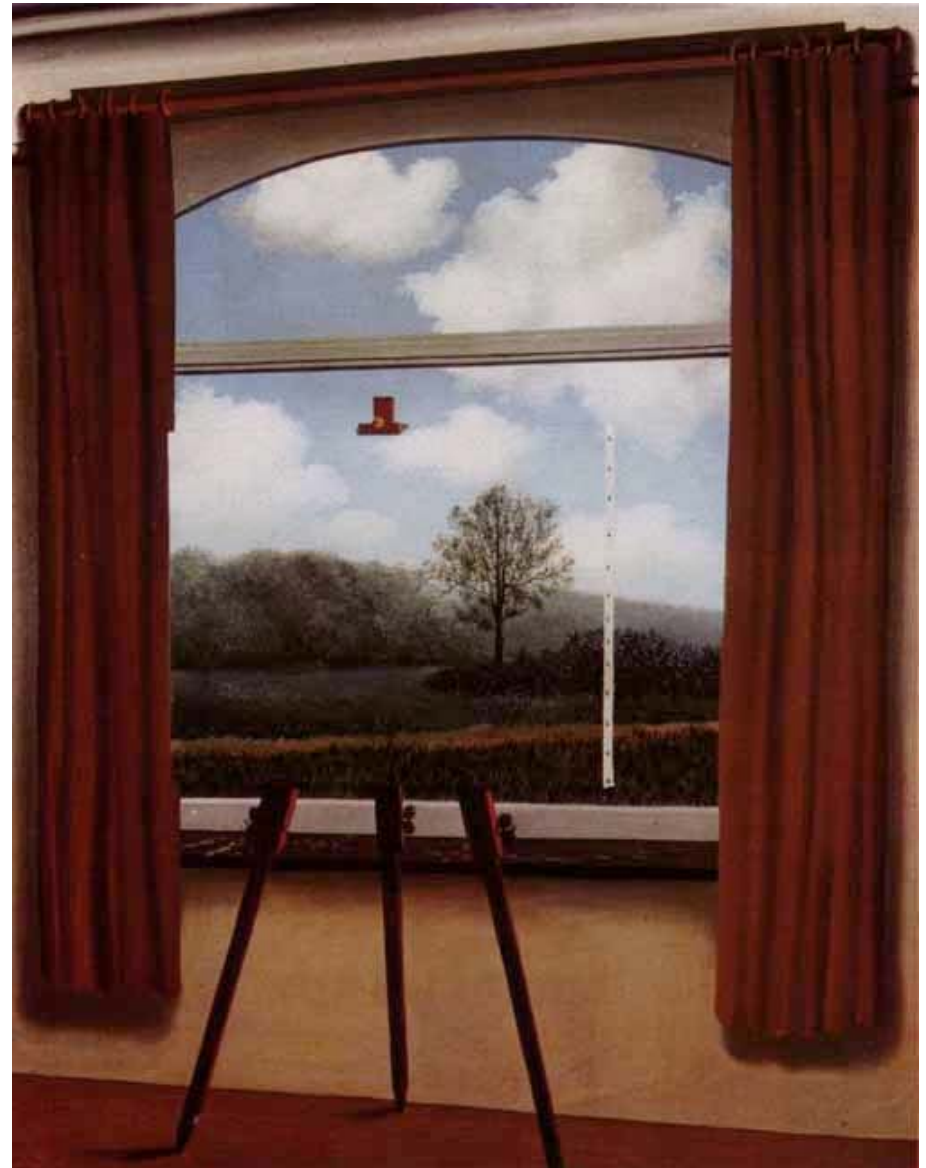

Rene Magritte

Disclaimer:

$$j \equiv \sqrt{-1} = i$$

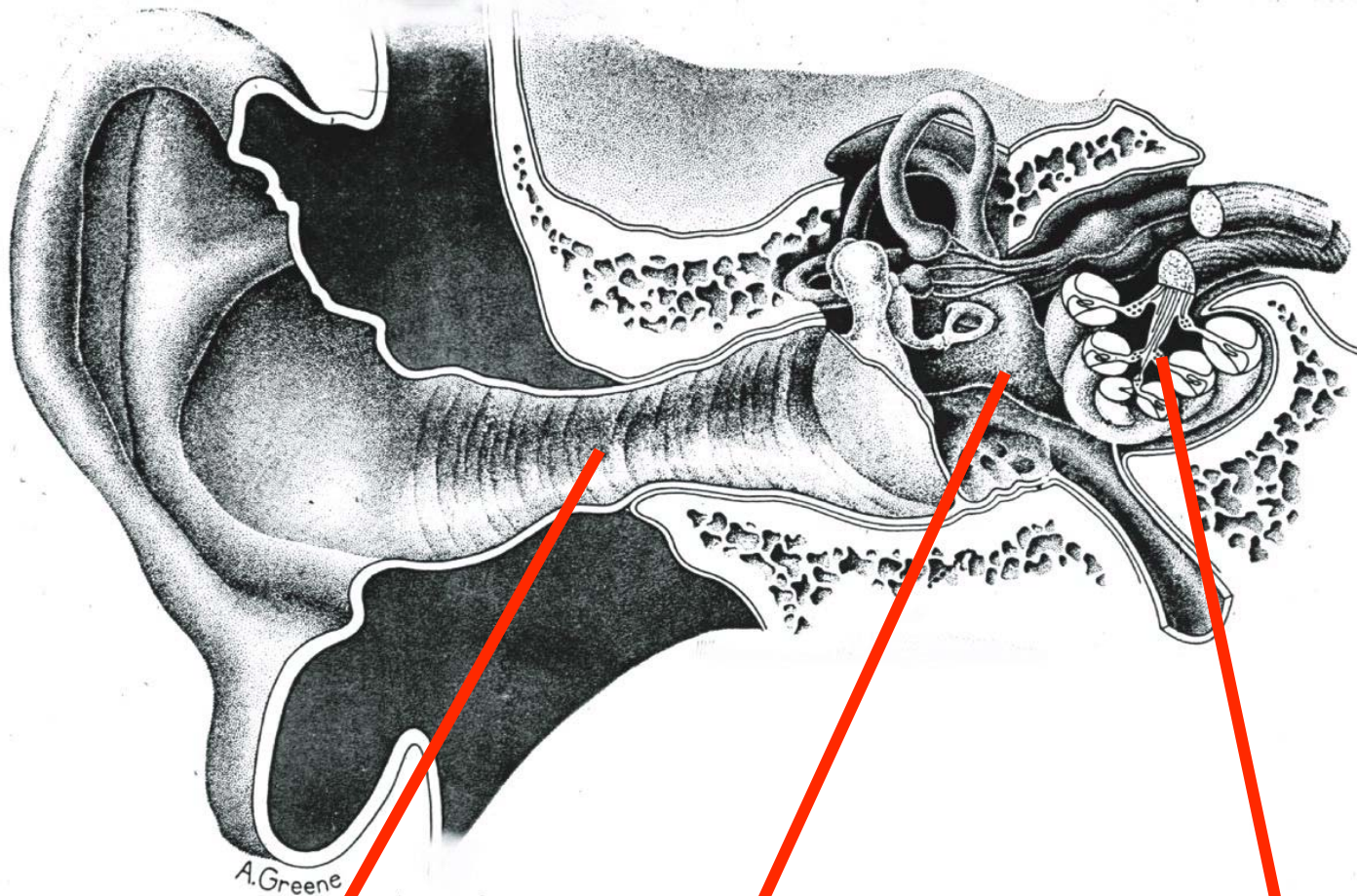

Outer ear
(pinna, ear canal &
ear drum)

Middle ear
(ossicles, *air-filled*)

Inner ear
(cochlea, *fluid-filled*)

Inner ear - Organ of Corti

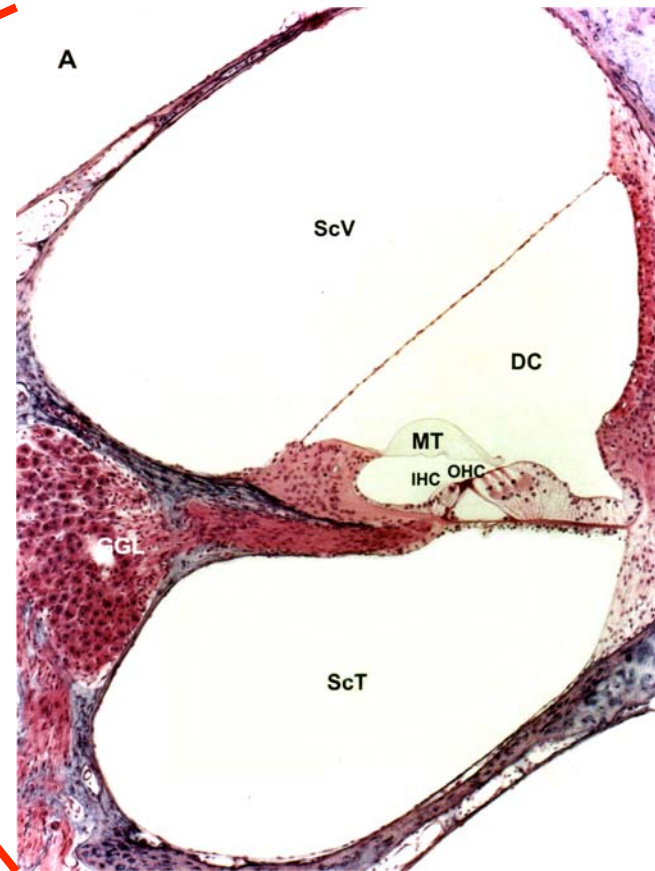
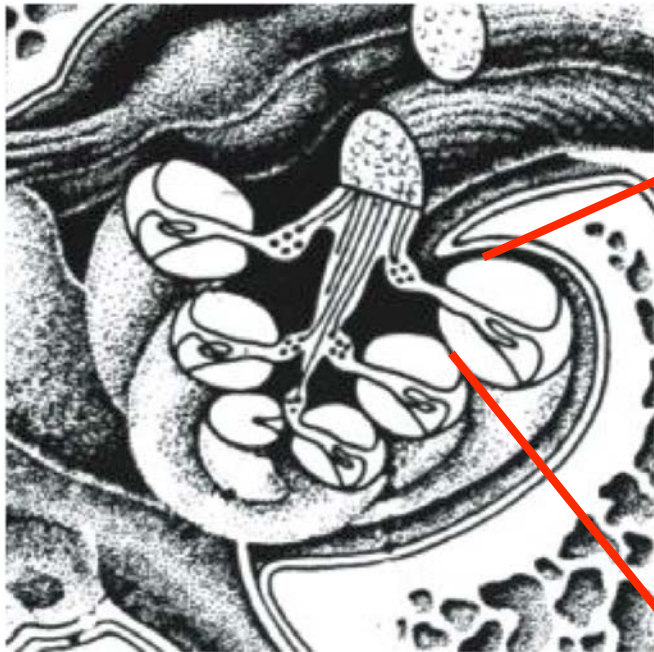

- Three fluid filled compartments
- Sensory complex sits atop a flexible membrane (*basilar membrane*)



Georg von Békésy (1899-1972)
(Nobel Prize in 1961)

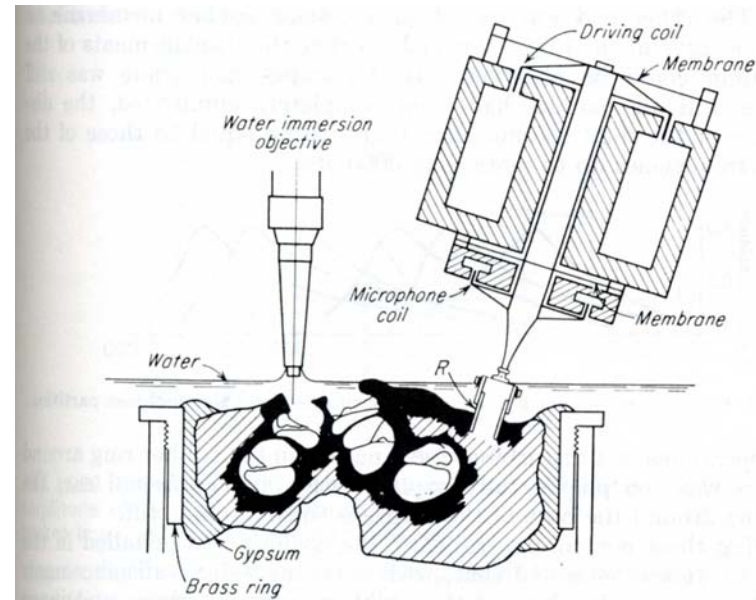

FIG. 11-48. Method of measuring the amplitude of vibration of the cochlear partition in response to volume displacements of the stapes.

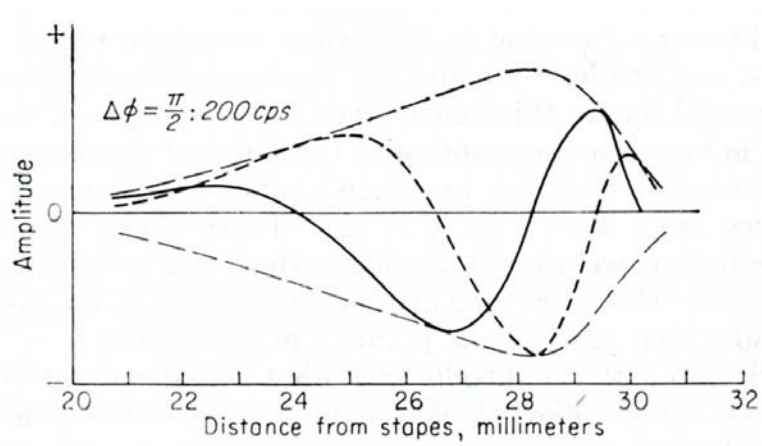

FIG. 11-59. Detail of the form of vibration of the cochlear partition for 200 cps at two instants within a cycle.

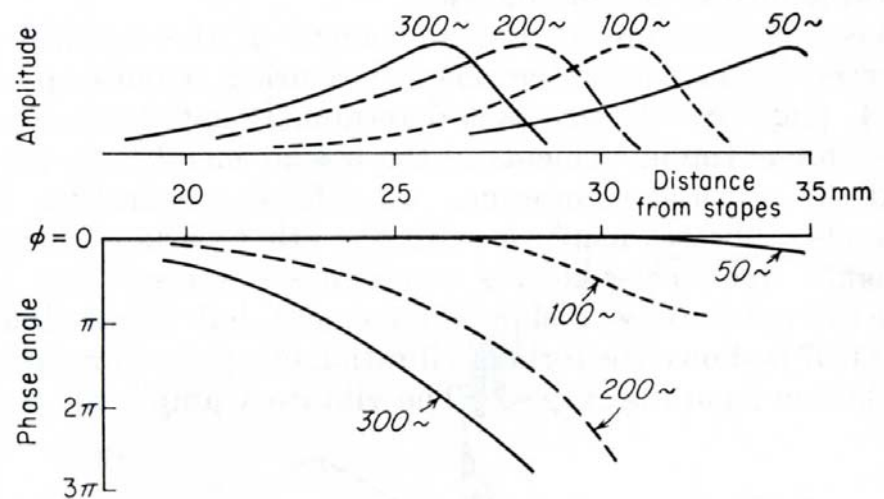

FIG. 11-58. Phase displacement and resonance curves for four low tones.

Question: Can we develop a model based upon the anatomy that captures the observed physiological features?

Goal: Model should serve as a foundation

⇒ 1-D transmission-line model solved using WKB approximation

Assumptions

- effect of coiling is negligible

(allows us to 'unroll' the cochlea)

- height of traveling wave is small relative to the height of the scalae

(pressure is uniform in both cross-sections and depends only upon longitudinal distance)

- fluid is incompressible and viscosity negligible

Geometry

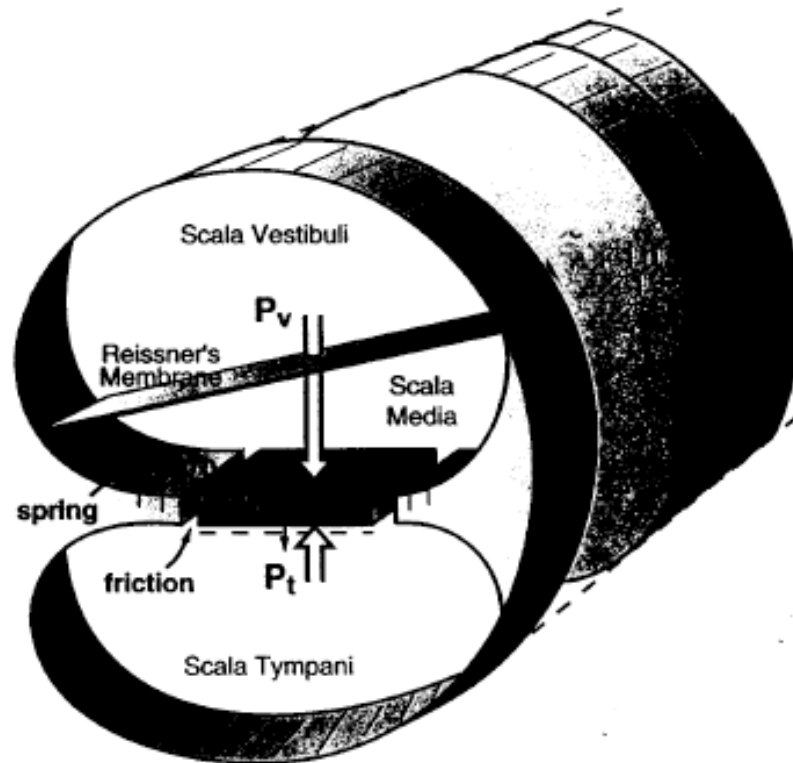

x - longitudinal distance along cochlea

b and h - width and height of the scalae (assumed constant for now)

d - vertical (transverse) displacement of the BM

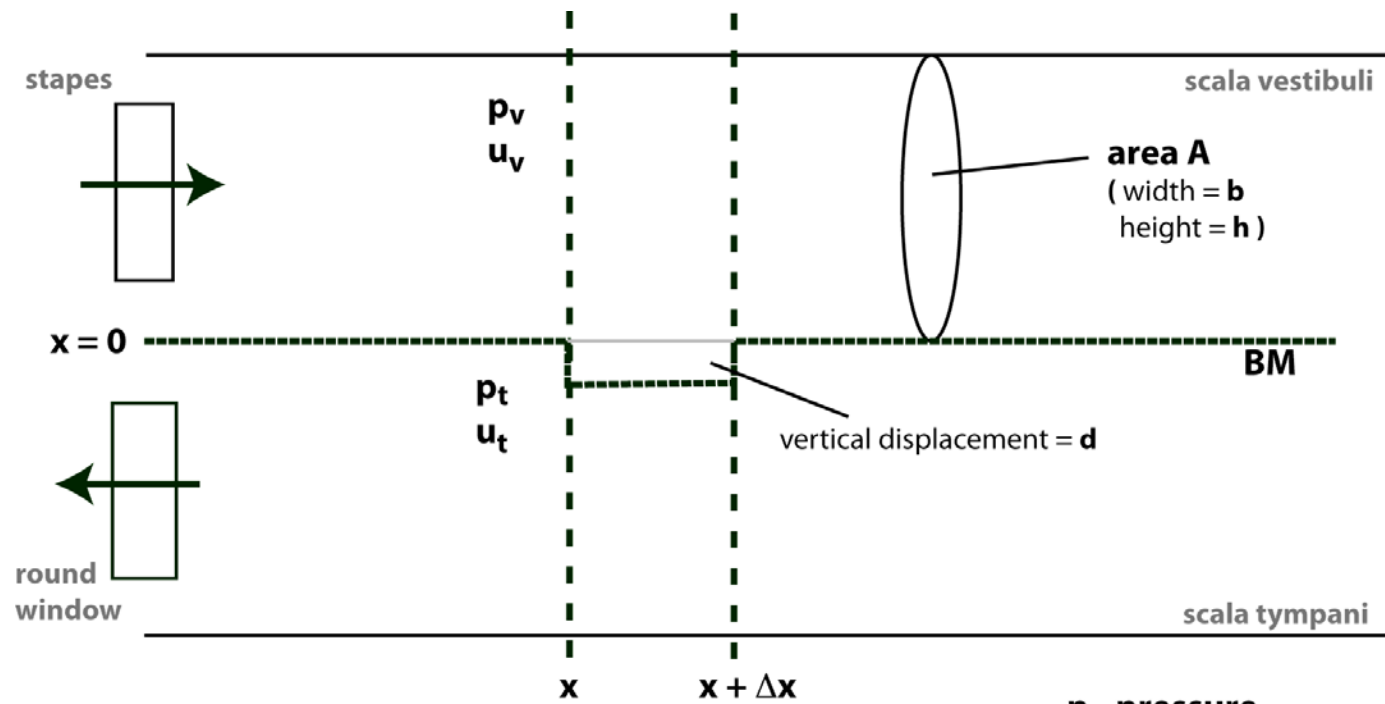

p - pressure
u - fluid velocity
 ρ - fluid density

Fluid Flow Due to Pressure Difference

Consider element of scala vestibuli. Using Newton's 2nd law (no fluid viscosity):

$$\Delta t \cdot A_v \cdot [p_v(x, t) - p_v(x + \Delta x, t)] = \rho \cdot \Delta x \cdot A_v \cdot [u_v(x, t + \Delta t) - u_v(x, t)]$$

$$\frac{\partial p_v}{\partial x} = -\rho \frac{\partial u_v}{\partial t}$$

$$\frac{\partial p_t}{\partial x} = -\rho \frac{\partial u_t}{\partial t}$$

Fluid Velocity to Membrane Displacement

From the conservation of mass (incompressible fluid):

$$\Delta t \cdot A_v \cdot \rho \cdot [u(x, t) - u(x + \Delta x, t)] = \Delta x \cdot \rho \cdot b \cdot [d(x, t + \Delta t) - d(x, t)]$$

$$A_v \frac{\partial u_v}{\partial x} = -b \frac{\partial d}{\partial t}$$

$$A_t \frac{\partial u_t}{\partial x} = b \frac{\partial d}{\partial t}$$

BM Motion Due to Pressure Difference

Consider all forces acting on the BM:

$$F = F_{stiffness} + F_{drag} + F_{pressure} = \mu \cdot \Delta x \cdot \frac{\delta^2 d}{\delta t^2}$$

$$\mathbf{b} \cdot [\mathbf{p}_v(\mathbf{x}, \mathbf{t}) - \mathbf{p}_t(\mathbf{x}, \mathbf{t})] = \mu \cdot \frac{\delta^2 \mathbf{d}(\mathbf{x}, \mathbf{t})}{\delta \mathbf{t}^2} + \alpha \cdot \frac{\delta \mathbf{d}(\mathbf{x}, \mathbf{t})}{\delta \mathbf{t}} + \kappa \cdot \mathbf{d}(\mathbf{x}, \mathbf{t})$$

Some consequences

$$u_v(x, t) = -u_t(x, t)$$

$$p_v(x, t) + p_t(x, t) = \alpha$$

Simplifications

$$\underline{\text{Let:}} \quad p \equiv p_v - p_t \qquad u \equiv A_{cs}(u_v - u_t)/2$$

Assume both u and p are in sinusoidal steady-state (stimulus frequency ω) such that:

$$\mathbf{p}(\mathbf{x}, t) = \Re[\mathbf{P}(\mathbf{x}, \omega)e^{j\omega t}] \qquad \mathbf{u}(\mathbf{x}, t) = \Re[\mathbf{U}(\mathbf{x}, \omega)e^{j\omega t}]$$

$$\Rightarrow \frac{\partial \mathbf{P}}{\partial \mathbf{x}} = -\frac{2\rho}{A_{cs}} i\omega \mathbf{U} = -\mathbf{Z}\mathbf{U}$$

(eqn. 1)

Simplifications II

$$\frac{\partial p}{\partial x} = \frac{A_{cs}}{2} \left[-\frac{b}{A_{cs}} \left(\frac{\partial d}{\partial t} + \frac{\partial d}{\partial t} \right) \right] = -b \frac{\partial d}{\partial t}$$

$$d(t) = \int -\frac{e^{j\omega t}}{b} \frac{\partial U}{\partial x} dt = -\frac{e^{j\omega t}}{j\omega b} \frac{\partial U}{\partial x}$$

Plugging back into the equation of motion (relating pressure and displacement):

$$\frac{\partial U}{\partial x} = -\frac{P}{j\omega \frac{\mu}{b^2} + \frac{\alpha}{b^2} + \frac{1}{j\omega \frac{b^2}{\kappa}}} = -Y P$$

(eqn. II)

Wave Equation

$$\frac{\partial \mathbf{P}}{\partial \mathbf{x}} = -\frac{2\rho}{\mathbf{A}_{\text{cs}}} \mathbf{i}\omega \mathbf{U} = -\mathbf{Z}\mathbf{U}$$

$$\frac{\partial \mathbf{U}}{\partial \mathbf{x}} = -\frac{\mathbf{P}}{\mathbf{j}\omega \frac{\mu}{\mathbf{b}^2} + \frac{\alpha}{\mathbf{b}^2} + \frac{1}{\mathbf{j}\omega \frac{\mathbf{b}^2}{\kappa}}} = -\mathbf{Y}\mathbf{P}$$

$$\frac{\partial^2 P}{\partial x^2} + \frac{1}{\ell^2} P = 0$$

$$\ell \equiv j\sqrt{1/ZY}$$

$$\frac{\partial^2 U}{\partial x^2} + \frac{1}{\ell^2} U = 0$$

$$p(x, t) = P_1 e^{i(x/\ell + \omega t)} + P_2 e^{i(-x/\ell + \omega t)}$$

Analogy to Electrical Transmission Line

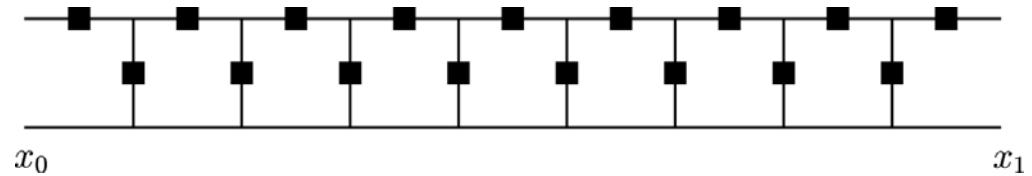
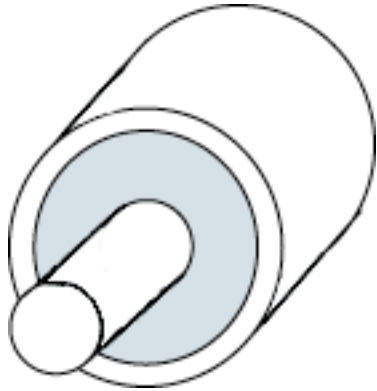

Electrical Case (loss-less)

$$-\frac{\partial v}{\partial x} = L \frac{\partial i}{\partial t}$$



$$-\frac{\partial i}{\partial x} = C \frac{\partial v}{\partial t}$$



Cochlear Case

$$\frac{\partial \mathbf{P}}{\partial \mathbf{x}} = -\mathbf{Z}\mathbf{U}$$

$$\frac{\partial \mathbf{U}}{\partial \mathbf{x}} = -\mathbf{Y}\mathbf{P}$$

Assumptions Revisited

b, A not constant



$$Z \longrightarrow Z(x)$$

$$Y \longrightarrow Y(x)$$

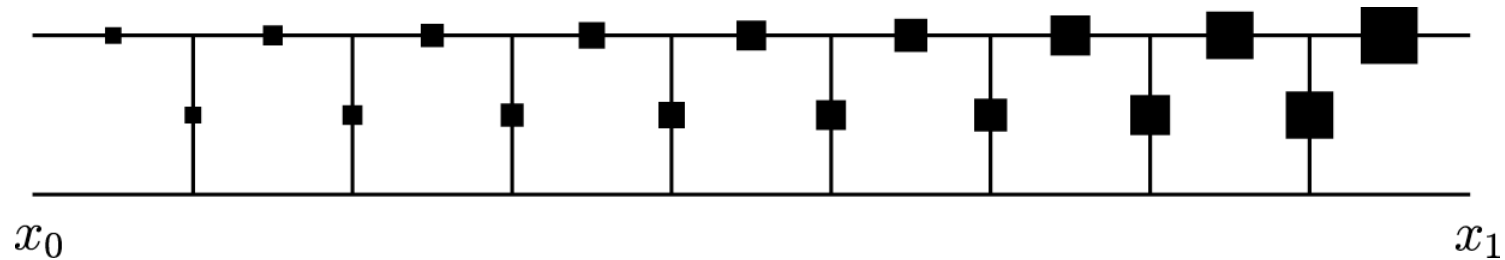

\Rightarrow non-uniform transmission line

WKB Approximation

Wentzel, Kramers and Brillouin (1926)

Particle with energy E moving in constant potential field V :

$$\psi(x) = Ae^{\pm jkx}$$

$$k \equiv \sqrt{2m(E - V)}/\hbar$$

⇒ What if V is not constant, but varies gradually?

$$\psi(x) \cong \frac{C}{\sqrt{k(x)}} e^{\frac{j}{\hbar} \int k(x) dx}$$

$$k(x) \equiv \sqrt{2m[E - V(x)]}/\hbar$$

WKB Applied to Cochlea

Assumption: Cochlear parameters (e.g. BM stiffness, scalae area) vary *gradually* such that cochlea behaves like a uniform transmission line *locally*

$$P(x, \omega) = A(x) e^{-j \int_0^x dx' / \ell(x', \omega)}$$

$$\ell(x, \omega) = j \left[\frac{j\omega L + R + 1/j\omega C}{j\omega M} \right]^{1/2} \quad \longrightarrow \quad \ell(x, \omega) = \frac{l}{4N} \frac{(1 - \beta^2 + j\delta\beta)^{1/2}}{\beta}$$

$$\omega_r(x) \equiv 1/\sqrt{LC} \quad \beta(x, \omega) \equiv \omega/\omega_r(x) \quad \delta \equiv \omega_r(x)RC \quad N \equiv (l/4)\sqrt{M/L}$$

Transfer Function

$$T(x, \omega) = \frac{\text{BM velocity}}{\text{stapes velocity}}$$

$$\text{BM velocity} = \frac{e^{j\omega t}}{b} \ell^2(x, \omega) Y e^{-j \int_0^x dx' / \ell(x', \omega)}$$

$$\omega_r(x) = \omega_{max} e^{-x/l}$$

WKB Applied to Cochlea (cont.)

$$\beta = \omega / \omega_r \qquad dx = \ell \frac{d\beta}{\beta}$$

$$\longrightarrow 4N \int_0^x \frac{d\beta}{[1 - \beta^2 + j\delta\beta]^{1/2}}$$

$$\mathbf{T}(\mathbf{x}, \omega) \approx \mathbf{T}_0 \mathbf{j}\beta(\mathbf{x}, \omega) \left[\frac{\omega_{\max}}{\omega_r(\mathbf{x})} \right] \frac{e^{j4N\{\sin^{-1}[\beta(\mathbf{x}, \omega) - j\delta/2] - \sin^{-1}[\beta(0, \omega) - j\delta/2]\}}}{[1 - \beta^2(\mathbf{x}, \omega) + j\delta\beta(\mathbf{x}, \omega)]^{3/4}}$$

Comparison to Data

Physiological measurements of BM motion relative to stapes displacement

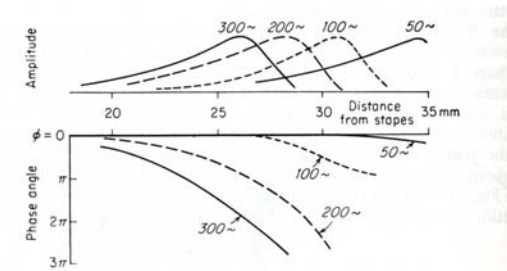
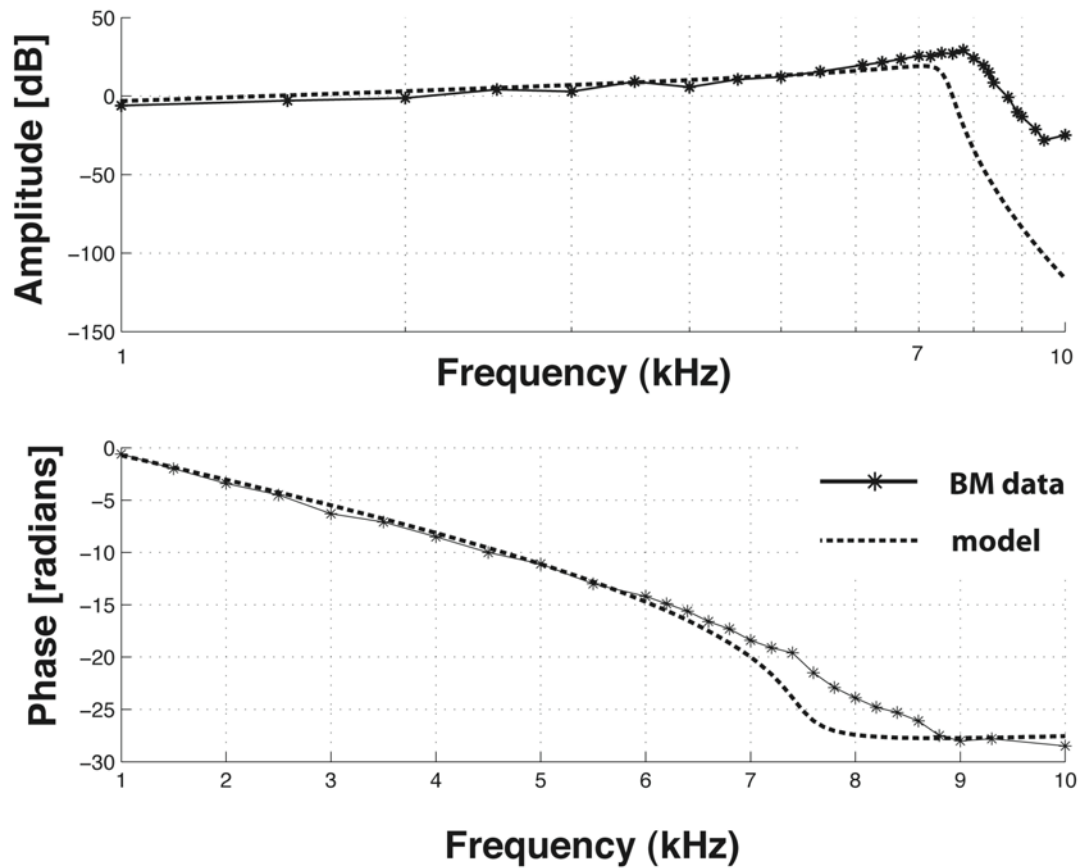
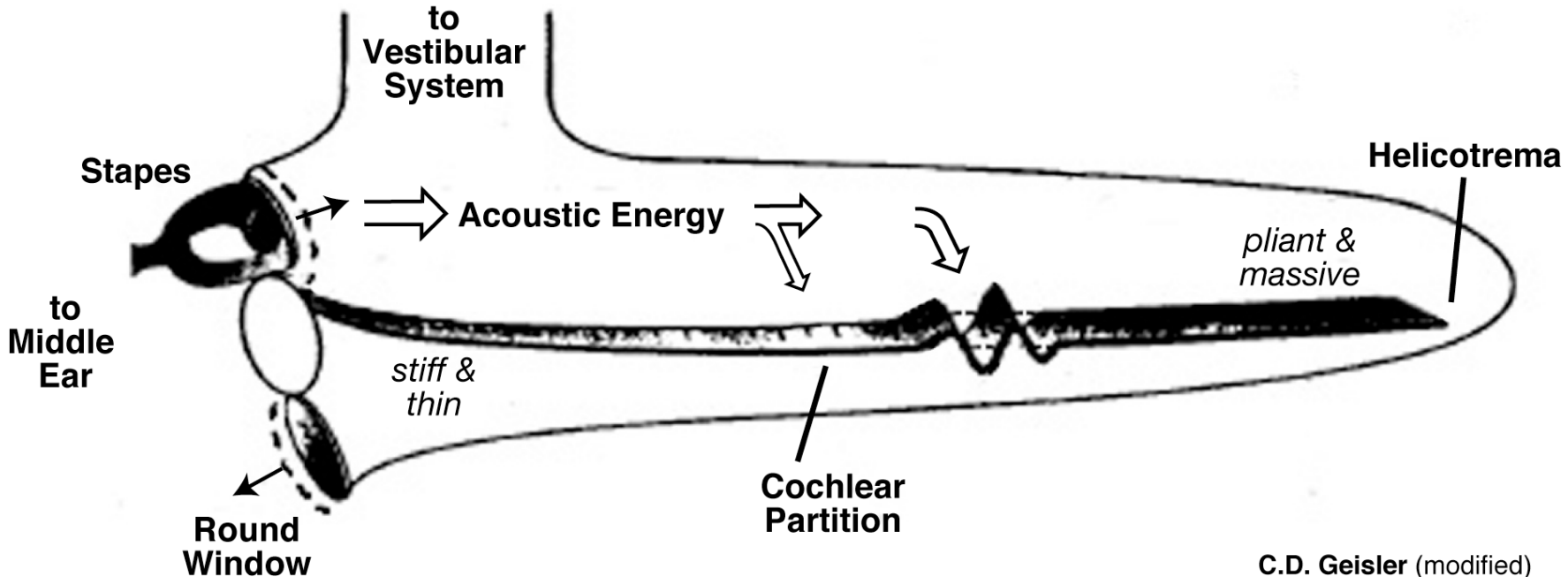

FIG. 11-58. Phase displacement and resonance curves for four low tones.

[Rhode, 1971]

Mammalian Cochlea Uncoiled



C.D. Geisler (modified)

Model provides a starting point for thinking about cochlear dynamics

⇒ What features are present in a real ear that we would like the model to capture?

I. Near Threshold in Viable Ears

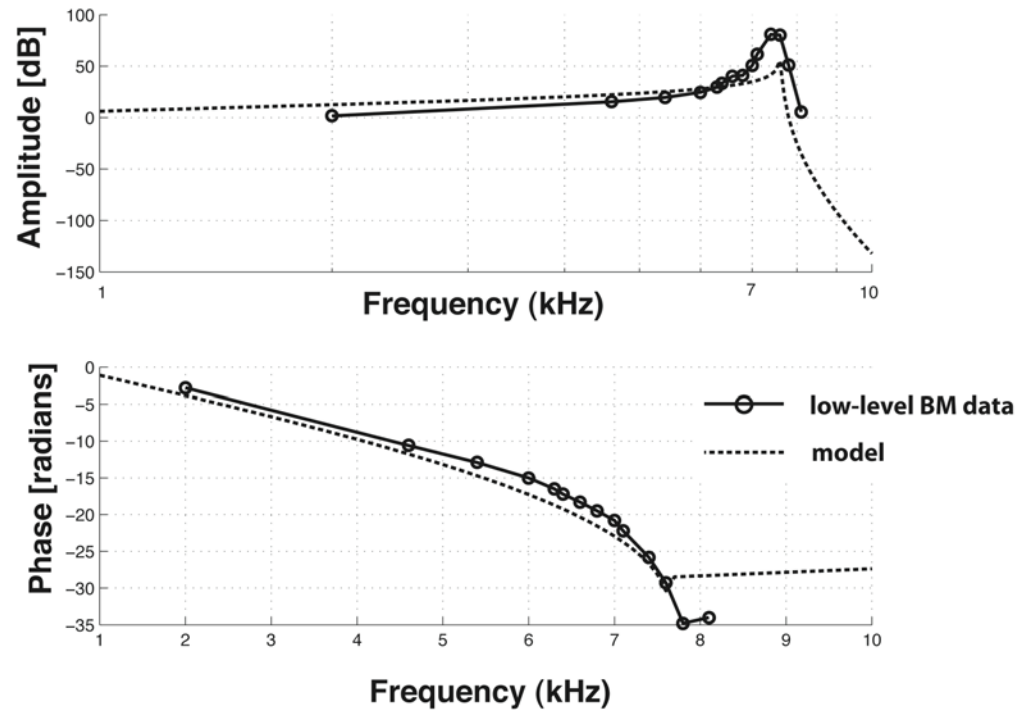

[Rhode, 1971
Zweig, 1991]

Model can not capture sharp tuning/large group delay at CF

⇒ **Need for active mechanisms?** [Neely and Kim, 1983]

II. Nonlinearity

Compressive BM Growth (on CF)

BM response at a fixed spot to different frequency tones

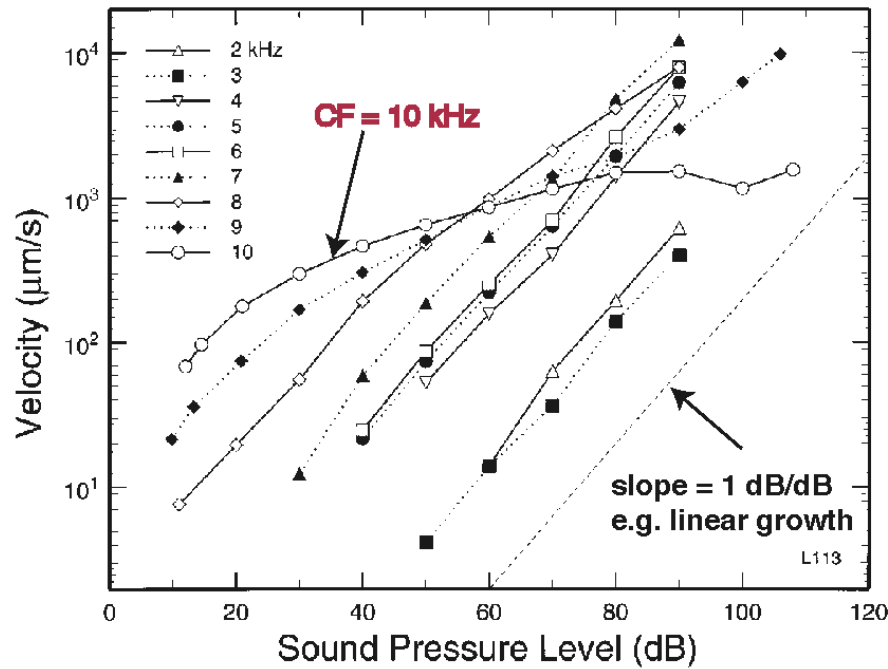

from Ruggero et al. (JASA, 1997)

Two-tone Distortion in Pressure

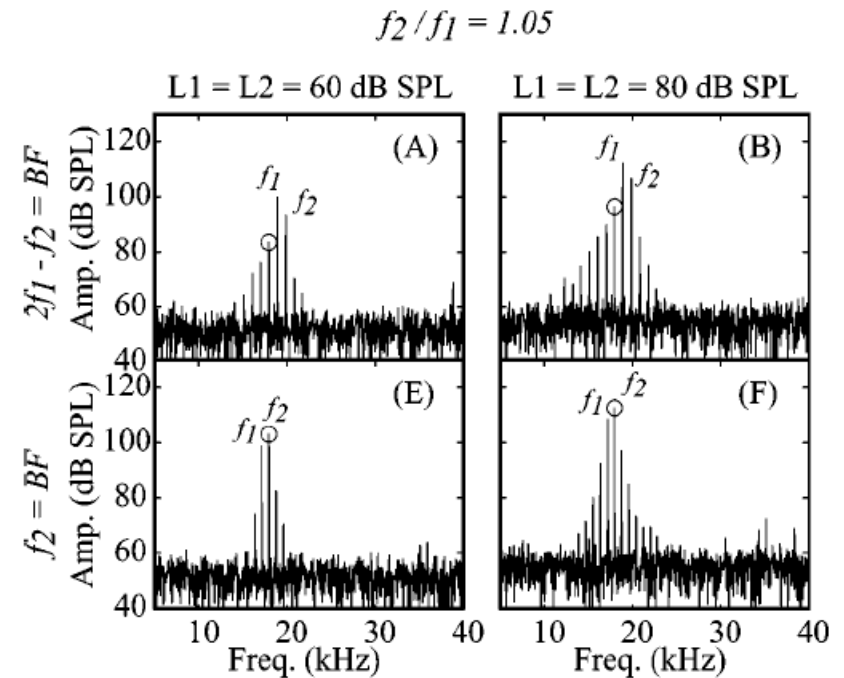

Dong and Olson (JASA, 2005)

\Rightarrow Source of nonlinearity?

III. OAEs

Otoacoustic Emissions (OAEs)

sounds emitted by a normal, healthy ear

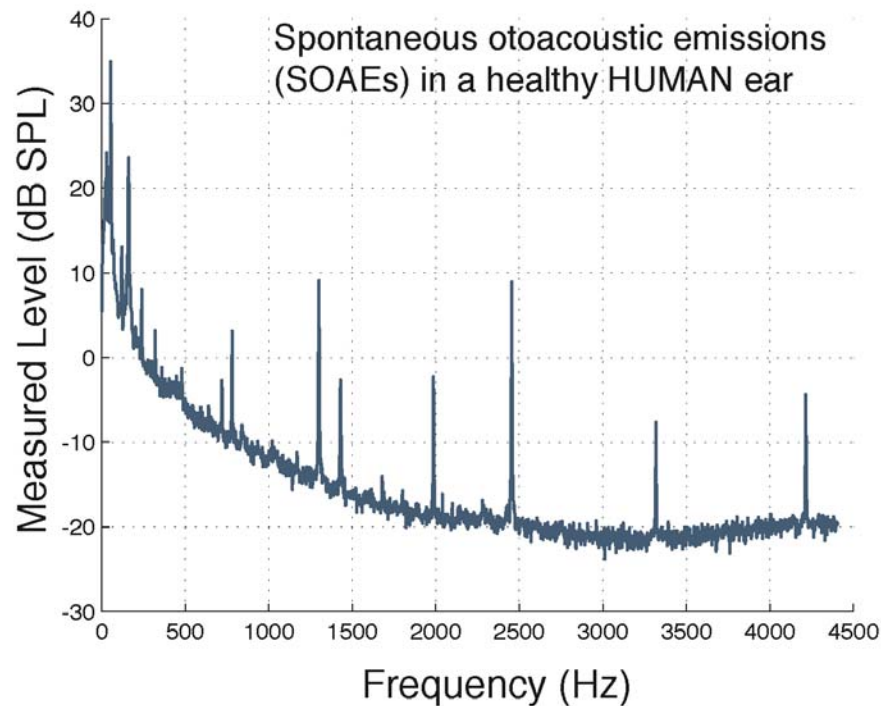

spontaneous or evoked

⇒ Model could serve to elucidate OAE generation

III. OAEs (cont.)

Reflection of energy?

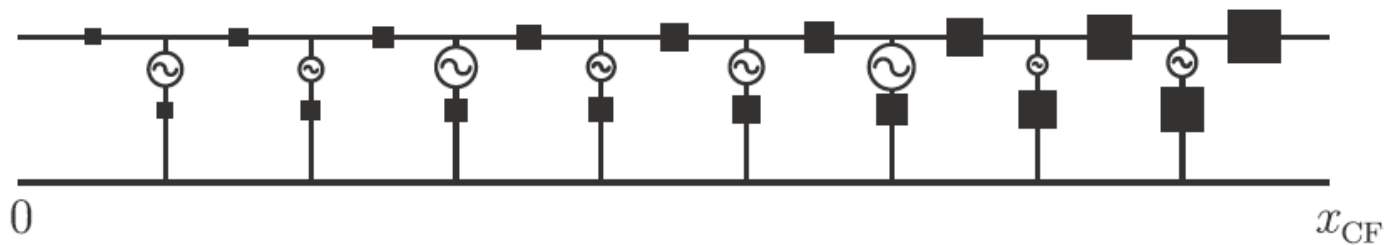
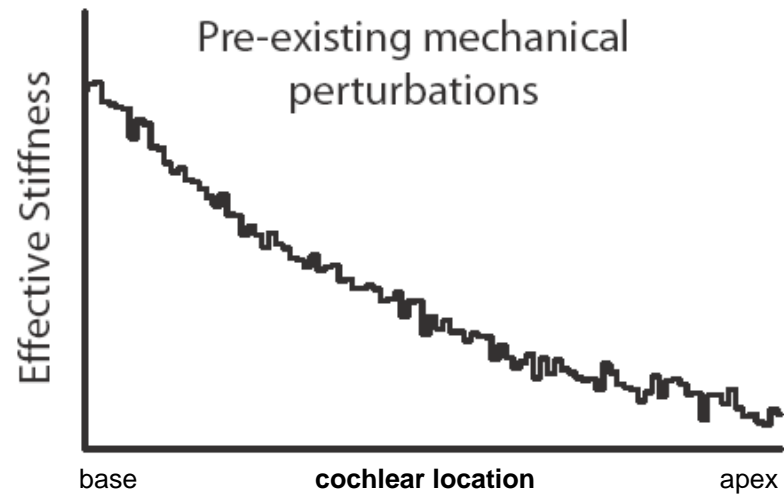

Transmission line with random irregular 'sources'

Summary

Developed a passive, linear 1-D transmission line model for the cochlea

Simple model captures essential features of the cochlea and can serve as a foundation for more realistic iterations

Ultimate goal is to use cochlear models to better understand auditory function/physiology and potential clinical applications



Georg von Békésy (1899-1972)

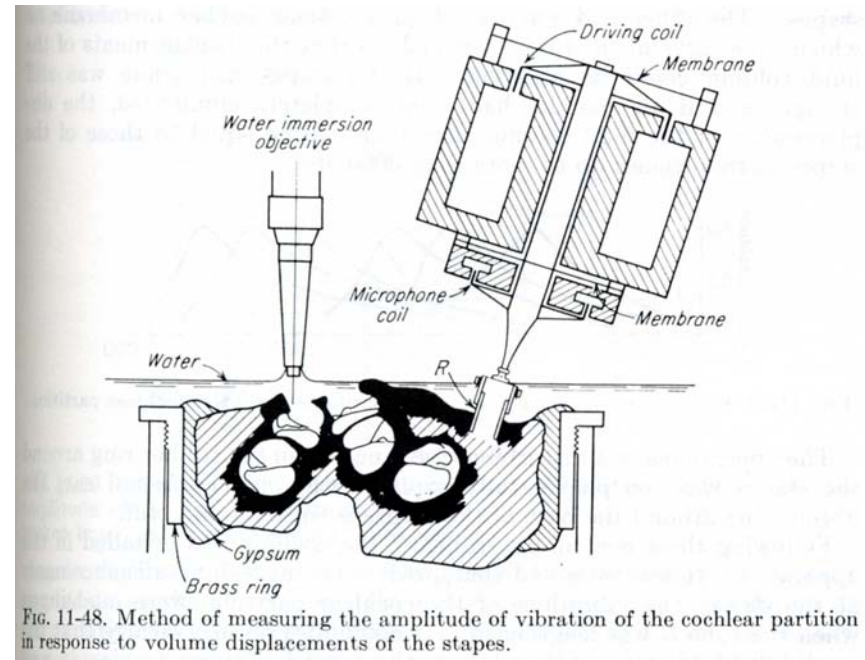

FIG. 11-48. Method of measuring the amplitude of vibration of the cochlear partition in response to volume displacements of the stapes.