

Electromechanical deflections of piezoelectric tubes with quartered electrodes

C. Julian Chen

IBM Thomas J. Watson Research Center, P. O. Box 218, Yorktown Heights, New York 10598

(Received 16 July 1991; accepted for publication 4 November 1991)

The deflection of a piezoelectric tube, with the outer (or inner) metal coating sectioned into four quadrants, is analyzed. We show that by applying a voltage V on one of the quadrants, the electromechanical deflection is $(\sqrt{2}d_{31}VL^2/\pi Dh)$, where d_{31} is the piezoelectric coefficient, L is the length, D the diameter, and h the wall thickness of the tube. The deflections calculated with it agree well with the results of finite-element calculations and direct experimental measurements. The formula can be used in the design and application of tube scanners in scanning tunneling microscopes and scanning force microscopes.

The tube scanner was invented by Binnig and Smith in 1986.¹ It soon became the predominant design of piezoelectric scanner used in scanning tunneling microscopy (STM) and scanning force microscopy (SFM). A single PZT tube, with the outer (or inner) metal coating sectioned into four quadrants, with voltages applied on, can generate displacements in three dimensions. Its advantages over the tripod scanner are prevailing: higher electromechanical constant, higher resonance frequency, and much smaller size, which greatly simplifies vibration isolation.

The understanding of the basic physics and performance of tube scanners is crucial to its design and application. Several authors have contributed to this scientific problem.²⁻⁴ The treatment of the z displacement is straightforward.³ For a piezoelectric tube of length L , wall thickness h , upon application of the voltage V , the z displacement is $d_{31}VL/h$. Here, d_{31} is a relevant piezoelectric coefficient which is given in the product catalog.⁵ The analysis of the x and y displacement is not that straightforward. Using finite-element analysis, Carr² obtained the x deflections of tube scanners of 13 different dimensions. These values agree well with measurements. However, from both conceptual and practical point of view, analytic formulas stemming from valid theoretical reasonings, if accurate enough, are preferred. Locatelli and Lamboley³ provided a rough estimation based on a simple analysis: For the case of applying opposite voltages to opposite electrodes, the x displacement is amplified by the ratio of the length L and the radius r of the tube over the z displacement. For the case of a single applied voltage on one of the quadrants, Tiedje and Brown⁴ proposed that the amplification factor should be $L/2r$. However, those estimations are 7%–16% larger than the values obtained from finite-element calculations and direct measurements.²

In this letter, we present an analysis of the x and y deflections of the tube scanner using standard methods in the theory of elasticity,⁶ following the classical treatment of bimorph⁷ by Curie.⁸ We also provide a series of direct measurements of the deflections using a precision measuring machine,^{9,10} with $\pm 0.01 \mu\text{m}$ accuracy. The values of deflections calculated from these formulas agree well with the results of finite-element analysis² and our direct measurements. Those formulas can be effectively used in the

design and application of the tube scanners in STM and SFM.

First, we present a treatment of the deflection of a piezoelectric tube with quartered electrodes in the symmetric-voltage mode. To simplify mathematics, we assume that the wall thickness of the piezoelectrics is much smaller than the diameter. Therefore, the variation of strain and stress over the wall thickness can be neglected. As shown in Fig. 1, two voltages, equal in magnitude and opposite in sign, are applied on the two y quadrants. The inner metal coating and the two x quadrants are grounded. Immediately after the onset of y voltages, a strain in the z direction, $S_3=d_{31}V/h$, is generated. It in turn creates a stress $\sigma_3 = YS_3$ in the z direction, where Y is Young's modulus. The torque of this pair of forces causes the tube to bend. The bending of the tube generates a torque in the opposite direction. At equilibrium, the total torque in any cross section should be zero. In virtue of the symmetry of the problem, it is sufficient to consider one quarter of the circle. Assuming that the stress generated by the bending is linear with respect to y , the total stress $\sigma(\theta)$ in the piezoelectrics, as a function of the angle θ , is

$$\begin{aligned} 0 < \theta < \pi/4, \quad \sigma(\theta) &= -\alpha \sin \theta, \\ \pi/4 < \theta < \pi/2, \quad \sigma(\theta) &= \sigma_3 - \alpha \sin \theta. \end{aligned} \quad (1)$$

The constant α is to be determined by the condition of zero torque. The torque can be evaluated easily by integrating over the angle θ (see Fig. 1). The condition of zero torque is

$$\begin{aligned} \int_0^{\pi/4} (-\alpha \sin \theta) \sin \theta d\theta \\ + \int_{\pi/4}^{\pi/2} (\sigma_3 - \alpha \sin \theta) \sin \theta d\theta = 0, \end{aligned} \quad (2)$$

which gives

$$\alpha = 2\sqrt{2}\sigma_3/\pi. \quad (3)$$

The neutral plane, where the stress is zero, lies *beyond the periphery of the tube*:

$$y_0 = \pi D/4 \sqrt{2} \approx 0.555D, \quad (4)$$

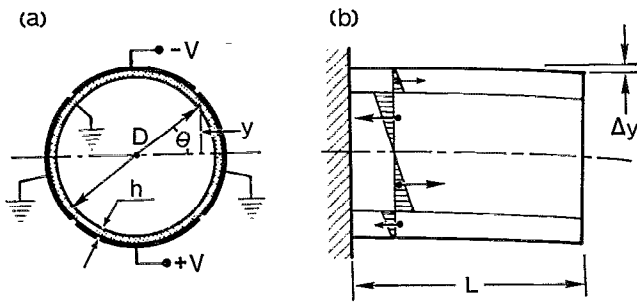

FIG. 1. Deflection of a tube scanner in the bipolar arrangement. (a) Opposite and equal voltages are applied on the y quadrants of a tube scanner. The x quadrants and the inner metal coating are grounded. A positive stress (pressure) is generated in the upper quadrant, and a negative stress (tension) is generated in the lower quadrant. (b) At equilibrium a distribution of stress and strain is established such that the total torque at each cross section is zero. This condition determines the deflection of the tube scanner in the y direction.

which is 11% larger than the radius r . This explains the systematic error in previous estimations.^{3,4} Using elementary geometry, we find the curvature of bending:

$$R = \pi Dh / 4 \sqrt{2} d_{31} V. \quad (5)$$

Again, using elementary geometry, the deflection is found to be

$$\Delta y = L^2 / 2R = 2 \sqrt{2} d_{31} V L^2 / \pi Dh. \quad (6)$$

It is convenient to define a *piezo constant* as

$$K_y \equiv dy / dV = 2 \sqrt{2} d_{31} L^2 / \pi Dh. \quad (7)$$

The formula for the x deflection is identical.

In the original design of Binnig and Smith,¹ the deflection voltage is applied only on one of the four quadrants. The stress is no more antisymmetric with respect to the $y=0$ plane, as shown in Fig. 2. The general form of the stress should have an additional term:

$$\begin{aligned} 0 < \theta < \pi/4, \quad \sigma(\theta) &= -\beta - \alpha \sin \theta, \\ \pi/4 < \theta < \pi/2, \quad \sigma(\theta) &= \sigma_3 - \beta - \alpha \sin \theta. \end{aligned} \quad (8)$$

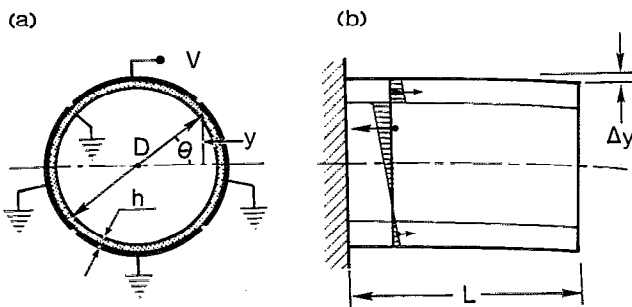

FIG. 2. Deflection of a tube scanner in the unipolar arrangement. (a) A voltage is applied on only one quadrant of the outer metal coating. All other quadrants and the inner metal coating are grounded. (b) At equilibrium, a distribution of stress and strain is established such that the total force and torque at each cross section is zero. This condition determines the y displacement.

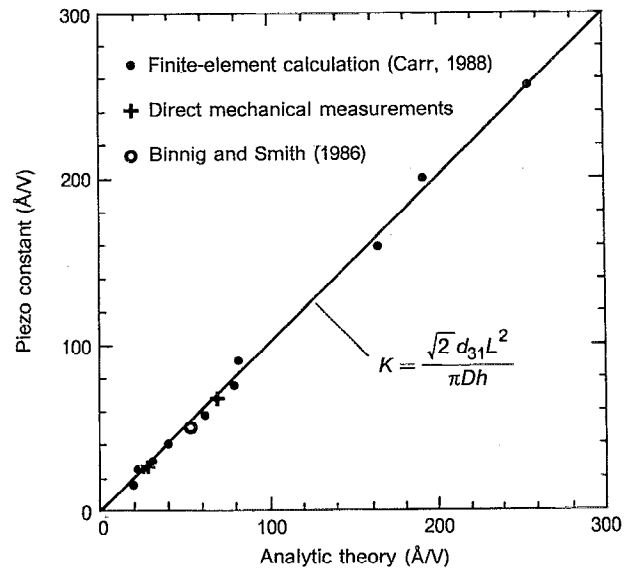

FIG. 3. Comparison of Eq. (11) with the results of finite-element calculation by Carr (Ref. 3) and direct measurements (see text). The measurement of Binnig and Smith, together with the calculation based on their dimensions using Eq. (11), is also marked.

The two constants are determined by two independent conditions: The total force on any plane to be zero, and the total torque on any plane to be zero. Similar calculation gives

$$\beta = \sigma_3 / 4 \quad (9)$$

and

$$\alpha = \sqrt{2} \sigma_3 / \pi. \quad (10)$$

Using similar arguments based on elementary geometry, we find

$$K_x = K_y = \sqrt{2} d_{31} L^2 / \pi Dh. \quad (11)$$

It is not surprising that the deflection by applying one voltage on a single quadrant, Eq. (11), exactly equals one half of the deflection by applying two equal and opposite voltages on two opposite quadrants, Eq. (7). It is simply a consequence of symmetry.

Figure 3 shows a comparison of Eq. (11) with the results of finite-element calculations by Carr² for the 11 cases using PZT-5H. The piezoelectric coefficient⁵ of PZT-5H is $d_{31} = -2.74 \text{ \AA/V}$. The average deviation between the finite-element calculations² and the predictions of Eq. (11) is found to be

$$\delta = \frac{1}{n} \left(\sum (K_{\text{fini}} - K_{\text{anal}}) \right) \approx -0.76 \text{ \AA/V}, \quad (12)$$

where K_{fini} and K_{anal} are the piezo constants from finite-element calculations² and the analytic treatment, Eq. (11), respectively. The root-mean-square error is

$$\sigma = \left(\sum [(K_{\text{fini}} - K_{\text{anal}})]^2 / n \right)^{1/2} \approx 4.5 \text{ \AA/V}. \quad (13)$$

Comparing with the absolute values, 20–260 \AA/V , the agreement can be considered excellent. The better-than-

TABLE I. Piezo constants K of PZT tubes with quartered electrodes: A comparison of theory, Eq. (7), with direct measurements.

Material	Diameter (mm)	Wall (mm)	Length (mm)	Theoretical K ($\text{\AA}/\text{V}$)	Measured K ($\text{\AA}/\text{V}$)
PZT-5H	12.7	1.02	12.7	30.7	28
PZT-5H	12.7	1.02	19.05	69.2	66
PZT-5H	12.7	1.02	43.2	356	340

expected accuracy is probably due to the cancellation of two factors considered by Carr,² i.e., the finite thickness of the tube and the existence of the metal coating. Since the standard tolerances of the piezoelectric coefficient of PZT are $\pm 20\%$ of its typical values,⁵ Eqs. (7) and (11) are sufficiently accurate.

Table I shows results of direct measurements of the y deflections of three PZT tubes, provided by EBL.¹¹ The measurement was made with a Universal Measuring Machine,⁹ with an inductive position transducer and an analog amplifier.¹⁰ Each division on this measuring machine corresponds to 0.000 005 in., or 0.127 μm . The least significant digit is about 0.01 μm . To improve accuracy, the measurement was made with the bipolar mode. Different voltages up to ± 300 V are applied on both sides for several times. The deflections are measured and averaged. As seen, the agreement is good. The data point of Binnig and Smith¹ is also marked on Fig. 3.

To summarize, using methods in the theory of elasticity, we analyzed the electromechanical deflection of a piezoelectric tube, with the outer (or inner) metal coating sectioned into four quadrants. We obtained analytic expressions of the x , y deflections. The values calculated by them agree well with the results of finite-element calculations and direct experimental measurements. These formulas can be used in the design and calibration of STM and SFM with tube scanners.

The author wishes to thank D. A. Smith for discussions and R. Ruggiero for setting up the Universal Measuring Machine.

¹G. Binnig and D. P. E. Smith, *Rev. Sci. Instrum.* **57**, 1688 (1986).

²R. G. Carr, *J. Microsc.* **152**, Pt. 2, 379 (1988).

³M. Locatelli and G. Lambole, *Rev. Sci. Instrum.* **59**, 661 (1988).

⁴T. Tiedje and A. Brown, *J. Appl. Phys.* **68**, 649 (1990).

⁵Vernitron Bulletin 9247-2, Morgan Matroc Inc., Vernitron Piezoelectric Division, Bedford, OH 44146 (1979).

⁶L. D. Landau and E. M. Lifshitz, *Theory of Elasticity* (Pergamon, Oxford, 1986).

⁷Bimorph is a trade name of Morgan Matroc, Inc., Vernitron Piezoelectric Division (Bedford, OH 44146) for the flexing-type piezoelectric element. It becomes a standard term in the literature. Historically, such a flexing-type piezoelectric element was developed and analyzed by Curie in the 1880's. See J. Curie, *J. Phys. (Paris)* **8**, 149 (1889).

⁸J. Curie, *J. Phys. (Paris)* **8**, 149 (1889).

⁹Universal Measuring Machine Model No. 3, Moore Tool Co. Inc., Bridgeport, CT 06108.

¹⁰Esterline Corp/Federal Products Corp., Providence, RI 02940.

¹¹EBL Division, Staveley Sensors Inc., East Hartford, CT 06108.