



# Conic relaxations of the unit commitment problem



Salar Fattahi, Morteza Ashraphijuo, Javad Lavaei\*, Alper Atamtürk

Department of Industrial Engineering and Operations Research, University of California, Berkeley, CA 94720-1777, USA

## ARTICLE INFO

### Article history:

Received 30 October 2016

Received in revised form

18 May 2017

Accepted 12 June 2017

Available online 14 June 2017

### Keywords:

Power systems

Unit commitment

Global minimum

Convex optimization

Valid inequalities

Convex-hull pricing

## ABSTRACT

The unit commitment (UC) problem aims to find an optimal schedule of generating units subject to demand and operating constraints for an electricity grid. The majority of existing algorithms for the UC problem rely on solving a series of convex relaxations by means of branch-and-bound and cutting-planning methods. The objective of this paper is to obtain a convex model of polynomial size for practical instances of the UC problem. To this end, we develop a convex conic relaxation of the UC problem, referred to as a strengthened semidefinite program (SDP) relaxation. This approach is based on first deriving certain valid quadratic constraints and then relaxing them to linear matrix inequalities. These valid inequalities are obtained by the multiplication of the linear constraints of the UC problem, such as the flow constraints of two different lines. The performance of the proposed convex relaxation is evaluated on several hard instances of the UC problem. For most of the instances, globally optimal integer solutions are obtained by solving a single convex problem. For the cases where the strengthened SDP does not give rise to a global integer solution, we incorporate other valid inequalities. The major benefit of the proposed method compared to the existing techniques is threefold: (i) the proposed formulation is a single convex model with polynomial size and, hence, its global minimum can be found efficiently using well-established first- and second-order methods by starting from any arbitrary initial state, (ii) unlike heuristic methods and local-search algorithms that return local minima whose closeness to a global solution cannot be measured efficiently, the proposed formulation aims at obtaining global minima, (iii) the proposed convex model can be used in convex-hull pricing to minimize uplift payments made to generating units in energy markets. The proposed technique is extensively tested on IEEE 9-bus, IEEE 14-bus, IEEE 30-bus, IEEE 57-bus, IEEE 118-bus, and IEEE 300-bus systems with different settings and over various time horizons.

© 2017 Elsevier Ltd. All rights reserved.

## 1. Introduction

The unit commitment (UC) problem is concerned with finding an optimal schedule of generating units in a power system, by minimizing the operational cost of power generators subject to forecasted energy demand and operating constraints. The operating constraints include physical limits and security constraints. In a mixed-integer programming (MIP) formulation of the UC problem, discrete variables model the on/off status of each generator and the continuous variables account for the amount of production for each generator. The objective function captures the fuel and the start-up/shut-down costs of generating units. The UC problem is

hard due to its nonconvex nature and its large instances are computationally challenging to solve [1].

### 1.1. Related works

The UC problem has a vital role in the operation of electricity grids and been studied extensively [2]. The existing optimization techniques for UC include Lagrangian relaxation (LR) methods, branch-and-bound (BB) methods, dynamic programming (DP) methods, simulated-annealing (SA) methods, and cutting-plane methods [3]. The LR method provides an approximation for the optimal value of an intractable optimization problem by solving a simpler problem. Ongsakul et al. [4] propose an enhanced adaptive LR method by defining new decision variables. Dubost et al. [5] use the solution of a dual relaxation of the UC problem in a primal proximal-based heuristic method to attain a solution. Primal and dual solution methods for the UC problem in hydro-thermal power

\* Corresponding author.

E-mail addresses: [fattahi@berkeley.edu](mailto:fattahi@berkeley.edu) (S. Fattahi), [ashraphijuo@berkeley.edu](mailto:ashraphijuo@berkeley.edu) (M. Ashraphijuo), [lavaei@berkeley.edu](mailto:lavaei@berkeley.edu) (J. Lavaei), [atamturk@berkeley.edu](mailto:atamturk@berkeley.edu) (A. Atamtürk).

<b>Nomenclature</b>	
<i>Abbreviations</i>	
BB	Branch and Bound
ISO	Independent System Operator
MILP	Mixed-Integer Linear Programming
PTDF	Power Transfer Distribution Factor
QP	Quadratic Programming
SA	Simulated-Annealing
UC	Unit Commitment
DP	Dynamic Programming
LR	Lagrangian Relaxation
MIP	Mixed-Integer Programming
QCQP	Quadratically-Constrained Quadratic Programming
RLT	Reformulation-Linearization Technique
SDP	Semidefinite Programming
VUB	Variable Upper Bound
<i>Constants</i>	
$\mathbf{C}_g$	Bus-to-generator incidence matrix
$\mathbf{f}_{\max}$	Maximum flow vector for lines
$\mathbf{M}$	Matrix collecting the coefficients of linear constraints
$\mathbf{p}_{\max}$	Vector of upper bounds on the generation of generators
$n_b$	Number of buses
$n_l$	Number of lines
$r_i$	Maximum difference between the generations at two adjacent time slots for generator $i$
$\mathbf{u}$	Vector of reliable upper bounds
$a_i$	Coefficient of the quadratic term in the cost function of generator $i$
$c_{i,\text{fixed}}$	Fixed cost of generator $i$
$D_i$	Minimum up-time of generator $i$
$\mathbf{d}_t$	Vector of demands at time $t$
$\mathbf{H}$	Shift factor matrix
$\mathbf{m}$	Vector collecting the constant terms of linear constraints
$\mathbf{p}_{\min}$	Vector of lower bounds on the generation of generators
$n_g$	Number of generators
$t_0 + 1$	Terminal time
$s_i$	Maximum amount of generation for the start-up and shut-down of generator $i$
$\mathbf{l}$	Vector of reliable lower bounds
$b_i$	Coefficient of the linear term in the cost function of generator $i$
$c_{i,\text{start}}$	Start-up or shut-down cost of generator $i$
<i>Functions</i>	
$c(\cdot)$	Total cost of UC problem
$g_{i,t}(\cdot)$	Power generation cost for generator $i$ at time $t$
$c_r(\cdot)$	Objective function of SDP and Strengthened SDP relaxations
$h_{i,t}(\cdot)$	Start-up or shut-down cost for generator $i$ at time $t$
<i>Indices, numbers, and sets</i>	
$\mathbf{X}^{ij}$	$(i,j)^{\text{th}}$ entry of a matrix $\mathbf{X}$
$\mathbf{x}^i$	$i^{\text{th}}$ entry of a vector $\mathbf{x}$
$\mathcal{T}$	Set corresponding to $\{0, 1, \dots, t_0 + 1\}$
$\overline{\mathcal{T}}_0$	Set corresponding to $\{0, 1, \dots, t_0\}$
$\mathbb{R}$	Set of real numbers
$\mathcal{B}$	Set of bus indices
$\mathcal{G}$	Set of generator indices
$\mathbf{X}_{ij}$	$(i,j)^{\text{th}}$ entry of a matrix $\mathbf{X}$
$\mathbf{x}_i$	$i^{\text{th}}$ entry of a vector $\mathbf{x}$
$\overline{\mathcal{T}}$	Set corresponding to $\{1, 2, \dots, t_0\}$
$\mathcal{N}_l(i)$	Set of lines connected to line $l$
$\mathcal{S}^n$	Set of $n \times n$ real symmetric matrices
$\mathcal{L}$	Set of line indices
$\mathcal{G}^+$	Set of generator indices with positive reliable lower bound
<i>Variables</i>	
$\mathbf{x}_t$	Vector of all commitment statuses at time $t$
$\mathbf{w}$	Variable vector in SDP and Strengthened SDP relaxations
$\mathbf{p}_t$	Vector of all generator outputs at time $t \in \mathcal{T}$
$\mathbf{W}$	Variable matrix in SDP and Strengthened SDP relaxations

systems are studied by Gollmer et al. [6]. Moreover, Bai et al. [7] propose a decomposition procedure for solving the UC problem. Turgeon [8] designs an algorithm based on the BB method by recursively splitting the search space into smaller branches. Furthermore, Rajan et al. [9] propose a set of valid inequalities (turn on/off) instead of the simple minimum up- and down-time constraints to be able to solve hard cases of the UC problem by adopting a branch-and-cut technique.

A mixed-integer linear programming (MILP) UC reformulation was first proposed by Garver [10]. Morales-Espana et al. [11] provide new mixed-integer linear reformulations for start-up and shut-down constraints in the UC problem, which lead to tighter relaxations. O'Neill et al. [12] incorporate the transmission switching problem into the N-1 reliable UC problem and use a dual approach to solve the corresponding MILP. This method is extended by O'Neill et al. [13] to inter-regional planning and investment in a competitive environment. Furthermore, Ostrowski et al. [14] and Damci-Kurt et al. [15] propose classes of strong valid inequalities, including upper bounds for the generating powers as well as ramp-down and -up constraints, to provide smaller feasible operating

schedules for the generators. Muckstadt et al. [16] design a BB algorithm based on the LR method, which breaks down the UC problem into several simpler UC problems with one generator.

A two-stage stochastic program is introduced by Papavasiliou et al. [17] that takes into account the high penetration of wind power and system component failures. Ji et al. [18] and Liao [19] use a scenario generation technique and the chaotic quantum genetic algorithm to incorporate uncertainties of wind power. Lorca et al. [20] propose a multi-stage robust optimization-based model that accounts for stochastic non-anticipative load profiles. Other stochastic schemas are introduced by Cerisola et al. [21] and Philpott et al. [22] that model the revenue of a power company in the UC problem posed in electricity markets. These papers consider uncertainties that stem from different possible outcomes of spot markets. Furthermore, Nikzad et al. [23] and Yang et al. [24] introduce a stochastic security-constrained method to model the time-of-use program and wind power generation volatility, respectively. Another approach is taken by Ferruzzi et al. [25] that designs the optimal bidding strategy for micro grids considering the stochasticity in the used renewable energy in day-ahead

market by means of analog ensemble method.

More recently, a DP approach is used by Frangioni et al. [26] to solve a single-unit commitment problem with arbitrary convex cost functions. This work is an extension of the traditional MILP formulation of the UC problem but only considers one generator during the operating time horizon. The work by Madrigal et al. [27] proposes an interior-point/cutting-plane method to solve the UC problem, which attempts to amend a proposed set repeatedly to ultimately find the optimal solution by solving the problem over a tighter feasible set. Jabr [28] deploys a perspective reformulation of the unit commitment problem with quadratic cost function, which can be written as a second-order conic program. The paper introduces a tight polyhedral approximation to avoid using interior point methods for solving this nonlinear conic program.

Recently, we have experienced significant advances in using conic optimization for power optimization problems. Bai et al. [29] proposes a semidefinite programming (SDP) relaxation to solve the AC optimal power flow (OPF) problem. Lavaei et al. [30] show that the SDP relaxation is able to find a global minimum of OPF for a large class of practical systems, and Sojoudi et al. [31] discover that the success of this method is related to the underlying physics of power systems. Farivar et al. [32] and Lavaei et al. [33] offer different sufficient conditions under which the SDP relaxation of OPF provides zero duality gap. Tan et al. [34] reduce the complexity of the SDP relaxation for resistive networks by devising a distributed and computationally cheap algorithm. Moreover, Madani et al. [35] find an upper bound on the rank of the minimum rank solution of the SDP relaxation of the OPF problem, which is leveraged by Madani et al. [36] to find a near globally optimal solution of OPF via a penalized SDP technique in the case where the SDP relaxation fails to work. Chen et al. [37] propose a method based on the combination of SDP relaxation and branch-and-cut approaches together with strong valid inequalities to solve the OPF problem. Jozs et al. [38] design a hierarchy of SDP-based models to find a globally optimal solution of the OPF problem. Baradar et al. [39] and Bahrami et al. [40] propose conic and SDP relaxations of the OPF problem for integrated AC-DC systems, respectively. Moreover, the UC problem combined with AC OPF has been studied by Bai et al. [41] using the basic SDP relaxation and by Paredes et al. [42] via a SDP-based branch-and-bound technique.

The above-mentioned papers can be categorized into three groups: (i) methods based on a single convex model, (ii) methods based on a series of convex models, (iii) methods based on heuristics and local-search algorithms. Due to the complexity of the UC problem, these papers suffer from a number of issues:

- The existing methods relying on a single SDP formulation often fail to find a global minimum (as proven in this paper), unless the size of the convex model is allowed to be exponentially large.
- The existing methods relying on a series of convex problems do not guarantee the termination within an efficient time. This means that the number of iterations can grow exponentially for some practical instances of the problem.
- The existing methods based on heuristics or local-search algorithms produce a candidate solution without being able to measure its closeness to a global minimum.
- Although a global description of the feasible region of the UC problem is instrumental from both theoretical and practical perspectives, the existing methods do not offer a geometric analysis of the feasible region of the problem. For example, iterative methods use a sequence of convex relaxations of the original problem to gradually remove infeasible solutions from the convex relaxation, which depends on the given objective function and leads to a local description of the feasible region

(i.e., if the objective function changes, one may need to recalculate all the iterations to obtain a local description of the new part of the feasible region.)

The main objective of this paper is to develop a mathematical framework that addresses the above issues for practical instances of the UC problem. To this end, we design a single convex model of modest size that is able to find a global solution of the UC problem in many cases, which can also be used to study the convex-hull of the feasible set of this highly nonconvex problem.

In this paper, we consider the UC problem with a quadratic objective function and linear equality and inequality constraints with mixed-integer variables. This problem belongs to the larger set of polynomial optimization problems that is called quadratically-constrained quadratic programs (QCQPs). Different relaxation methods have been proposed in the literature to remedy the underlying nonconvexity of such problems. There are two main relaxations for QCQP, namely reformulation-linearization technique (RLT) and SDP relaxations. The RLT relaxation, introduced by Sherali et al. [43], is based on iteratively multiplying the linear constraints and substituting the resulted quadratic terms with new variables. In the SDP relaxation, the problem is first written as a rank-constrained optimization problem, and then the rank constraint carrying all the nonconvexity of the problem is relaxed into a conic constraint [44]. The exactness of this relaxation depends on the existence of a rank-1 optimal solution to the SDP relaxation.

## 1.2. Contributions

In this paper, we adopt a SDP relaxation scheme combined with valid inequalities based on the Sherali-Adams RLT relaxation [43]. The SDP technique aims to find a strong convex model that returns a global minimum of the UC problem. This mathematical programming method has received significant attention due to numerous applications in many fields, including combinatorial and non-convex optimization [45], control theory [46], power systems [30] and facility location problem [47].

In this paper, we provide a set of valid inequalities to attain a tighter description of the feasible operating schedules for the generators in the UC problem. In order to obtain the above-mentioned inequalities, we use RLT to generate valid non-convex quadratic inequalities and then relax them to valid convex inequalities in a lifted space. For instance, we multiply the flow constraints over two different lines to obtain a valid non-convex constraint and then resort to SDP for convexification. The proposed convex program is called a strengthened SDP, which contrasts with the traditional SDP relaxation without valid inequalities. The above procedure is used for producing valid inequalities and its impact on the feasible set of mixed-integer optimization problems is broadly studied in the literature (for instance, see Ref. [48] and the references therein). In this work, we will demonstrate that the strengthened SDP problem is able to find globally optimal discrete solutions for many trials of benchmark systems.

Since the strengthened SDP problem is computationally prohibitive for large power systems, its complexity is reduced through relaxing the high-order SDP constraint to lower-order conic constraints. As will be shown in simulations, the above step significantly reduces the complexity of the strengthened SDP problem without affecting its solution in the test systems. We also introduce the notion of *reliable lower bound* for generators and show that, independent of the objective function, the proposed strengthened convex model is able to recover the correct status of each generators that has a positive reliable lower bound. In the case where the SDP relaxation is not exact, we employ a number of other valid inequalities, including the triangle inequalities and a special case of

the variable upper bound (VUB) ramping constraints [49]. Although the total number of the valid inequalities deployed in this paper is polynomial in the size of the problem, we further reduce it by identifying a subset of implied valid inequalities and removing them from the formulation.

One major benefit of the proposed method compared to the ones in existing literature is that it provides a certificate on the global optimality of the solution. More precisely, the solution obtained for the UC problem is *globally* optimal if the rank of the optimal solution of the strengthened SDP relaxation is equal to one. Using this global optimality certificate, it will be shown that the proposed method finds a global minimum of the UC problem for almost all configurations of the benchmark systems. Another major benefit of the proposed method is that the dual parameters obtained from the proposed convex model automatically coincide with the best set of prices that can be designed to clear the electricity market (known as convex-hull pricing) [50]. More precisely, because of the existence of discrete decision variables in the UC problem, it is often the case that there is no set of prices that supports the optimal solution of the UC problem. This is due to the fact that the prices are often determined by assuming that the decision variables are continuous whereas the actual decision variables do not respect this assumption. Due to this inconsistency, there may be no set of prices that satisfy the market equilibrium with “no arbitrage” property, which can incentivize the generators to change their commitments. The Independent System Operators (ISOs) overcome this issue by proposing the additional uplift payments (in the form of side-payments) to the generators. It has been shown by Gribik et al. [51] that convex-hull pricing is one of the most consistent pricing methods with optimal quantities in the unit commitment problem because of its side-payment minimization property.

Similar to the methods surveyed above, this work studies the UC problem for a linear model of the power flow equations, known as a DC model. Since the UC problem needs to be solved before observing the actual demand and based on the forecasted load over the operating time horizon, the DC model is an acceptable approximation of the power system. However, the results can be applied to a nonlinear AC model of power systems by combining the proposed technique for handling discrete variables with the convexification method delineated by Lavaei et al. [30] for tackling the nonlinearity of continuous variables. The analysis of the success rate of the proposed convex relaxation framework for an AC model of the UC problem is left as future work.

**Notations:** The symbol  $\text{rank}\{\cdot\}$  denotes the rank of a matrix and the notation  $(\cdot)^T$  represents the transpose operator. Vectors and matrices are shown by bold lower case and bold upper case letters, respectively. The notations  $W^{ij}$  and  $W_{ij}$  denote the  $(i,j)^{\text{th}}$  entry of a matrix  $\mathbf{W}$ . Likewise, the notations  $w^i$  and  $w_i$  show the  $i^{\text{th}}$  entry of a vector  $\mathbf{w}$ . The symbols  $\mathbb{R}$  and  $\mathbb{S}^n$  represent the sets of real numbers and  $n \times n$  real symmetric matrices, respectively. The relation  $\mathbf{u} \geq \mathbf{v}$  indicates that the vector  $\mathbf{v}$  is less than or equal to the vector  $\mathbf{u}$  entry-wise (the same relation is used for matrices). Given two sets of natural numbers  $\mathcal{V}_1$  and  $\mathcal{V}_2$  as well as a matrix  $\mathbf{W}$ , the notation  $\mathbf{W}\{\mathcal{V}_1, \mathcal{V}_2\}$  denotes the submatrix of  $\mathbf{W}$  that is obtained by keeping only those rows of  $\mathbf{W}$  corresponding to the set  $\mathcal{V}_1$  and those columns of  $\mathbf{W}$  corresponding to the set  $\mathcal{V}_2$ . Given a vector  $\mathbf{w}$ , the notation  $\mathbf{w}\{\mathcal{V}_1\}$  denotes the subvector of  $\mathbf{w}$  that is obtained by keeping only those elements of  $\mathbf{w}$  corresponding to  $\mathcal{V}_1$ . The notation  $\mathbf{W} > 0$  indicates that  $\mathbf{W}$  is a symmetric positive-semidefinite matrix.

## 2. Problem formulation

Consider a power grid with  $n_b$  buses (nodes),  $n_g$  generators, and

$n_l$  lines. Assume that  $\mathcal{B} = \{1, \dots, n_b\}$ ,  $\mathcal{G} = \{1, \dots, n_g\}$  and  $\mathcal{L} = \{1, \dots, n_l\}$  denote the bus set, generator set and line set, respectively. Moreover, suppose that  $\mathcal{T} = \{0, 1, \dots, t_0, t_0 + 1\}$  is the set of time slots over which the UC problem should be solved. Let  $p_{i,t}$  and  $x_{i,t}$  denote the amount of generation and the status of the generator  $i$  at time  $t$ , respectively, for all  $i \in \mathcal{G}$  and  $t \in \mathcal{T}$ . Assume that the initial ( $t = 0$ ) and terminal ( $t = t_0 + 1$ ) statuses of all generators are off, implying that  $p_{i,0} = x_{i,0} = p_{i,t_0+1} = x_{i,t_0+1} = 0$  for all  $i \in \mathcal{G}$ . The set of the decision variables consists of the continuous variables  $p_{i,t}$  and the binary variables  $x_{i,t}$  for all  $i \in \mathcal{G}$  and  $t \in \mathcal{T}$ . Let  $f_{q,t}$  denote the flow of line  $q \in \mathcal{L}$  (in an arbitrary direction) at time  $t \in \mathcal{T}$ . For the sake of notational simplicity, define  $\mathbf{x}_t$  as the vector of all commitment statuses and  $\mathbf{p}_t$  as the vector of all generator outputs at time  $t \in \mathcal{T}$ :

$$\mathbf{X}_t \triangleq [x_{1,t}, \dots, x_{n_g,t}]^T, \quad \mathbf{P}_t \triangleq [p_{1,t}, \dots, p_{n_g,t}]^T.$$

The objective function of the UC problem is the sum of the operational costs of all generating units, which consist of the power generation, start-up and shut-down costs. The power generation cost is commonly modeled as a quadratic function with respect to the amount of generation:

$$g_{i,t}(p_{i,t}, x_{i,t}) \triangleq a_i \times p_{i,t}^2 + b_i \times p_{i,t} + c_{i,\text{fixed}} \times x_{i,t}, \quad (1)$$

where  $a_i$ ,  $b_i$ , and  $c_{i,\text{fixed}}$  are constant coefficients for generator  $i$ . Note that the term  $c_{i,\text{fixed}} \times x_{i,t}$  accounts for a fixed cost if the generator is on and becomes zero otherwise. The start-up and shut-down costs are both assumed to be identical and modeled as

$$h_{i,t}(x_{i,t+1}, x_{i,t}) \triangleq c_{i,\text{start}} \cdot (x_{i,t+1} - x_{i,t})^2, \quad (2)$$

where  $c_{i,\text{start}}$  is the amount of start-up or shut-down cost. Note that since all generators are assumed to be off at the beginning and the end of the horizon (i.e.,  $t = 0$  and  $t = t_0 + 1$ ), if the start-up and shut-down costs have different values, we can precisely model the problem using the expression (2) after setting  $c_{i,\text{start}}$  equal to the average of those two different costs.

**Remark 1.** The fuel cost could be a piecewise function, and therefore possibly nonconvex, for certain types of generators due to the valve-point loading effect. The non-smoothness of the fuel cost is often caused by the fact that the status of the input valve of a generator could be changed sequentially based on the loading outputs to increase the efficiency of the power plant [52]. Recently, much attention has been devoted to taking the valve-point loading effect into consideration for the UC and economic dispatch problems [53]. The non-convexity of the fuel cost function can be addressed by first finding a piecewise linear approximation of the function (with any arbitrary precision) and then defining additional binary variables to take care of the break points. While the focus of this work is merely on the UC problem with quadratic objective functions (and linear functions as a special case), the methodology to be developed in this paper could be generalized to handle piecewise nonconvex cost functions through new binary variables. A careful analysis of this generalization is left as future work due to space restrictions.

The cost associated with turning on or off a generator induces a coupling between the decision variables at different times. There are some operational restrictions for the UC problem, such as physical limits and security constraints. Physical limits include unit capacity, line capacity, ramping, minimum up-time, and minimum down-time constraints. A unit capacity constraint ensures that the unit operates within certain limits. A line capacity constraint enforces the flow on each transmission line not to exceed its thermal



limit. Due to the physical design of a generator, it may be impossible to significantly change the production level within a short time interval. These restrictions are referred to as ramping constraints. In addition, each generator may have minimum up-time and down-time constraints, which prohibit the status of a generator from changing over a short period of time.

In order to formulate the UC problem, we need to define several parameters below. Define the vector of demands at time  $t$  as  $\mathbf{d}_t$ , where its  $j^{\text{th}}$  entry is equal to the demand at bus  $j \in \mathcal{B}$  at time  $t \in \mathcal{T}$  (shown as  $d_{j,t}$ ). Let  $\mathbf{f}_{\max}$  denote the maximum flow vector for all transmission lines, where its  $q^{\text{th}}$  entry is equal to the flow limit for the line  $q \in \mathcal{L}$  (shown as  $f_{q,\max}$ ). Assume that  $p_{i,\max}$  and  $p_{i,\min}$  represent the upper and lower bounds on the generation of unit  $i \in \mathcal{G}$ , respectively. Furthermore, define  $s_i$  as the maximum amount of generation for the start-up and shut-down of generator  $i \in \mathcal{G}$ . Moreover,  $r_i$  denotes the maximum difference between the generations at two adjacent operating time slots for generator  $i$ . Furthermore, suppose that  $U_i$  and  $D_i$  denote the minimum up-time and down-time for generator  $i$ , respectively. Let  $\mathbf{H}$  be the power transfer distribution factors (PTDF) or shift factor matrix and  $\mathbf{C}_g \in \mathbb{R}^{n_b \times n_g}$  be the bus-to-generator incidence matrix. Note that  $C_{gji} = 1$  if and only if generator  $i$  is connected to bus  $j$ , and  $C_{gji} = 0$  otherwise. Since we adopt the DC modeling of the UC problem, the flow of each line  $q$  at time  $t$  (shown as  $f_{q,t}$ ) can be expressed as a linear combination of all generations at time  $t$ . Therefore, the UC problem can be formulated as follows:

$$\min_{\substack{\{x_{i,t}\} \\ \{p_{i,t}\}}} \sum_{i \in \mathcal{G}} g_{i,t}(p_{i,t}, x_{i,t}) + \sum_{i \in \mathcal{G}} h_{i,t}(x_{i,t+1}, x_{i,t}), \quad (3a)$$

$$\text{subject to } x_{i,t} \in \{0, 1\}, \quad (3b)$$

$$p_{i,\min} \times x_{i,t} \leq p_{i,t} \leq p_{i,\max} \times x_{i,t}, \quad (3c)$$

$$\sum_{i=1}^{n_g} p_{i,t} = \sum_{j=1}^{n_b} d_{j,t}, \quad (3d)$$

$$|\mathbf{H}(\mathbf{d}_t - \mathbf{C}_g \mathbf{p}_t)| \leq \mathbf{f}_{\max}, \quad (3e)$$

$$|p_{i,t+1} - p_{i,t}| \leq (2s_i - r_i) + (r_i - s_i)(x_{i,t+1} + x_{i,t}), \quad (3f)$$

$$x_{i,t+1} - x_{i,t} \leq x_{i,\tau}, \quad \forall \tau \in \{t+1, \dots, \min(t+U_i, t_0)\}, \quad (3g)$$

$$x_{i,t-1} - x_{i,t} \leq 1 - x_{i,\tau}, \quad \forall \tau \in \{t+1, \dots, \min(t+D_i, t_0)\}, \quad (3h)$$

$$i \in \mathcal{G}; t \in \overline{\mathcal{T}} \quad (3i)$$

where:

- $\overline{\mathcal{T}} \triangleq \{1, 2, \dots, t_0\}$  and  $\overline{\mathcal{T}}_0 \triangleq \{0, 1, 2, \dots, t_0\}$ .
- (3b) imposes that status of each generator to be binary and holds for all  $i \in \mathcal{G}$  and  $t \in \overline{\mathcal{T}}$ .
- (3c) is the unit capacity constraint and holds for all  $i \in \mathcal{G}$  and  $t \in \overline{\mathcal{T}}$ .
- (3d) represents the power balance equation and holds for all  $i \in \mathcal{G}$  and  $t \in \overline{\mathcal{T}}$ .
- (3e) indicates the line capacity constraint and holds for all  $t \in \overline{\mathcal{T}}$ .
- (3f) formulates the ramping constraint and holds for all  $i \in \mathcal{G}$  and  $t \in \overline{\mathcal{T}}_0$ .

- (3g) is the minimum up-time constraint and holds for all  $i \in \mathcal{G}$  and  $t \in \overline{\mathcal{T}}_0$ .
- (3h) is the minimum down-time constraint and holds for all  $i \in \mathcal{G}$  and  $t \in \overline{\mathcal{T}}_0$ .

Note that the security constraints have not been modeled explicitly in order to streamline the presentation. However, the results to be presented in this work are valid in presence of linear security constraints obtained using line outage distribution factors [54].

**Remark 2.** Inequality (3f) encapsulates two types of ramping constraints. More precisely, it imposes the inequality  $|p_{i,t+1} - p_{i,t}| \leq r_i$  in the case of  $x_{i,t+1} = x_{i,t} = 1$  and the inequality  $|p_{i,t+1} - p_{i,t}| \leq s_i$  in the case of  $x_{i,t+1} \neq x_{i,t}$ .

**Remark 3.** Constraints (3c)–(3h) can all be formulated linearly in terms of the decision variables.

### 3. Convex relaxation and strengthening of UC problem

In what follows, the main results of this paper will be developed. To streamline the presentation, the proofs are moved to the appendix. As mentioned in the Introduction, the focus of this paper is on convex formulations of the UC problem. To this goal, a convex relaxation of the UC problem is first introduced. Subsequently, this relaxation is strengthened with a set of valid inequalities. Through extensive simulations on benchmark systems combined with rigorous theoretical results, we will show that the proposed convex formulation is indeed exact under different scenarios. To explain the *convex relaxation* and *strengthening* steps, consider the simple illustrative example given in Fig. D.1. The original feasible region consists of 4 discrete points. In the convex relaxation step, the non-convex and disjoint feasible region is embedded (relaxed) into a convex region (depicted by the green ellipse). This convex region contains the original feasible region, together with a new set of infeasible points. In the second step, the convex relaxation of the feasible region is strengthened by adding a set of *valid inequalities*, namely those constraints that are guaranteed to be satisfied by the original feasible points. The role of these valid inequalities is to strengthen the convex representation of the original feasible region by eliminating some of the potentially infeasible points introduced in the convex relaxation step. The pink diamond in Fig. D.1 shows the resulting feasible region after strengthening the convex relaxation via valid inequalities.

The tightest convex relaxation of a nonconvex feasible region (known as the convex-hull of the feasible region) has an important property: optimizing any linear function over this convex region results in a solution that is globally optimal for the original non-convex problem. However, finding the convex-hull can be as hard as obtaining a global minimum of the original problem [55]. Despite this negative result, one goal of this paper is to show that it is possible to obtain a tight convex relaxation of the UC problem under various conditions for practical benchmark systems. This convex model is valuable for convex-hull pricing and sensitivity analysis in energy markets [51]. Furthermore, the convex nature of the proposed model makes it possible to solve the problem using standard numerical algorithms with any arbitrary initialization. Moreover, the proposed method serves as a global optimization technique, meaning that it aims at finding the best solution possible for the UC problem.

In the rest of this section, a convex relaxation of the UC problem in a lifted space will be introduced, followed by a procedure to strengthen the convex model using a set of valid inequalities.

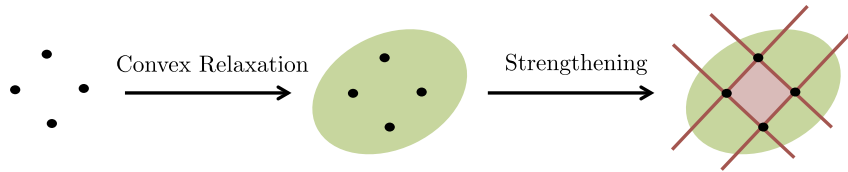

Fig. D.1. Convex Relaxation and Strengthening of a non-convex feasible region.

3.1. SDP relaxations

By relaxing the integrality condition (3b) to the linear constraints

$$0 \leq x_{i,t} \leq 1, \tag{4}$$

we obtain the **basic (convex) quadratic programming (QP) relaxation of the UC problem**. As will be shown in Section 4, the solution of this convex problem is almost always fractional for benchmark systems. Motivated by this observation, the objective is to design stronger relaxations. Consider the vector

$$\mathbf{w} \triangleq [\mathbf{x}_1^\top, \dots, \mathbf{x}_{t_0}^\top, \mathbf{p}_1^\top, \dots, \mathbf{p}_{t_0}^\top]^\top. \tag{5}$$

The constraint (4) together with the constraints of the UC problem except for (3b) can all be merged into a single linear vector constraint  $\mathbf{M}\mathbf{w} \geq \mathbf{m}$ , for some constant matrix  $\mathbf{M}$  and vector  $\mathbf{m}$ . Furthermore, the condition (3b) can be expressed as the quadratic equation

$$x_{i,t}(x_{i,t} - 1) = 0. \tag{6}$$

Therefore, the UC problem can be stated as

$$\text{minimize}_{\mathbf{w} \in \mathbb{R}^{2n_g t_0}} c(\mathbf{w}) \tag{7a}$$

$$\text{subject to } \mathbf{M}\mathbf{w} \geq \mathbf{m}, \tag{7b}$$

$$w_k(w_k - 1) = 0, \quad k = 1, 2, \dots, n_g t_0, \tag{7c}$$

where  $c(\mathbf{w})$  is equivalent to the total cost of the UC problem. It is straightforward to verify that  $c(\mathbf{w})$  is a convex function with respect to  $\mathbf{w}$ . Note that this formulation is obtained by writing each equality constraint of the UC problem as two inequality constraints.

**Remark 4.** Let  $\mathbf{0}_{a \times b}$  and  $\mathbf{1}_{a \times b}$  denote  $a \times b$  matrices with all entries equal to 0's and 1's, respectively. Moreover, let  $\mathbf{I}_n$  be the  $n \times n$  identity matrix. Given a vector  $\mathbf{p}$ , the notation  $\text{diag}\{\mathbf{p}\}$  represents a diagonal matrix such that the  $(i, i)^{\text{th}}$  entry equals  $p_i$ . Assume that the  $i^{\text{th}}$  entries of the vectors  $\mathbf{p}_{\max}$  and  $\mathbf{p}_{\min}$  represent the upper and lower bounds on the generation of unit  $i \in \mathcal{G}$ , respectively. In order to elaborate on the reformulation (7) and the structure of its parameters, note that

$$\mathbf{M} = \begin{bmatrix} \mathbf{I}_{n_g} & \mathbf{0}_{n_g \times n_g} \\ -\mathbf{I}_{n_g} & \mathbf{0}_{n_g \times n_g} \\ -\text{diag}\{\mathbf{p}_{\min}\} & \mathbf{I}_{n_g} \\ \text{diag}\{\mathbf{p}_{\max}\} & -\mathbf{I}_{n_g} \\ \mathbf{0}_{1 \times n_g} & \mathbf{1}_{1 \times n_g} \\ \mathbf{0}_{1 \times n_g} & -\mathbf{1}_{1 \times n_g} \\ \mathbf{0}_{n_1 \times n_g} & \mathbf{H.C}_g \\ \mathbf{0}_{n_1 \times n_g} & -\mathbf{H.C}_g \end{bmatrix}, \quad \mathbf{m} = \begin{bmatrix} \mathbf{0}_{n_g \times 1} \\ -\mathbf{1}_{n_g \times 1} \\ \mathbf{0}_{n_g \times 1} \\ \mathbf{0}_{n_g \times 1} \\ \sum_{j=1}^{n_b} d_j \\ -\sum_{j=1}^{n_b} d_j \\ \mathbf{H.d} - \mathbf{f}_{\max} \\ -\mathbf{H.d} - \mathbf{f}_{\max} \end{bmatrix}, \tag{8}$$

in the case  $t_0 = 1$ .

Consider a matrix variable  $\mathbf{W}$  and set it to  $\mathbf{w}\mathbf{w}^\top$ . The constraints of the UC problem can all be written as inequalities in terms of  $\mathbf{W}$  and  $\mathbf{w}$ . This leads to a reformulation of the UC problem, where  $\mathbf{W} = \mathbf{w}\mathbf{w}^\top$  is the only non-convex constraint. An SDP relaxation of the UC problem can be obtained by relaxing  $\mathbf{W} = \mathbf{w}\mathbf{w}^\top$  to the conic constraint  $\mathbf{W} \succeq \mathbf{w}\mathbf{w}^\top$ . This yields the convex optimization problem

$$\begin{aligned} &\text{minimize}_{\substack{\mathbf{w} \in \mathbb{R}^{2n_g t_0} \\ \mathbf{W} \in \mathbb{S}^{2n_g t_0}}} c_r(\mathbf{w}, \mathbf{W}) \end{aligned} \tag{9a}$$

$$\text{subject to } \mathbf{M}\mathbf{w} \geq \mathbf{m}, \tag{9b}$$

$$W_{kk} - w_k = 0, \quad k = 1, 2, \dots, n_g t_0, \tag{9c}$$

$$\mathbf{W} \succeq \mathbf{w}\mathbf{w}^\top, \tag{9d}$$

where

$$\begin{aligned} c_r(\mathbf{w}, \mathbf{W}) = &\sum_{\substack{i \in \mathcal{G} \\ t \in \overline{\mathcal{F}}}} (a_i W_{n_g t_0 + n_g(t-1)+i, n_g t_0 + n_g(t-1)+i} \\ &+ b_i W_{n_g t_0 + n_g(t-1)+i} \\ &+ c_{i,\text{fixed}} W_{n_g(t-1)+i} + \sum_{\substack{i \in \mathcal{G} \\ t \in \mathcal{F}_0}} c_{i,\text{start}} \cdot (W_{n_g t+i, n_g t+i} \\ &+ W_{n_g(t-1)+i, n_g(t-1)+i} - W_{n_g t+i, n_g(t-1)+i} \\ &- W_{n_g(t-1)+i, n_g t+i}). \end{aligned} \tag{10}$$

Note that (9d) can be written as a linear matrix inequality with respect to  $\mathbf{w}$  and  $\mathbf{W}$ . This problem is called the **SDP relaxation of the UC problem**.

**Remark 5.** Note that (9) is indeed a relaxation of the UC problem. This is due to the fact that if  $\mathbf{w}$ , defined in (5), is an optimal solution of the UC problem, then  $(\mathbf{w}, \mathbf{w}\mathbf{w}^\top)$  is feasible for (9) and has the same objective value as the optimal cost of the UC problem. Furthermore, the proposed SDP relaxation solves the UC problem if and only if it has an optimal solution  $(\mathbf{w}^*, \mathbf{W}^*)$  for which the matrix

$$\begin{bmatrix} \mathbf{1} & \mathbf{w}^{*\top} \\ \mathbf{w}^* & \mathbf{W}^* \end{bmatrix}$$

has rank 1. From a different perspective, in the case where  $x_{i,t}^*$ 's are all binary numbers at an optimal solution of (9), the relaxation is exact.

As will be demonstrated in Section 4, the solution of the convex problem (9) is almost always fractional for benchmark systems. In fact, we show in Appendix A that the optimal objective values of SDP and QP relaxations of the UC problem are equal when  $t_0 = 1$ .

### 3.2. Valid inequalities

Let  $S$  denote the set of feasible points of the UC problem (3). An inequality is said to be valid if it is satisfied by all points in  $S$ . The SDP relaxation (9) can be strengthened by adding valid inequalities to the problem. Consider two scalar inequalities of the UC problem, namely

$$\mathbf{u}^T \mathbf{w} - z_1 \geq 0, \quad \mathbf{v}^T \mathbf{w} - z_2 \geq 0,$$

for fixed coefficients  $\mathbf{u}, \mathbf{v}, z_1$  and  $z_2$ . Since both of these inequalities hold for all points  $\mathbf{w}$  in  $S$ , the quadratic inequality

$$\mathbf{u}^T \mathbf{w} \mathbf{w}^T \mathbf{v} - (\mathbf{v}^T z_1 + \mathbf{u}^T z_2) \mathbf{w} + z_1 z_2 \geq 0,$$

is also satisfied for every  $\mathbf{w} \in S$ . The above quadratic inequality can be relaxed to the linear inequality

$$\mathbf{u}^T \mathbf{W} \mathbf{v} - (\mathbf{v}^T z_1 + \mathbf{u}^T z_2) \mathbf{w} + z_1 z_2 \geq 0.$$

### 3.3. Strengthened SDP relaxation

In this part, we construct a set of valid inequalities via the multiplication of all linear inequalities of the UC problem, using the strategy delineated in Section 3.2. The resulting quadratic inequalities obtained from (9b) can be expressed as the matrix constraint  $(\mathbf{M}\mathbf{w} - \mathbf{m})(\mathbf{M}\mathbf{w} - \mathbf{m})^T \geq 0$ , or equivalently,

$$\mathbf{M}\mathbf{w}\mathbf{w}^T \mathbf{M}^T - \mathbf{m}\mathbf{w}^T \mathbf{M}^T - \mathbf{M}\mathbf{w}\mathbf{m}^T + \mathbf{m}\mathbf{m}^T \geq 0.$$

The relaxation of this non-convex inequality yields the linear matrix inequality

$$\mathbf{M}\mathbf{W}\mathbf{M}^T - \mathbf{m}\mathbf{w}^T \mathbf{M}^T - \mathbf{M}\mathbf{w}\mathbf{m}^T + \mathbf{m}\mathbf{m}^T \geq 0. \quad (11)$$

Replacing the non-convex constraint (7c) in the UC formulation (7) with the linear constraint (11) leads to a **Reformulation-Linearization Technique (RLT) relaxation of the UC problem**. Although it has been proven in Ref. [43] that this relaxation outperforms the basic QP relaxation, it is shown in Section 4 that this method often fails to generate feasible solutions for the UC problem.

The addition of the constraint (11) to the SDP relaxation (9) leads to the convex optimization problem:

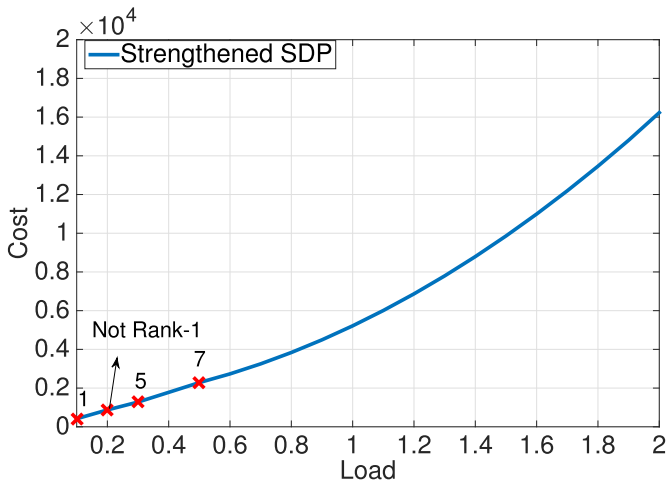

(a) Strengthened SDP

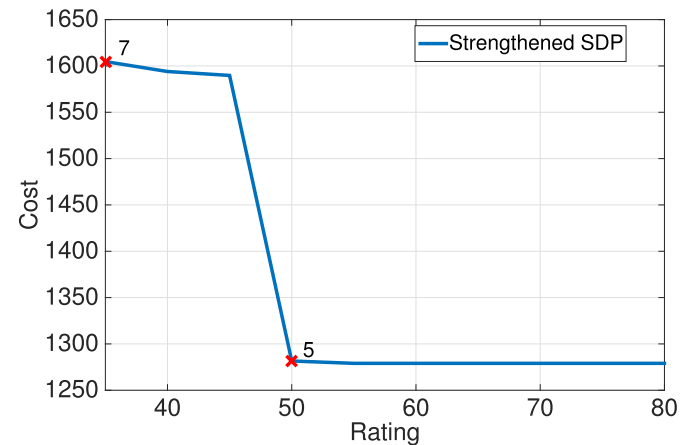

(a) Strengthened SDP

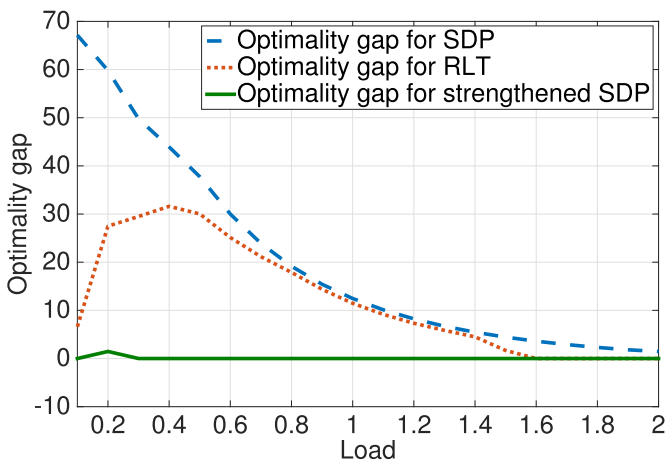

(b) Optimality Gap

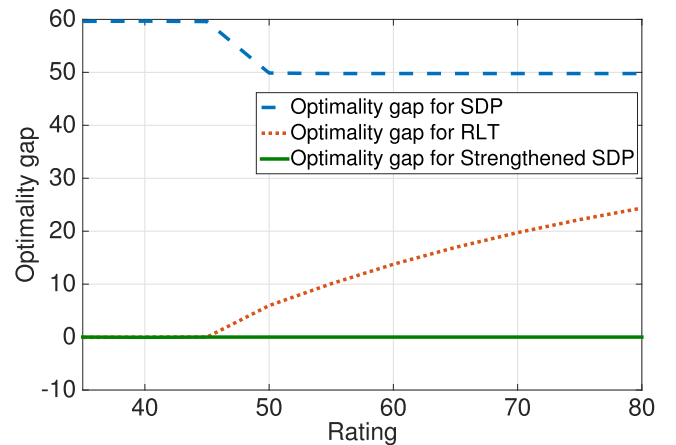

(b) Optimality Gap

Fig. D.2. 20 load scenarios for the IEEE 9-bus system with 3 generators over one time slot.

Fig. D.3. 10 line rating scenarios for the IEEE 9-bus system with 3 generators over one time slot with the load factor 0.3.

$$\text{minimize } c_r(\mathbf{w}, \mathbf{W}) \tag{12a}$$

$$\begin{aligned} \mathbf{w} &\in \mathbb{R}^{2n_g t_0} \\ \mathbf{W} &\in \mathbb{S}^{2n_g t_0} \end{aligned}$$

$$\text{subject to } \mathbf{M}\mathbf{w} \geq \mathbf{m}, \tag{12b}$$

$$\mathbf{M}\mathbf{W}\mathbf{M}^T - \mathbf{m}\mathbf{w}^T\mathbf{M}^T - \mathbf{M}\mathbf{w}\mathbf{m}^T + \mathbf{m}\mathbf{m}^T \geq 0, \tag{12c}$$

$$W_{kk} - w_k = 0, \quad k = 1, 2, \dots, n_g t_0, \tag{12d}$$

$$\mathbf{W} \succeq \mathbf{w}\mathbf{w}^T. \tag{12e}$$

This problem is referred to as the **strengthened SDP relaxation of the UC problem**. In Appendix C, it is shown that the strengthened SDP (12) is exact and significantly improves the standard SDP and RLT relaxations for most test cases.

Real-world UC problems are large-scale due to the size of power grids and the number of time slots. Hence, the strengthened SDP relaxation (12) would be computationally expensive for practical systems. Later in this paper, constraint (12e) will be replaced by a number of lower-order conic constraints without affecting the solution.

### 3.4. Reduced-strengthened SDP relaxation

In this subsection, we design a reduced-strengthened SDP relaxation with conic constraints smaller than that of the strengthened SDP relaxation.

Define the sets

$$\mathcal{V}_{x_t} \triangleq \{n_g(t-1) + 1, n_g(t-1) + 2, \dots, n_g(t+1)\},$$

$$\mathcal{V}_{p_t} \triangleq \{n_g(t_0 + t - 1) + 1, n_g(t_0 + t - 1) + 2, \dots, n_g(t_0 + t + 1)\},$$

$$\mathcal{V}_t \triangleq \mathcal{V}_{x_t} \cup \mathcal{V}_{p_t}$$

for every  $t \in \{1, \dots, t_0 - 1\}$ . Observe that  $\mathcal{V}_{x_t}$  and  $\mathcal{V}_{p_t}$  are the index sets of those elements of  $\mathbf{w}$  that correspond to  $\{x_{1:t}, \dots, x_{n_g:t}, x_{1:t+1}, \dots, x_{n_g:t+1}\}$  and  $\{p_{1:t}, \dots, p_{n_g:t}, p_{1:t+1}, \dots, p_{n_g:t+1}\}$ , respectively. There are constant matrices  $\mathbf{Y}_1, \dots, \mathbf{Y}_{t_0-1}$  and vectors  $\mathbf{y}_1, \dots, \mathbf{y}_{t_0-1}$  such that, for every  $t \in \{1, \dots, t_0 - 1\}$ , the inequality

$$\mathbf{Y}_t \mathbf{w}_{\{\mathcal{V}_t\}} \geq \mathbf{y}_t \tag{13}$$

is equivalent to the collection of those inequalities in (9b) that only include the decision variables  $x_{i:t}, p_{i:t}, x_{i:t+1}$ , and  $p_{i:t+1}$  for all  $i \in \mathcal{S}$ . Note that the inequalities given in (13) for  $t \in \{1, \dots, t_0 - 1\}$  cover all inequalities in (9b) except for the minimum up-time and down-time constraints.

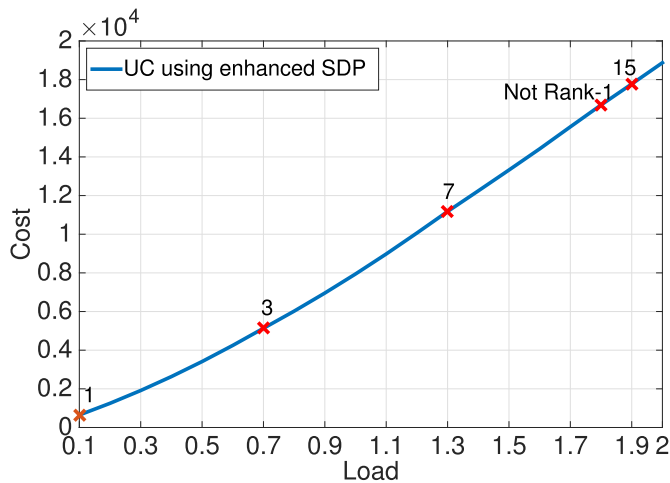

(a) Strengthened SDP

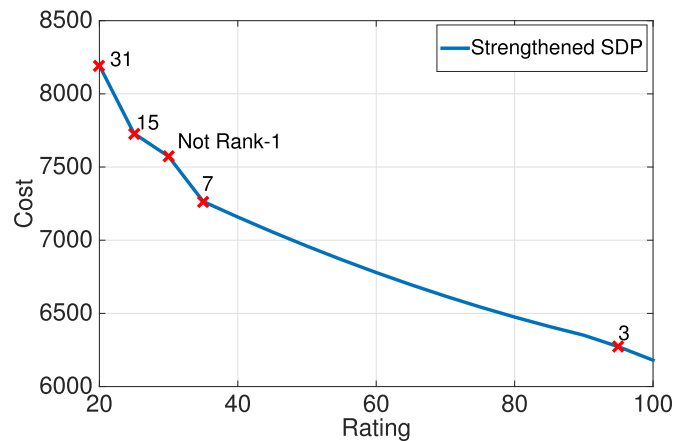

(a) Strengthened SDP

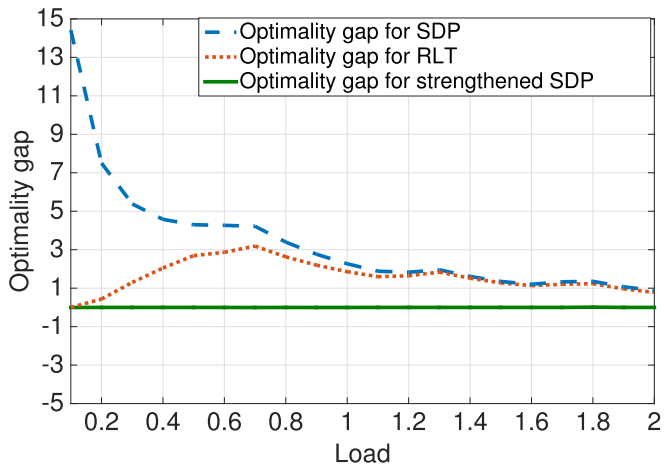

(b) Optimality Gap

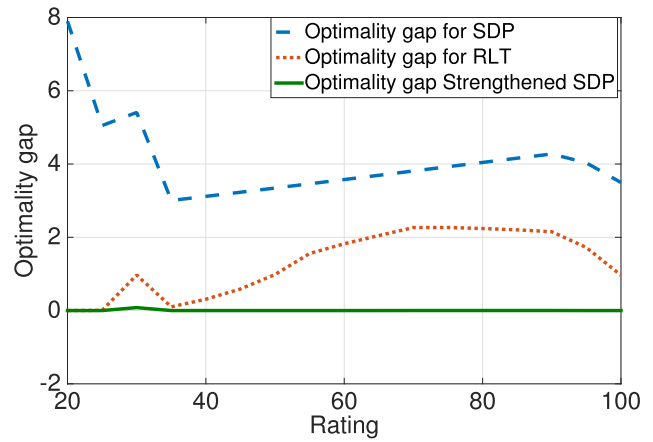

(b) Optimality Gap

Fig. D.4. 20 load scenarios for the IEEE 14-bus system with 5 generators over one time slot.

Fig. D.5. 17 line rating scenarios for the IEEE 14-bus system with 5 generators over one time slot with the load factor 0.8.



To handle the minimum up- and down-time constraints, define the set  $\mathcal{V}_{t_0} \triangleq \{1, \dots, n_g t_0\}$ . Note that  $\mathcal{V}_{t_0}$  is the index set of those elements of  $\mathbf{w}$  that correspond to the statuses of the generators over different time slots. There are a matrix  $\mathbf{Y}_{t_0}$  and a vector  $\mathbf{y}_{t_0}$  such that the inequality

$$\mathbf{Y}_{t_0} \mathbf{w}_{\{\mathcal{V}_{t_0}\}} \geq \mathbf{y}_{t_0} \quad (14)$$

is equivalent to the minimum up- and down-time constraints (3g) and (3h). Note that these constraints are inherently linear functions of the variables  $x_{i,t}$ 's.

So far, it has been shown that the condition (9b) can be replaced by (13) and (14) for  $t = 1, \dots, t_0$ . Based on this fact, we introduce a relaxation of the strengthened SDP problem as follows:

$$\begin{aligned} &\text{minimize } c_r(\mathbf{w}, \mathbf{W}) && (15a) \\ &\mathbf{w} \in \mathbb{R}^{2n_g t_0} \\ &\mathbf{W} \in \mathbb{S}^{2n_g t_0} \end{aligned}$$

$$\text{subject to } \mathbf{Y}_t \mathbf{w}_{\{\mathcal{V}_t\}} \geq \mathbf{y}_t, \quad t = 1, 2, \dots, t_0, \quad (15b)$$

$$\mathbf{Y}_t \mathbf{W}_{\{\mathcal{V}_t, \mathcal{V}_t\}} \mathbf{Y}_t^T - \mathbf{y}_t \mathbf{w}_{\{\mathcal{V}_t\}}^T \mathbf{Y}_t^T$$

$$-\mathbf{Y}_t \mathbf{w}_{\{\mathcal{V}_t\}} \mathbf{y}_t^T + \mathbf{y}_t \mathbf{y}_t^T \geq 0,$$

$$t = 1, 2, \dots, t_0, \quad (15c)$$

$$W_{kk} - w_k = 0, \quad k = 1, 2, \dots, n_g t_0, \quad (15d)$$

$$\mathbf{W} \succeq \mathbf{w} \mathbf{w}^T. \quad (15e)$$

After this relaxation, the exactness of the proposed relaxation can be certified if and only if the variables  $x_{i,t}$ 's take binary values at optimality. Furthermore, the large conic constraint (15e) can be broken down into smaller conic constraints. In particular, the conic constraint  $\mathbf{W} \succeq \mathbf{w} \mathbf{w}^T$  is equivalent to  $\mathbf{W}_{\{\mathcal{V}_t, \mathcal{V}_t\}} \succeq \mathbf{w}_{\{\mathcal{V}_t\}} \mathbf{w}_{\{\mathcal{V}_t\}}^T$  for  $t = 1, 2, \dots, t_0$  in the absence of minimum up- and down-time constraints. Notice that the later constraints are defined on smaller sized matrices that are defined based on  $\mathcal{V}_t$ . The proof of this statement can be found in Appendix B.

Substituting (15e) with  $\mathbf{W}_{\{\mathcal{V}_t, \mathcal{V}_t\}} \succeq \mathbf{w}_{\{\mathcal{V}_t\}} \mathbf{w}_{\{\mathcal{V}_t\}}^T$  for  $t = 1, 2, \dots, t_0$  gives rise to the **reduced-strengthened SDP relaxation** of UC problem. It is worthwhile to mention that some of the designed valid inequalities are redundant and implied by other inequalities. In order to further reduce the computational complexity of the designed relaxation, these redundant inequalities

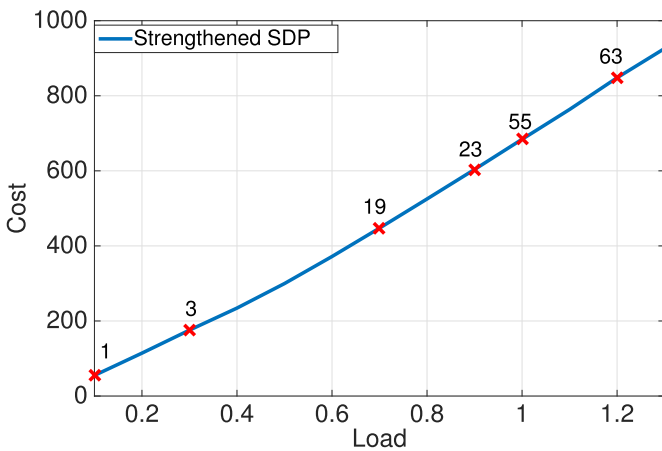

(a) Strengthened SDP

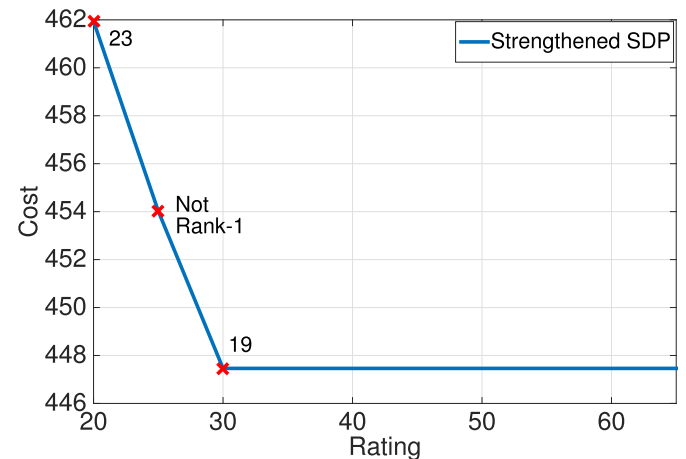

(a) Strengthened SDP

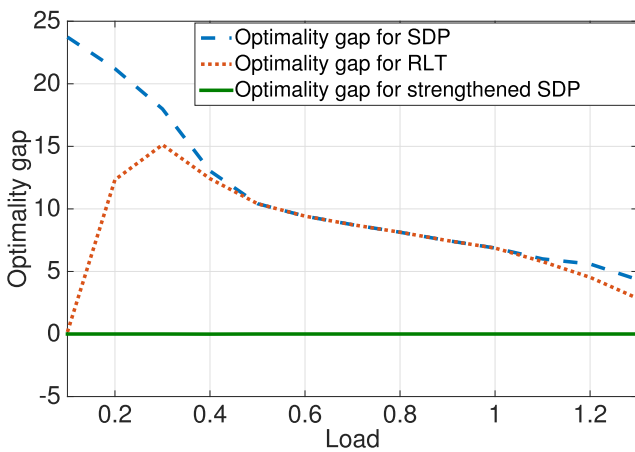

(b) Optimality Gap

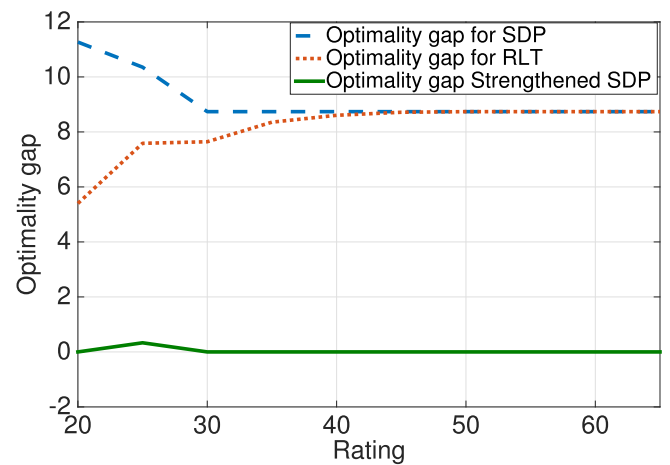

(b) Optimality Gap

Fig. D.6. 13 load scenarios for the IEEE 30-bus system with 6 generators over one time slot.

Fig. D.7. 10 line rating scenarios for the IEEE 30-bus system with 6 generators over one time slot with the load factor 0.7.

are identified in Appendix D and removed from the formulation.

One may speculate that more valid inequalities in the strengthened SDP problem can be declared redundant and eliminated by analyzing the geographical locations of generators and lines. In particular, a question arises as to whether it is necessary to incorporate those valid inequalities that are obtained by multiplying the constraints of two devices (lines or generators) that are geographically far from each other. As will be shown in simulations on a test system, such valid inequalities may be crucial for the exactness of the strengthened SDP relaxation.

### 3.5. Triangle and VUB constraints

It will be shown in simulations that the proposed SDP relaxations are able to find a global solution of the UC problem for many test systems under various conditions. However, there are cases for which the relaxations are not exact. To further improve the relaxations for such systems, the so-called triangle inequalities are incorporated in the UC problem.

$$x_{i,t}x_{j,t} + x_{k,t} \geq x_{i,t}x_{k,t} + x_{j,t}x_{k,t},$$

$$x_{i,t}x_{j,t} + x_{i,t}x_{k,t} + x_{j,t}x_{k,t} + 1 \geq x_{i,t} + x_{j,t} + x_{k,t},$$

for every  $i, j, k \in \mathcal{S}$  and  $t \in \mathcal{T}$ . The efficacy of these valid inequalities has been studied by Burer et al. [49] and Anstreicher et al. [48]. Moreover, the proposed method is reinforced by adding the VUB ramp constraints

$$p_{i,t} \leq p_{i, \max} \cdot x_{i,t} - (p_{i, \max} - s_i) \cdot (x_{i,t} - x_{i,t-1}),$$

$$p_{i,t} \leq p_{i, \max} \cdot x_{i,t} - (p_{i, \max} - s_i) \cdot (x_{i,t} - x_{i,t+1}),$$

developed by Damcı-Kurt et al. [15]. Note that the above valid inequalities are a subclass of VUB ramp constraints for only two adjacent time slots. Although the number of all VUB ramp constraints is exponential in the size of the UC problem, the number of the inequalities considered above (for adjacent time slots) is linear.

## 4. Case studies

In this section, several case studies on IEEE benchmark systems will be provided. The simulations are run on a laptop computer with an Intel Core i7 quad-core 2.50 GHz CPU and 16GB RAM. The results are reported based on a serial implementation in MATLAB

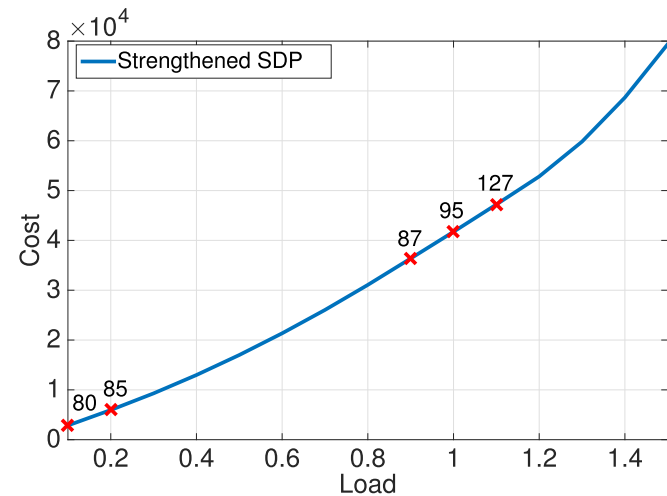

(a) Strengthened SDP

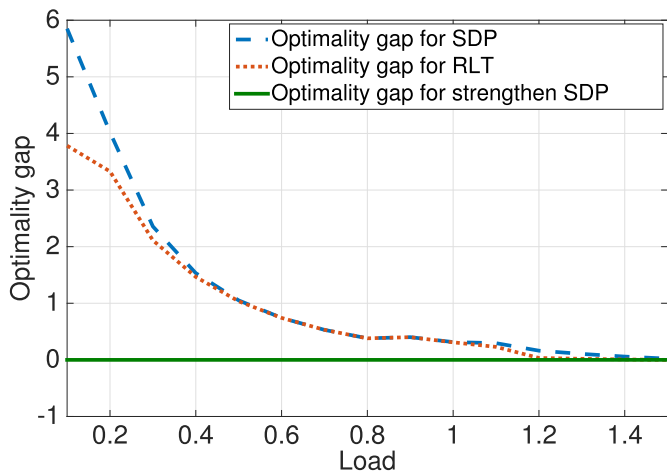

(b) Optimality Gap

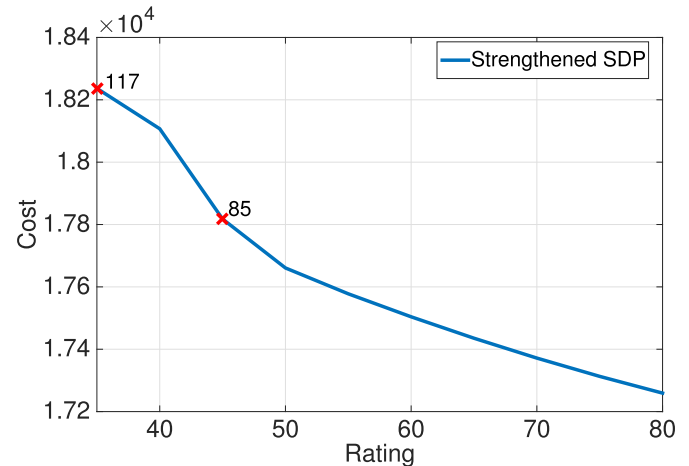

(a) Strengthened SDP

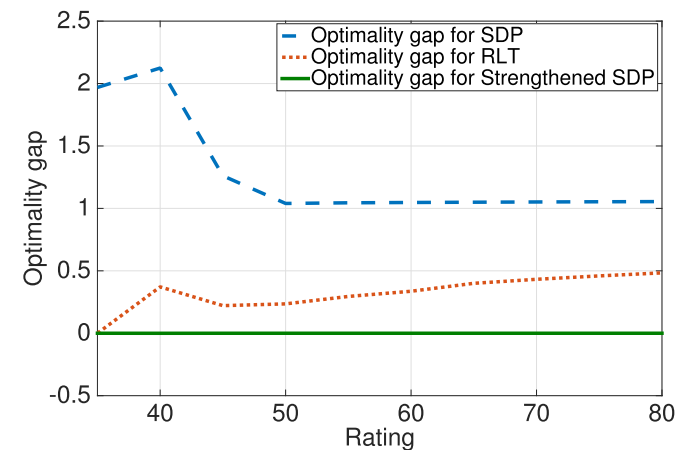

(b) Optimality Gap

Fig. D.8. 15 load scenarios for the IEEE 57-bus system with 7 generators over one time slot.

Fig. D.9. 10 line rating scenarios for the IEEE 57-bus system with 7 generators over one time slot with the load factor 0.5.

using the CVX framework and MOSEK solver that utilizes an interior-point algorithm to solve SDP problems [56]. For all test cases, the objective function is quadratic in the generator output and linear in the commitment status. To generate multiple UC problems for each test case, we multiply all loads of each IEEE system by a load factor  $\alpha$  chosen from a discrete set  $\{\alpha_1, \alpha_2, \dots, \alpha_k\}$ . For each IEEE system, we plot four curves for  $k$  load profiles: (i) the optimal cost of the (reduced) strengthened SDP, (ii) the optimality gaps for three different relaxations (SDP, strengthened SDP and RLT). As the load factor changes from  $\alpha_1$  to  $\alpha_k$ , the optimal statuses of the generators may change multiple times. Whenever the statuses of the generators for a load/rating scenario varies from those of the previous one, the corresponding scenario is marked on the curve by a red cross. Hence, if there is no mark on the SDP cost curve for a particular load/rating scenario, it means that the statuses of the generators are the same as those in the previous load scenario. Each red cross is accompanied by an integer number, which can be interpreted as follows: if this number is converted from base 10 to 2, it is the concatenation of the globally optimal status of all generators. For example, for a case with 3 generators, the number 5 on the SDP cost curve indicates that the first and third generators are active while the second generator is off at a globally optimal solution of UC (note that  $5 = (101)_2$ ). Moreover, for every

scenario that at least one of generator statuses found by the strengthened SDP is neither 0 nor 1, we write “Not Rank-1” on the curve instead of an integer number encoding the optimal generator statuses. To further assess the performance of the proposed relaxations, we redo the above experiment for each test case and draw curves with respect to line ratings as opposed to load factors. More precisely, we impose a constant limit on the flows of all lines and solve various relaxations of the UC problem for different values of this limit.

Fig. D.2(a) shows the solutions found by the strengthened SDP for 20 load scenarios for the IEEE 9-bus system with 3 generators over one time slot ( $t_0 = 1$ ). The load factors are  $\alpha_i = 0.1 \times i$  for  $i = 1, 2, \dots, 20$ . It can be observed that the proposed convex relaxation has found a global solution of the UC problem for 19 out of 20 scenarios. The load profile associated with the factor  $\alpha_2$  is the only unsuccessful case. After adding triangle constraints to the formulation, the relaxation becomes exact and it retrieves the optimal solution of UC problem.

We define the optimality gap for any relaxation of the UC problem as

$$\text{Optimality gap} \triangleq \frac{\text{upper bound} - \text{lower bound}}{\text{upper bound}} \times 100,$$

where “upper bound” and “lower bound” denote the globally

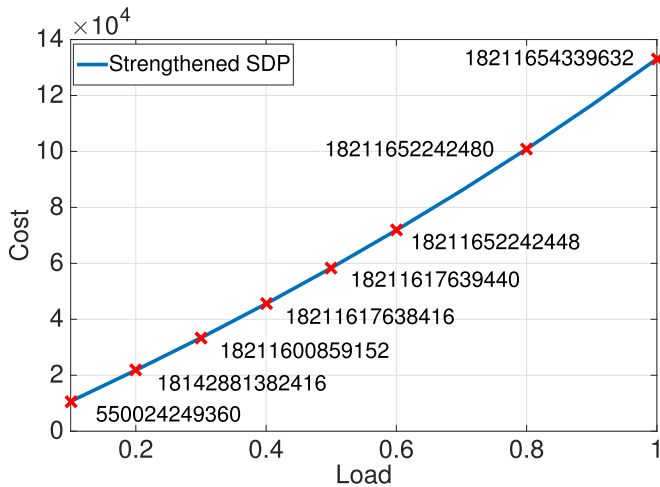

(a) Strengthened SDP

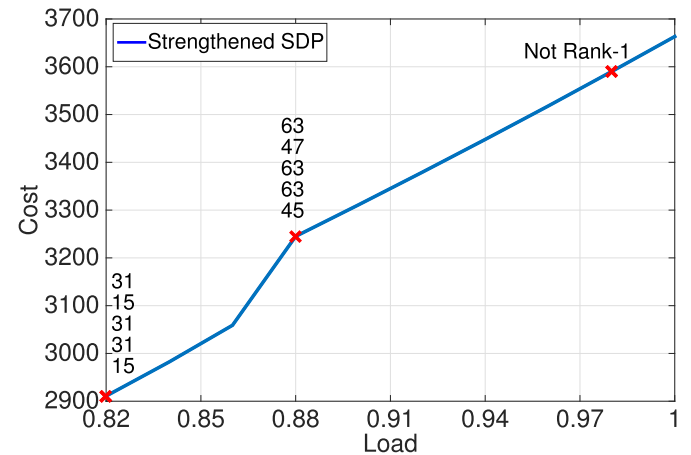

(a) Strengthened SDP

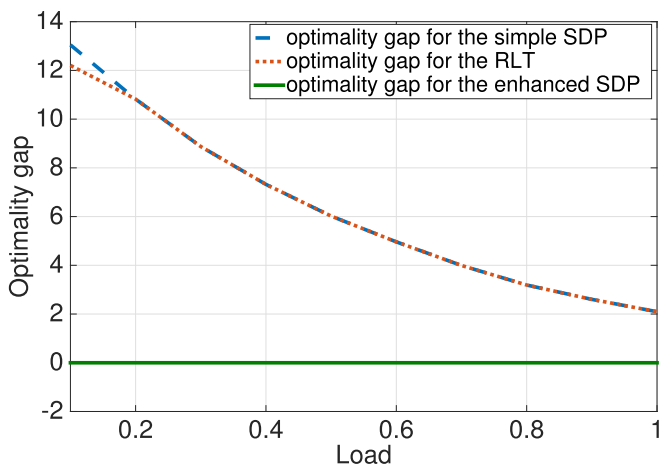

(b) Optimality Gap

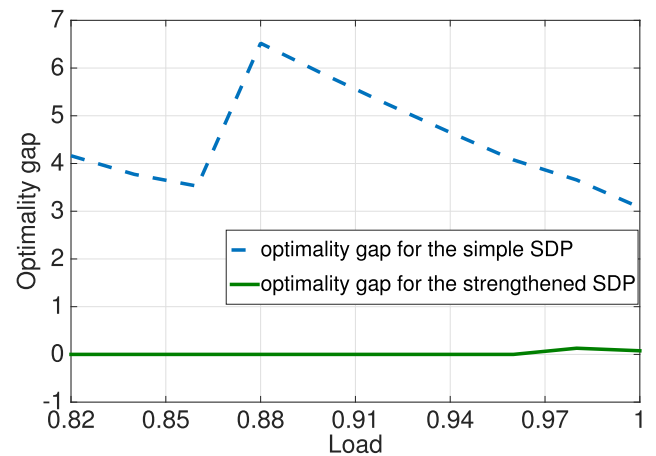

(b) Optimality Gap

Fig. D.10. 10 load scenarios for the IEEE 118-bus system with 54 generators over one time slot.

Fig. D.11. 10 load scenarios for the IEEE 30-bus system with 6 generators over  $t_0 = 5$  time slot.

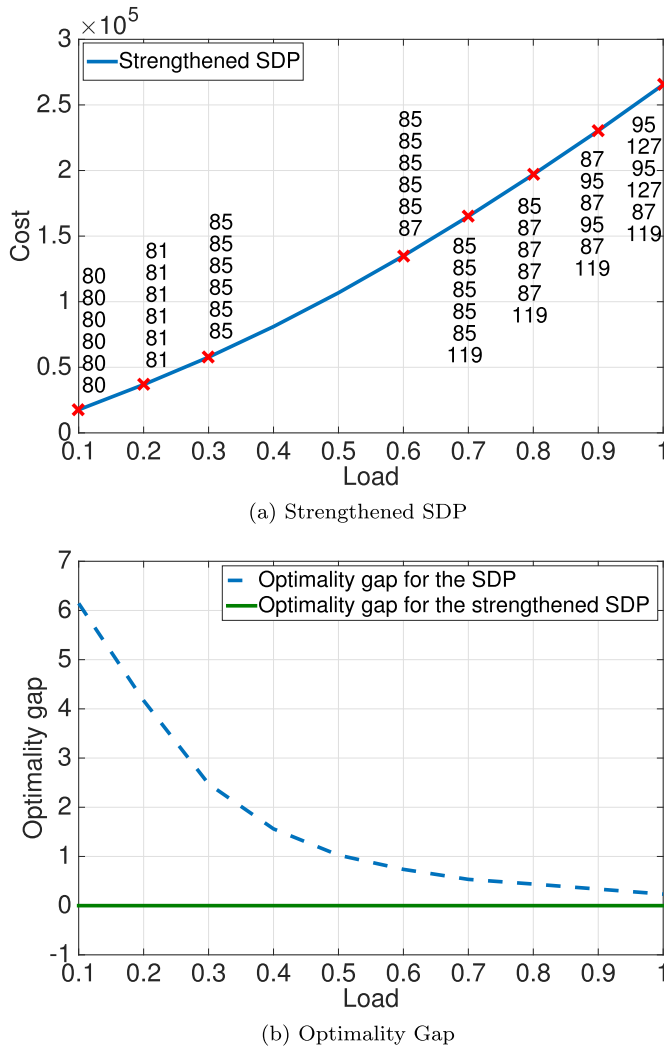

Fig. D.12. 10 load scenarios for the IEEE 57-bus system with 7 generators over  $t_0 = 6$  time slot.

optimal cost of the UC problem (found using Gurobi solver) and the optimal cost of the relaxation, respectively. The optimality gaps for the SDP, RLT and strengthened SDP relaxations are compared in Fig. D.2(b). Notice that the SDP and RLT relaxations perform very poorly and the proposed valid inequalities are essential for obtaining rank-1 (integer) solutions.

Fig. D.3 shows the performance of the proposed relaxations for different line ratings for the IEEE 9-bus system over one time slot ( $t_0 = 1$ ) with the load factor equal to 0.3. The uniform ratings of the

lines are chosen as  $\alpha_i = 30 + 5 \times i$  for  $i = 1, 2, \dots, 10$ . It can be observed that the strengthened SDP relaxation is exact in all scenarios. As rating of the lines decreases, the RLT relaxation becomes exact. This is due to the fact that the reliable lower bounds of the generators become strictly positive for small line ratings, which leads to the exactness of both RLT and strengthened SDP relaxations.

Fig. D.4 shows the solutions found by the strengthened SDP for 20 load scenarios for the IEEE 14-bus system with 5 generators over one time slot. The load factors are  $\alpha_i = 0.1 \times i$  for  $i = 1, 2, \dots, 20$ . The relaxation is exact in 19 load scenarios. More precisely, the load scenario  $\alpha_{18}$  is the only unsuccessful trial. As before, the proposed relaxation can retrieve the exact solution for this case after adding the triangle inequalities to the formulation.

The performance of the strengthened SDP relaxation with respect to different line ratings for the IEEE 14-bus system is reported in Fig. D.5. The uniform line ratings are  $\alpha_i = 15 + 5 \times i$  for  $i = 1, 2, \dots, 17$ , where the load factor is equal to 0.8. Except for  $\alpha_3$ , the proposed relaxation is exact for all line ratings.

Fig. D.6 illustrates the results of the strengthened SDP for 13 load scenarios for the IEEE 30-bus system with 6 generators over one time slot. The load factors are  $\alpha_i = 0.1 \times i$  for  $i = 1, 2, \dots, 13$ . It can be observed that the proposed convex relaxation is exact and finds the globally optimal solution of the problem for all scenarios. If the load factor is greater than or equal to 1.4, the UC problem becomes infeasible since the total load exceeds the total capacity of the generators.

Fig. D.7 depicts the performance of the strengthened SDP with respect to different line ratings for the IEEE 30-bus system. The load factor is equal to 0.7 and the uniform line ratings are chosen as  $\alpha_i = 15 + 5 \times i$  for  $i = 1, 2, \dots, 10$ . There is only one case (corresponding to  $\alpha_2$ ) for which the proposed relaxation is not exact.

Fig. D.8 shows the output of the strengthened SDP for 15 load scenarios for the IEEE 57-bus system with 7 generators over one time slot. The load factors are  $\alpha_i = 0.1 \times i$  for  $i = 1, 2, \dots, 15$ . The proposed convex relaxation obtains the globally optimal solution of the problem for all scenarios. Furthermore, the UC problem becomes infeasible if the load factor is greater than or equal to 1.6 since the total load exceeds the total generation capacity. Furthermore, Fig. D.9 illustrates the performance of our proposed method for the IEEE 57-bus system with the uniform line ratings  $\alpha_i = 30 + 5 \times i$  for  $i = 1, 2, \dots, 10$ . The load factor is set to 0.5. As before, the proposed relaxation successfully recovers the exact solution for all tested cases.

Consider 10 load scenarios for the IEEE 118-bus system with 54 generators over one time slot. The load factors are  $\alpha_i = 0.1 \times i$  for  $i = 1, 2, \dots, 10$ . The results are plotted for the reduced-strengthened SDP problem in Fig. D.10.

Fig. D.11 illustrates the results of the reduced-strengthened SDP (15) with low-order conic constraints for 10 load scenarios for the

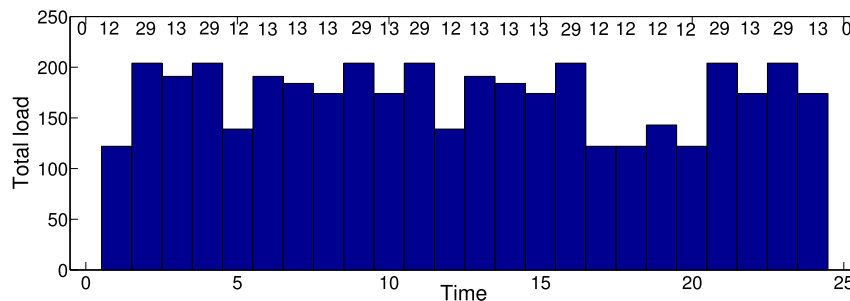

Fig. D.13. IEEE 14-bus system with 5 generators over 24 time slots.

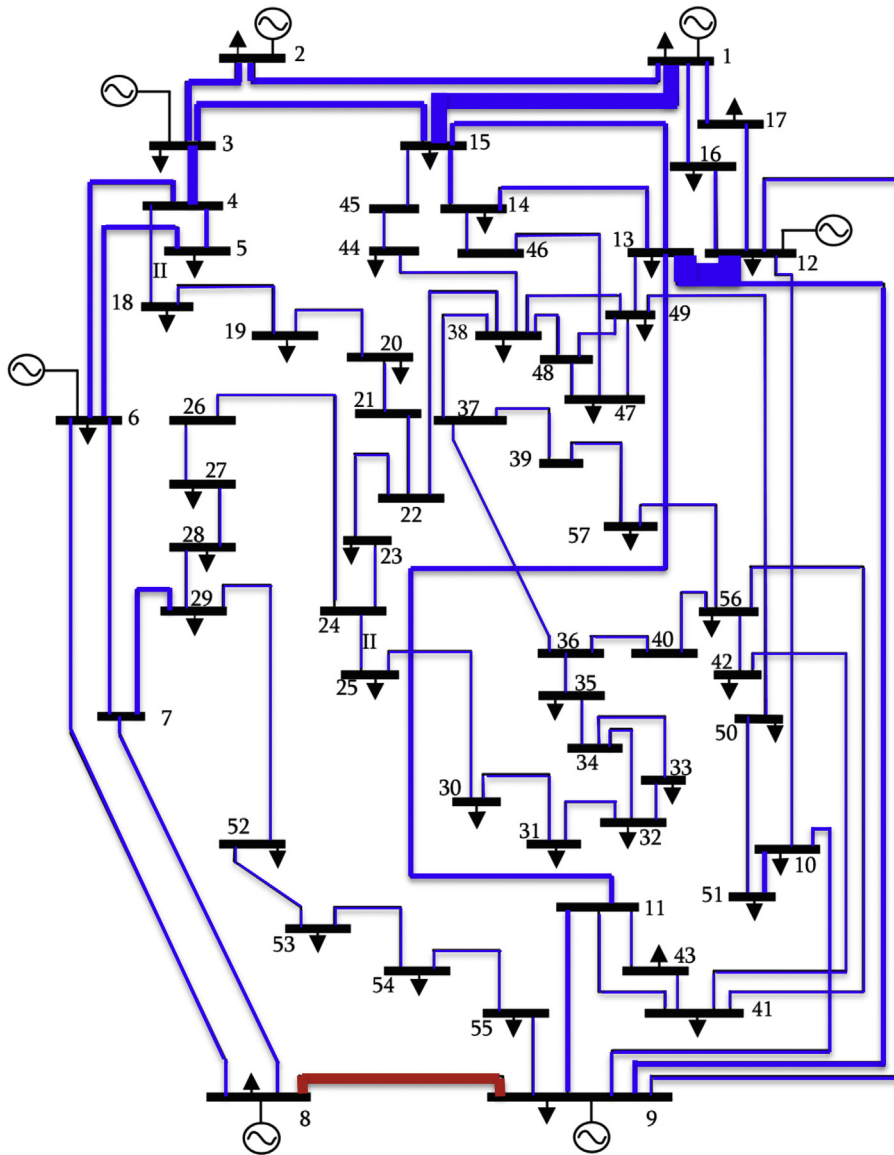

Fig. D.14. Weighted graph corresponding to Lagrange multipliers of constraints for IEEE 57-bus system.

IEEE 30-bus system with 6 generators over  $t_0 = 5$  time slots. The load factors are  $\alpha_i = 0.8 + 0.02 \times i$  for  $i = 1, 2, \dots, 10$ . Observe that reduced-strengthened SDP relaxation fails in only two cases. For these two cases, the optimality gap is close to zero. Note that each red cross in Fig. D.11a is accompanied by a vertical array of 5 numbers, each showing the commitment parameters (in base 10) for different time instances. Fig. D.12 shows the solutions of the relaxed strengthened SDP (15) for 10 load scenarios for the IEEE 57-bus system with 7 generators over 6 time slots. The load factors are  $\alpha_i = 0.1 \times i$  for  $i = 1, 2, \dots, 10$ . The proposed relaxation is exact for all load scenarios.

Consider the IEEE 300-bus system with 69 generators over one time slot and for the single load factor of 1. The strengthened SDP relaxation achieves the global minimum of the UC problem. The number natural 18338481760792186850 encodes the optimal statuses of all generators in base 10. After converting this number to a binary vector, it can be observed that 53 generators are on and 16 generators are off at optimality.

Next, consider the IEEE 14-bus system with 5 generators over 24 time slots. As before, the proposed convex model (25) achieves the

globally optimal solution of the UC problem for this scenario. Fig. D.13 displays the total load distribution over this horizon. Furthermore, the integer number on top of each column represents the optimal configuration of the generators at the corresponding time slot. The optimal cost associated with the reduced-strengthened SDP relaxation is 205838. However, the optimal cost for the SDP relaxation without the proposed valid inequalities is equal to 162600.

Finally, we aim to show that even if two lines are far from each other in the network, they may still generate a valid inequality that is crucial in finding a globally optimal solution of the UC problem. To this end, consider the IEEE 57-bus system with the load factor 0.5 and the uniform line rating equal to 35 over one time slot (for convenience, we drop the subscript  $t$ ). At optimality, the lines (8, 9), (1, 15), (7, 8), and (12, 13) are congested. We solve the strengthened SDP relaxation and consider the Lagrange multipliers corresponding to the valid inequalities



$$\begin{aligned} & \mathbf{H}_8 \mathbf{C}_g \mathbf{W}_{33} \mathbf{C}_g^\top \mathbf{H}_i^\top - (\mathbf{H}_i \mathbf{d} + f_{i,\max}) \mathbf{H}_8 \mathbf{C}_g \mathbf{w}_{31} - (\mathbf{H}_8 \mathbf{d} \\ & + f_{8,\max}) \mathbf{H}_i \mathbf{C}_g \mathbf{w}_{31} + (\mathbf{H}_i \mathbf{d} + f_{i,\max}) (\mathbf{H}_8 \mathbf{d} + f_{8,\max}) \\ & \geq 0 \end{aligned} \quad (16)$$

for  $i = 1, 2, \dots, n_l$ . The above inequalities correspond to the multiplication of the flow constraints of the line (8, 9) and every line of the network, i.e.,  $\mathbf{H}_8(\mathbf{d} - \mathbf{C}_g \mathbf{p}) + f_{8,\max} \geq 0$  and  $\mathbf{H}_i(\mathbf{d} - \mathbf{C}_g \mathbf{p}) + f_{i,\max} \geq 0$ . Note that the number 8 is the index of those rows of  $\mathbf{H}$  and  $\mathbf{f}_{\max}$  that are associated with the line (8, 9). The magnitudes of the optimal Lagrange multipliers corresponding to the constraints in (16) are visualized as a weighted graph in Fig. D.14. The thickness (weight) of each blue line is proportional to the magnitude of the optimal Lagrange multiplier for the valid inequality obtained by multiplying the flow constraints of that line and the red line (8, 9). The weights are normalized with respect to the largest magnitude of the Lagrange multipliers. Recall that Lagrange multipliers show the sensitivity of the optimal objective value of the strengthened SDP problem to infinitesimal perturbations. It can be observed that the largest Lagrange multiplier corresponds to the line (12, 13) that is far from the line (8, 9). Moreover, Fig. D.14 shows that even though generators 1, 2 and 3 are distant from the line (8, 9), the valid inequalities generated by their adjacent lines (paired with (8, 9)) are important.

## 5. Conclusion and future works

Finding a global minimum of the unit commitment (UC) problem, as a mixed-integer nonlinear optimization problem, for DC models of power systems is a daunting challenge due to its inherent complexity. Although this problem may be solved for several practical instances using different heuristic or highly complex methods developed in the literature, there is no known tight convex model of a polynomial size for real-world cases of the UC problem. The objective of this paper is to address this issue by developing a convex model that is tight for most practical instances. Our approach is based on developing a convex conic relaxation for the UC problem. This is achieved by generating valid nonlinear constraints and then relaxing them to linear matrix inequalities. These valid inequalities are obtained by the multiplication of the linear constraints of the UC problem, such as the flow constraints of two different lines. The proposed technique is extensively tested on benchmark systems to show that, except for very few cases, this method correctly finds a globally optimal schedule of the generators for a wide range of load profiles and line ratings. The significance of the proposed method compared to the existing techniques lies in the fact that it provides a solution whose global optimality can be certified. Furthermore, the proposed model can be solved efficiently due to its convexity. The designed convex model can be readily employed for the convex-hull pricing scheme, where the objective is to design a uniform price in energy market that minimizes the uplift payments to the generating units. The performance of the method developed in this paper is showcased on different IEEE benchmark systems, including IEEE 9-bus, IEEE 14-bus, IEEE 30-bus, IEEE 57-bus, IEEE 118-bus, and IEEE 300-bus systems.

The proposed technique can be generalized to handle the AC model of power systems that is known to be highly nonlinear and nonconvex. Recent results show that the AC model of power flow equations could be described by an SDP formulation in a large set of scenarios. As future work, we will investigate the UC problem for an AC model of power systems by combining two SDP formulations, one taking care of the discrete variables of UC and another one

accounting for the continuous nonlinearity of the power flow equations.

## Acknowledgment

This work was supported by DARPA YFA, ONR YIP Award, AFOSR YIP Award, NSF CAREER Award 1351279 and NSF EECS Award 1406865. A. Atamtürk was supported, in part, by grant FA9550-10-1-0168 from the Office of the Assistant Secretary of Defense for Research and Engineering.

## Appendix A. Equivalence of SDP and QP relaxations

**Theorem 1.** *The optimal objective values of the SDP relaxation (9) and the basic QP relaxation of the UC problem are the same if  $t_0 = 1$ .*

*Proof.* Assume that  $(\mathbf{w}^*, \mathbf{W}^*)$  denotes an optimal solution of the SDP relaxation (9). First, we aim to show that  $\mathbf{w}^*$  is a feasible point of the basic QP relaxation. Consider an index  $k$  corresponding to an element of  $\mathbf{w}$  associated with a generator status. The constraint (9b) is the same as (7b). Moreover, (9d) implies that  $W_{kk}^* \geq w_k^{*2}$ , which together with the constraint (9c) leads to the relation  $0 \leq w_k^* \leq 1$ . As a result,  $\mathbf{w}^*$  is a point feasible for the basic QP problem. Due to the definitions of  $c_r(\mathbf{w}, \mathbf{W})$  and  $c(\mathbf{w})$  as well as the inequality  $W_{kk}^* \geq w_k^{*2}$ , one can verify that  $c_r(\mathbf{w}^*, \mathbf{W}^*) \geq c(\mathbf{w}^*)$ . Therefore, the optimal cost of the SDP relaxation is greater than or equal to the cost of the QP relaxation.

In order to complete the proof, it suffices to show that the optimal cost of the QP relaxation is greater than or equal to the optimal cost of the SDP relaxation. Suppose that  $\hat{\mathbf{w}}$  denotes an optimal solution of the QP relaxation of the UC problem. One can build a matrix  $\hat{\mathbf{W}}$  such that  $(\hat{\mathbf{w}}, \hat{\mathbf{W}})$  is a feasible point for the SDP relaxation with a cost equal to the optimal cost of the QP relaxation. The constraint (9b) is a reformulation of the linear constraints and therefore it holds true. Furthermore, the constraint  $0 \leq \hat{w}_k \leq 1$  implies that  $\hat{w}_k^2 \leq \hat{w}_k$ . Therefore, we can construct a non-negative diagonal matrix  $\mathbf{W}_0$  such that  $(\hat{\mathbf{W}}_{0kk} + \hat{w}_k^2) - \hat{w}_k = 0$ . As a result,  $(\hat{\mathbf{w}}, \hat{\mathbf{W}})$  is feasible for SDP relaxation, where  $\hat{\mathbf{W}} = \hat{\mathbf{w}}\hat{\mathbf{w}}^\top + \mathbf{W}_0$ . Note that the only possibly required positive elements of  $\mathbf{W}_0$  are the diagonal elements corresponding to the statuses of generators. Furthermore, notice that these diagonal elements do not appear in the objective whenever  $t_0 = 1$ . Therefore, one can verify that  $c_r(\hat{\mathbf{w}}, \hat{\mathbf{W}}) = c(\hat{\mathbf{w}})$ . This completes the proof.

## Appendix B. Decomposition of the conic constraint

**Theorem 2.** *The conic constraint  $\mathbf{W} \succeq \mathbf{w}\mathbf{w}^\top$  in the relaxation of the strengthened SDP problem, i.e., (15), is equivalent to the following set of smaller conic constraints:*

$$\mathbf{W}\{\mathcal{V}_t, \mathcal{V}_t\} \succeq \mathbf{w}\{\mathcal{V}_t\}\mathbf{w}\{\mathcal{V}_t\}^\top, \quad t = 1, 2, \dots, t_0 \quad (\text{B.1})$$

*in the absence of minimum up- and down-time constraints.*

*Proof.* Assume that the minimum up- and down-time constraints do not exist. It can be observed that in (15b), (15c), and (15d), the decision variables at each time instance are coupled only with the decision variables of the next and previous time slots. Using the chordal extension technique (see Ref. [57]), it is easy to verify that relaxing the constraint (15e) to (B.1) does not affect the optimal cost. This is due to the fact that the tree decomposition of the above problem is a path. The details are omitted for brevity.

**Appendix C. Exactness of RLT and strengthened SDP relaxations**

In this section, we will show that large load factors and small line ratings can both make the RLT and strengthened SDP relaxations exact. The exactness is due to the added valid inequalities and the SDP relaxation without these valid inequalities is not exact in general. To streamline the presentation, we assume that  $t_0 = 1$  and then drop the subscript  $t$  from the formulation. The results can easily be extended to the case  $t_0 > 1$ . Define  $\widehat{\mathbf{W}}$  as

$$\widehat{\mathbf{W}} = \begin{bmatrix} 1 & \mathbf{w}^\top \\ \mathbf{w} & \mathbf{W} \end{bmatrix} = \begin{bmatrix} 1 & \mathbf{w}_{21}^\top & \mathbf{w}_{31}^\top \\ \mathbf{w}_{21} & \mathbf{W}_{22} & \mathbf{W}_{32} \\ \mathbf{w}_{31} & \mathbf{W}_{32} & \mathbf{W}_{33} \end{bmatrix}. \tag{C.1}$$

Note that  $\mathbf{w}_{21}$  and  $\mathbf{w}_{31}$  correspond to  $\mathbf{x}$  and  $\mathbf{p}$ , and that  $\mathbf{W}_{22}$ ,  $\mathbf{W}_{32}$  and  $\mathbf{W}_{33}$  correspond to  $\mathbf{x}\mathbf{x}^\top$ ,  $\mathbf{p}\mathbf{x}^\top$  and  $\mathbf{p}\mathbf{p}^\top$  in the conic relaxation of the non-convex constraint  $\mathbf{W} = \mathbf{w}\mathbf{w}^\top$ .

Consider the last 4 sets of inequalities in  $\mathbf{M}\mathbf{w} \geq \mathbf{m}$  corresponding to the last  $2n_l + 2$  rows of  $\mathbf{M}$  and  $\mathbf{m}$  in (8). It is straightforward to verify that these constraints together with the constraint  $0 \leq \mathbf{w}_{31} \leq \mathbf{p}_{\max}$  define a bounded polytope, denoted as  $\mathcal{P}_l$ , which is a convex relaxation of the feasible region of  $\mathbf{p}$  in (3). It is clear that  $p_{i,\min} \leq p_{i,\max}$  for every  $i \in \mathcal{G}$  (otherwise, the UC problem is infeasible). Moreover, the output of a generator is normally nonnegative (otherwise, it will consume electricity). Due to these reasons, assume that  $0 \leq p_{i,\min} < p_{i,\max}$ . In the rest of this subsection, we make the practical assumption that the fixed and start-up costs of all generators are strictly positive.

**Definition 1.** For every  $i \in \{1, 2, \dots, n_g\}$ , define the reliable lower bound  $l^i$  and the reliable upper bound  $u^i$  of generator  $i$  as

$$\begin{aligned} l^i &= \underset{\mathbf{w}_{31} \in \mathcal{P}_l}{\text{minimize}} w_{31}^i, \\ u^i &= \underset{\mathbf{w}_{31} \in \mathcal{P}_l}{\text{maximize}} w_{31}^i. \end{aligned} \tag{C.2}$$

Moreover, define  $\mathbf{l}$  and  $\mathbf{u}$  as the vectors  $[l^1, l^2, \dots, l^{n_g}]$  and  $[u^1, u^2, \dots, u^{n_g}]$ , respectively.

Define  $\mathcal{G}^+$  as the index set of generators with strictly positive reliable lower bounds.

**Theorem 3.** Let  $(\mathbf{w}, \mathbf{W})$  denote an arbitrary feasible solution of the RLT or strengthened SDP relaxation, and  $\mathbf{x}^{\text{opt}}$  denote an arbitrary globally optimal commitment of generators in the UC problem. Furthermore, let  $(\widehat{\mathbf{w}}, \widehat{\mathbf{W}})$  denote an optimal solution of the SDP relaxation. The following statements hold for every  $i \in \mathcal{G}^+$ :

- (i)  $w_{21}^i = x_i^{\text{opt}} = 1$ .
- (ii)  $\overline{w}_{21}^i \neq x_i^{\text{opt}}$  if  $u^i < p_{i,\max}$ .

*Proof.* The set  $\mathcal{P}_l$  can be described as  $\mathbf{M}_l \mathbf{w}_{31} \geq \mathbf{m}_l$ , where

$$\mathbf{M}_l = \begin{bmatrix} \mathbf{I}_{n_g \times n_g} \\ -\mathbf{I}_{n_g \times n_g} \\ \mathbf{1}_{1 \times n_g} \\ -\mathbf{1}_{1 \times n_g} \\ \mathbf{H} \cdot \mathbf{C}_g \\ -\mathbf{H} \cdot \mathbf{C}_g \end{bmatrix}, \quad \mathbf{m}_l = \begin{bmatrix} \mathbf{0}_{n_g \times 1} \\ -\mathbf{p}_{\max} \\ \sum_{j=1}^{n_b} d_j \\ -\sum_{j=1}^{n_b} d_j \\ \mathbf{H} \cdot \mathbf{d} - \mathbf{f}_{\max} \\ -\mathbf{H} \cdot \mathbf{d} - \mathbf{f}_{\max} \end{bmatrix}.$$

Therefore, one can rewrite  $\mathbf{M}$  and  $\mathbf{m}$  as

$$\mathbf{M} = \begin{bmatrix} \mathbf{M}_1 \\ \mathbf{M}_2 \\ \mathbf{M}_3 \\ \mathbf{M}_4 \\ \mathbf{M}_5 \end{bmatrix} = \begin{bmatrix} \mathbf{I}_{n_g} & \mathbf{0}_{n_g \times n_g} \\ -\mathbf{I}_{n_g} & \mathbf{0}_{n_g \times n_g} \\ -\text{diag}\{\mathbf{p}_{\min}\} & \mathbf{I}_{n_g} \\ \text{diag}\{\mathbf{p}_{\max}\} & -\mathbf{I}_{n_g} \\ \mathbf{0}_{(2n_l+2n_g+2) \times n_g} & \mathbf{M}_l \end{bmatrix}, \quad \mathbf{m} = \begin{bmatrix} \mathbf{m}_1 \\ \mathbf{m}_2 \\ \mathbf{m}_3 \\ \mathbf{m}_4 \\ \mathbf{m}_5 \end{bmatrix} = \begin{bmatrix} \mathbf{0}_{n_g \times 1} \\ -\mathbf{1}_{n_g \times 1} \\ \mathbf{0}_{n_g \times 1} \\ \mathbf{0}_{n_g \times 1} \\ \mathbf{m}_l \end{bmatrix}. \tag{C.3}$$

For notational simplicity, define

$$\mathbf{L}_{\{ij\}} = \mathbf{M}_i \mathbf{W} \mathbf{M}_j^\top - \mathbf{m}_i \mathbf{w}^\top \mathbf{M}_j^\top - \mathbf{M}_i \mathbf{w} \mathbf{m}_j^\top + \mathbf{m}_i \mathbf{m}_j^\top, \tag{C.4}$$

for every  $i, j \in \{1, \dots, 5\}$ . Furthermore,  $\mathbf{L}_{\{ij\}}^{m,n}$  will be used to refer to the  $(m, n)$ <sup>th</sup> element of the matrix  $\mathbf{L}_{\{ij\}}$ .

First, we prove Part (i) using a particular set of valid inequalities introduced by (12c). It follows from  $\mathbf{L}_{\{3,2\}}^{ij} \geq 0$  that

$$-p_{i,\min} w_{21}^i + w_{31}^i + p_{i,\min} W_{22}^{ij} - W_{32}^{ij} \geq 0, \tag{C.5}$$

or equivalently,

$$p_{i,\min} (w_{21}^i - W_{22}^{ij}) \leq w_{31}^i - W_{32}^{ij}, \tag{C.6}$$

for every  $i, j \in \{1, 2, \dots, n_g\}$ . Likewise, the inequality  $\mathbf{L}_{\{4,2\}}^{ij} \geq 0$  leads to

$$w_{31}^i - W_{32}^{ij} \leq p_{i,\max} (w_{21}^i - W_{22}^{ij}), \tag{C.7}$$

for every  $i, j \in \{1, 2, \dots, n_g\}$ . If  $i = j$ , combining (C.6) and (C.7) with the constraint  $w_{21}^i = W_{22}^{ii}$  yields that

$$w_{31}^i = W_{32}^{ii}. \tag{C.8}$$

Consider the constraints  $\mathbf{w}_{31} \geq \mathbf{l}$  and  $\mathbf{u} \geq \mathbf{w}_{31}$ , which are implied by  $\mathbf{M}\mathbf{w} \geq \mathbf{m}$ . Moreover, consider the following inequalities for every  $i \in \{1, 2, \dots, n_g\}$ :

$$u^i - w_{31}^i - u^i w_{21}^i + W_{32}^{ii} \geq 0, \tag{C.9a}$$

$$-l^i + w_{31}^i + u^i w_{21}^i - W_{32}^{ii} \geq 0. \tag{C.9b}$$

These valid inequalities are generated by multiplying  $w_{31}^i - l^i \geq 0$  and  $u^i - w_{31}^i \geq 0$  with  $1 - w_{21}^i \geq 0$ . According to [43], one can show that adding (C.9a) and (C.9b) to the formulation does not change the feasible region of the RLT relaxation (and as a result, the strengthened SDP) since they are implied by other added valid inequalities. However, one can combine (C.8) with (C.9a) and (C.9b) to arrive at

$$u^i (1 - w_{21}^i) \geq 0, \tag{C.10a}$$

$$l^i (w_{21}^i - 1) \geq 0. \tag{C.10b}$$

Since  $i \in \mathcal{G}^+$ , we have  $0 < l^i \leq u^i$ . Therefore, (C.10) implies that  $w_{21}^i = 1$ . Furthermore, it can be inferred from  $0 < l^i$  that  $x_i^{\text{opt}} = 1$ . This completes the proof of Part (i).

Next, we prove Part (ii). Notice that according to Theorem 1, the SDP relaxation is equivalent to the QP relaxation whenever  $t_0 = 1$ . Since  $w_{21}^i$  appears in the objective function of the SDP relaxation with a positive coefficient, it can be deduced that

$$\bar{w}_{21}^i = \frac{\bar{w}_{31}^i}{p_{i,\max}}, \quad (\text{C.11})$$

for every  $i \in \mathcal{G}$ . This implies that  $\bar{w}_{21}^i \in \{0, 1\}$  if and only if  $\bar{w}_{31}^i \in \{0, p_{i,\max}\}$ . However, it is easy to verify that since  $u^i < p_{i,\max}$  by assumption, the inequalities  $0 < l^i \leq \bar{w}_{31}^i \leq u^i < p_{i,\max}$  hold. The proof follows from (C.11).

**Corollary 1.** *The SDP relaxation (9) is not exact if there does not exist a globally optimal solution  $(\mathbf{x}^{\text{opt}}, \mathbf{p}^{\text{opt}})$  of the UC problem such that  $p_i^{\text{opt}} \in \{0, p_{i,\max}\}$  for every  $i \in \mathcal{G}$ .*

*proof.* Let  $(\bar{\mathbf{w}}, \bar{\mathbf{W}})$  denote an arbitrary solution of the SDP relaxation. Assume that  $p_i^{\text{opt}} \notin \{0, p_{i,\max}\}$  for some index  $i \in \mathcal{G}$ . Due to the proof of Theorem 3, this means that  $\bar{w}_{21}^i \notin \{0, 1\}$ . As a result,  $(\mathbf{x}^{\text{opt}}, \mathbf{p}^{\text{opt}})$  does not correspond to a global minimum of the UC problem. This implies that the SDP relaxation is not exact.

**Remark 6.** Theorem 3 states that, regardless of the objective functions of the RLT and strengthened SDP relaxations, the added valid inequalities ensure that the relaxation correctly finds the optimal statuses of those generators whose reliable lower bounds are strictly positive. Furthermore, it unveils that a global minimum of the UC problem might be recoverable by the SDP relaxation (without valid inequalities) only in the scenario where each generator is turned off or operates at its maximum capacity at an optimal solution of the UC problem. By fixing the limits  $p_{i,\max}$  for every  $i \in \mathcal{G}$ , the previous statement implies that although  $\mathbf{d}$  could take infinitely many values, only a finite number of them would make the SDP relaxation exact (because  $\sum_{j \in \mathcal{B}} d_j$  is equal to the summation of a subset of the limits  $p_{i,\max}$ 's in the exact SDP case). This shows the clear difference between the SDP and strengthened SDP relaxation.

One may speculate that the performance of the strengthened SDP and RLT relaxations could be increased by first identifying generators with nontrivial positive lower bounds on their productions (via bound tightening on  $\mathbf{M}_l \mathbf{w}_{31} \geq \mathbf{m}_l$ ) and then setting their corresponding binary variables to 1. Theorem 3 shows that this is indeed not the case since this process is automatically incorporated in the above relaxations. For every  $i \in \mathcal{B}$ , let  $\mathcal{N}_1(i)$  denote the set of lines that are connected to bus  $i$ . Furthermore, for every  $j \in \mathcal{G}$ , define  $\mathcal{S}_j$  as the index set of those generators that are connected to the same bus as generator  $j$ .

**Theorem 4.** *Suppose that the UC problem is feasible, and that either of the following conditions is satisfied:*

**Condition 1.** *For every generator  $j \in \mathcal{G}$ , the relation*

$$d_j - \text{maximize} \left\{ \sum_{i \in \mathcal{S}_j \setminus k} p_{i,\max} \right\} > \sum_{k \in \mathcal{N}_1(b_j)} f_{k,\max} \quad (\text{C.12})$$

holds, where  $b_j$  denotes the bus adjacent to generator  $j$ .

**Condition 2.** *The relation*

$$\sum_{j \in \mathcal{B}} d_j > \text{maximize}_{k \in \mathcal{S}} \left\{ \sum_{i \in \mathcal{S} \setminus k} p_{i,\max} \right\} \quad (\text{C.13})$$

holds.

Then, the RLT and strengthened SDP relaxations of the UC problem are both exact. However, the SDP relaxation is exact only when

$$\sum_{j \in \mathcal{B}} d_j = \sum_{i \in \mathcal{S}} p_{i,\max}. \quad (\text{C.14})$$

*Proof.* Assume that either of Conditions 1 and 2 is satisfied. It can be verified that  $l^i > 0$  for every  $i \in \mathcal{G}$ , which yields that  $\mathcal{S}^+ = \mathcal{S}$ . Now, it follows from Theorem 3 that the RLT and strengthened SDP relaxations are both exact. Furthermore, if  $(\mathbf{x}^{\text{opt}}, \mathbf{p}^{\text{opt}})$  denotes a globally optimal solution of the UC problem, then  $p_i^{\text{opt}} \geq l^i > 0$  for every  $i \in \mathcal{G}$ . Therefore, it results from Corollary 1 that the SDP relaxation could possibly be exact only when  $p_i^{\text{opt}} = p_{i,\max}$  for all  $i \in \mathcal{G}$ , which lead to equation (C.14).

Consider the case where there are not any two generators connected to the same bus. It can be inferred from Theorem 4 that large load factors and/or small line ratings both result in the exactness of the RLT and strengthened SDP relaxations.

## Appendix D. Elimination of redundant valid inequalities

In this section, we aim to reduce the number of added valid inequalities by identifying a subset of redundant (implied) constraints and removing them from the formulation. We assume that  $t_0 = 1$  and drop the subscript  $t$  from the formulation. However, the results can easily be extended to the case  $t_0 > 1$ . According to the definition of the matrix  $\mathbf{M}$  in (8), the number of linear inequalities in the strengthened SDP problem is equal to

$$\underbrace{4n_g + 2n_l + 2}_{(12b)} + \underbrace{(4n_g + 2n_l + 2)^2}_{(12c)} + \underbrace{n_g}_{(12d)} \\ = 4n_l^2 + 16n_g^2 + 16n_g n_l + 21n_g + 10n_l + 6. \quad (\text{D.1})$$

On the other hand, since (12c) is symmetric, the constraints corresponding to the lower triangular part of (12c) are redundant and can be removed. The number of remaining constraints amounts to

$$\frac{(4n_g + 2n_l + 2)^2 + (4n_g + 2n_l + 2)}{2} + 4n_g + 2n_l + 2 + n_g \\ = 2n_l^2 + 8n_g^2 + 8n_g n_l + 15n_g + 7n_l + 5. \quad (\text{D.2})$$

**Lemma 1.** *The constraint  $x_i \geq 0$  is implied by the inequalities  $p_{i,\min} \times x_i \leq p_i \leq p_{i,\max} \times x_i$ , for every  $i \in \{1, \dots, n_g\}$ .*

Notice that Lemma 1 immediately follows from the relation  $p_{i,\min} < p_{i,\max}$ .

**Lemma 2.** (12b) is implied by (12c).

*Proof.* The proof can be found in Ref. [43].

Using Lemmas 1 and 2, the number of potentially required linear inequalities will be reduced to  $2n_l^2 + 4.5n_g^2 + 6n_g n_l + 8.5n_g + 5n_l + 3$ .

## References

- [1] Guan X, Zhai Q, Papalexopoulos A. Optimization based methods for unit commitment: lagrangian relaxation versus general mixed integer programming. In: IEEE power engineering society general meeting, vol. 2; 2003.
- [2] Padhy NP. Unit commitment - a bibliographical survey. IEEE Trans Power Syst 2004;19(2):1196–205.
- [3] Hobbs BF. The next generation of electric power unit commitment models, vol. 36. Springer Science & Business Media; 2001.
- [4] Ongsakul W, Petcharak N. Unit commitment by enhanced adaptive lagrangian relaxation. IEEE Trans Power Syst 2004;19(1):620–8.
- [5] Dubost L, Gonzalez R, Lemaréchal C. A primal-proximal heuristic applied to the French unit-commitment problem. Math Program 2005;104(1):129–51.
- [6] Gollmer R, Nowak MP, Römisch W, Schultz R. Unit commitment in power generation—a basic model and some extensions. Ann Operations Res 2000;96(1–4):167–89.
- [7] Bai Y, Zhong H, Xia Q, Kang C, Xie L. A decomposition method for network-constrained unit commitment with AC power flow constraints. Energy

- 2015;88:595–603.
- [8] Turgeon A. Optimal unit commitment. *IEEE Trans Automatic Control* 1977;22(2):223–7.
  - [9] Rajan D, Takriti S. Minimum up/down polytopes of the unit commitment problem with start-up costs. 2005 [cited 5/15/2017]. URL, <https://pdfs.semanticscholar.org/b886/42e36b414d5929fed48593d0ac46ae3e2070.pdf>.
  - [10] Garver LL. Power generation scheduling by integer programming—development of theory, Power Apparatus and Systems, Part III. *Trans Am Inst Electr Eng* 1962;81(3):730–4.
  - [11] Morales-Espana G, Latorre JM, Ramos A. Tight and compact MILP formulation of start-up and shut-down ramping in unit commitment. *IEEE Trans Power Syst* 2013;28(2):1288–96.
  - [12] O’Neill RP, Hedman KW, Krall EA, Papavasiliou A, Oren SS. Economic analysis of the n-1 reliable unit commitment and transmission switching problem using duality concepts. *Energy Syst* 2010;1(2):165–95.
  - [13] O’Neill RP, Krall EA, Hedman KW, Oren SS. A model and approach to the challenge posed by optimal power systems planning. *Math Program* 2013;140(2):239–66.
  - [14] Ostrowski J, Anjos MF, Vannelli A. Tight mixed integer linear programming formulations for the unit commitment problem. *IEEE Trans Power Syst* 2012;27(1):39.
  - [15] Damcı-Kurt P, Küçükayavuz S, Rajan D, Atamtürk A. A polyhedral study of production ramping. *Math Program* 2016;158(1):175–205.
  - [16] Muckstadt JA, Koenig SA. An application of lagrangian relaxation to scheduling in power-generation systems. *Operations Res* 1977;25(3):387–403.
  - [17] Papavasiliou A, Oren SS. Multiarea stochastic unit commitment for high wind penetration in a transmission constrained network. *Operations Res* 2013;61(3):578–92.
  - [18] Ji B, Yuan X, Chen Z, Tian H. Improved gravitational search algorithm for unit commitment considering uncertainty of wind power. *Energy* 2014;67:52–62.
  - [19] Liao G-C. A novel evolutionary algorithm for dynamic economic dispatch with energy saving and emission reduction in power system integrated wind power. *Energy* 2011;36(2):1018–29.
  - [20] Lorca A, Sun XA, Litvinov E, Zheng T. Multistage adaptive robust optimization for the unit commitment problem. *Operations Res* 2016;64(1):32–51.
  - [21] Cerisola S, Baíllo Á, Fernández-López JM, Ramos A, Gollmer R. Stochastic power generation unit commitment in electricity markets: a novel formulation and a comparison of solution methods. *Operations Res* 2009;57(1):32–46.
  - [22] Philpott A, Schultz R. Unit commitment in electricity pool markets. *Math Program* 2006;108(2–3):313–37.
  - [23] Nikzad M, Mozafari B, Bashirvand M, Solaymani S, Ranjbar AM. Designing time-of-use program based on stochastic security constrained unit commitment considering reliability index. *Energy* 2012;41(1):541–8.
  - [24] Yang Y, Yang N, Wang B, Han X, Bian C. Security constrained unit commitment incorporating volatile wind power. *IEEE Int Conf Power Syst Technol* 2014: 844–51.
  - [25] Ferruzzi G, Cervone G, Monache LD, Graditi G, Jacobone F. Optimal bidding in a day-ahead energy market for micro grid under uncertainty in renewable energy production. *Energy* 2016;106:194–202.
  - [26] Frangioni A, Gentile C. Solving nonlinear single-unit commitment problems with ramping constraints. *Operations Res* 2006;54(4):767–75.
  - [27] Madrigal M, Quintana VH. An interior-point/cutting-plane method to solve unit commitment problems. In: *Proceedings of the 21st IEEE international conference power industry computer applications (PICA)*; 1999. p. 203–9.
  - [28] Jabr RA. Tight polyhedral approximation for mixed-integer linear programming unit commitment formulations. *IET Gener Transm & Distribution* 2012;6(11):1104–11.
  - [29] Bai X, Wei H, Fujisawa K, Wang Y. Semidefinite programming for optimal power flow problems. *Int J Electr Power & Energy Syst* 2008;30(6):383–92.
  - [30] Lavaei J, Low SH. Zero duality gap in optimal power flow problem. *IEEE Trans Power Syst* 2012;27(1):92–107.
  - [31] Sojoudi S, Lavaei J. Physics of power networks makes hard optimization problems easy to solve. *IEEE Power and Energy Society General Meeting*; 2012. p. 1–8.
  - [32] Fariivar M, Low SH. Branch flow model: relaxations and convexification—Part I. *IEEE Trans Power Syst* 2013;28(3):2554–64.
  - [33] Lavaei J, Tse D, Zhang B. Geometry of power flows and optimization in distribution networks. *IEEE Trans Power Syst* 2014;29(2):572–83.
  - [34] Tan CW, Cai DWH, Lou X. Resistive network optimal power flow: uniqueness and algorithms. *IEEE Trans Power Syst* 2015;30(1):263–73.
  - [35] Madani R, Sojoudi S, Lavaei J. Convex relaxation for optimal power flow problem: mesh networks. *IEEE Trans Power Syst* 2015;30(1):199–211.
  - [36] Madani R, Ashraphijoo M, Lavaei J. Promises of conic relaxation for contingency-constrained optimal power flow problem. *IEEE Trans Power Syst* 2016;31(2):1297–307.
  - [37] C. Chen, A. Atamtürk, S. Oren, A spatial branch-and-cut method for nonconvex qcqp with bounded complex variables, *Mathematical Programming* <http://dx.doi.org/10.1007/s10107-016-1095-2>.
  - [38] Jozs C, Maeght J, Panciatici P, Gilbert JC. Application of the moment-sos approach to global optimization of the opf problem. *IEEE Trans Power Syst* 2015;30(1):463–70.
  - [39] M. Baradar, M. R. Hesamzadeh, M. Ghandhari, Second-order cone programming for optimal power flow in vsc-type ac-dc grids, *IEEE Trans Power Syst* 28, (4) (13) 4282–4291.
  - [40] Bahrami S, Therrien F, Wong VWS, Jatskevich J. Semidefinite relaxation of optimal power flow for ac–dc grids. *IEEE Trans Power Syst* 2017;32(1): 289–304.
  - [41] Bai X, Wei H. Semi-definite programming-based method for security-constrained unit commitment with operational and optimal power flow constraints. *IET Generation, Transm Distribution* 2009;3(2):182–97.
  - [42] Paredes M, Martins LSA, Soares S. Using semidefinite relaxation to solve the day-ahead hydro unit commitment problem. *IEEE Trans Power Syst* 2015;30(5):2695–705.
  - [43] Serali HD, Adams WP. A reformulation-linearization technique for solving discrete and continuous nonconvex problems, vol. 31. Springer Science & Business Media; 2013.
  - [44] R. Madani, G. Fazelnia, S. Sojoudi, J. Lavaei, Finding low-rank solutions of sparse linear matrix inequalities using convex optimization, to appear in *SIAM J Optim* <http://dx.doi.org/10.1137/14099379X>.
  - [45] Sojoudi S, Lavaei J. Exactness of semidefinite relaxations for nonlinear optimization problems with underlying graph structure. *SIAM J Optim* 2014;24(4):1746–78.
  - [46] Fazelnia G, Madani R, Kalbat A, Lavaei J. Convex relaxation for optimal distributed control problems. *IEEE Trans Automatic Control* 2017;62(1): 206–21.
  - [47] Atamtürk A, Berenguer G, Shen Z-J. A conic integer programming approach to stochastic joint location-inventory problems. *Operations Res* 2012;60(2): 366–81.
  - [48] Anstreicher KM. On convex relaxations for quadratically constrained quadratic programming. *Math Program* 2012;136(2):233–51.
  - [49] Burer S, Letchford AN. On nonconvex quadratic programming with box constraints. *SIAM J Optim* 2009;20(2):1073–89.
  - [50] Schiro DA, Zheng T, Zhao F, Litvinov E. Convex hull pricing in electricity markets: formulation, analysis, and implementation challenges. *IEEE Trans Power Syst* 2015;31(5):4068–75.
  - [51] Gribik PR, Hogan WW, Pope SL. Market-clearing electricity prices and energy uplift. 2007 [cited 5/15/2017]. URL, [www.hks.harvard.edu/fs/whogan/Gribik\\_Hogan\\_Pope\\_Price\\_Uplift\\_123107.pdf](http://www.hks.harvard.edu/fs/whogan/Gribik_Hogan_Pope_Price_Uplift_123107.pdf).
  - [52] Decker GL, Brooks AD. Valve point loading of turbines, transactions of the american institute of electrical engineers. Part III *Power Apparatus Syst* 1958;77(3):481–4.
  - [53] Modiri-Delshad M, Kaboli SHA, Taslimi-Renani E, Rahim NA. Backtracking search algorithm for solving economic dispatch problems with valve-point effects and multiple fuel options. *Energy* 2016;116:637–49.
  - [54] R. Madani, J. Lavaei, R. Baldick, Constraint screening for security analysis of power networks, *IEEE Trans Power Syst* <http://dx.doi.org/10.1109/TPWRS.2016.2611589>.
  - [55] Papadimitriou CH, Steiglitz K. *Combinatorial optimization: algorithms and complexity*. Courier Corporation; 1982.
  - [56] ApS MOSEK. The MOSEK optimization toolbox for MATLAB manual. Version 7.1 (Revision 28). 2015 [cited 5/15/2017]. URL, <http://docs.mosek.com/7.1/toolbox/index.html>.
  - [57] Grone R, Johnson CR, Sá EM, Wolkowicz H. Positive definite completions of partial hermitian matrices. *Linear algebra its Appl* 1984;58:109–24.