

# Normalization & uncertainty effects in multiple objective tasks using second-order textures

**S. Sabina Wolfson** Columbia University  
**Norma Graham** Dept of Psychology  
**& Oleg Slinin** New York, New York  
 10027 USA

## ABSTRACT

A contrast-gain control (normalization) has been demonstrated by having observers subjectively rate the perceived texture segregation of element-arrangement textures from constant-difference series of such textures (Graham & Sutter, 2000).

Here the perception of these textures is investigated using several objective tasks: **Region Segregation**, **Texture Identification**, **Uncertain Detection**, **Certain Vertical Detection**, & **Certain Horizontal Detection**

Each texture was composed of two types of elements arranged in stripes. The two types were Gabor patches, identical in spatial characteristics, but differing in contrast. We find...

- Figure 1 The "signature" of normalization is seen in all the tasks.
- Figure 2 Observers do much less well on the Region Segregation task than on the other tasks.
- Not Shown The relationship between identification and detection can be explained by the existence of second-order channels that are independent of one another.

Figure 3 The small amount by which observers do better when certain than uncertain can be explained by assuming that on each trial observers can ignore any channels that they know will not give useful information (sometimes referred to as "excluding distracters").

## METHODS

These are two pieces of stimuli used in the experiments

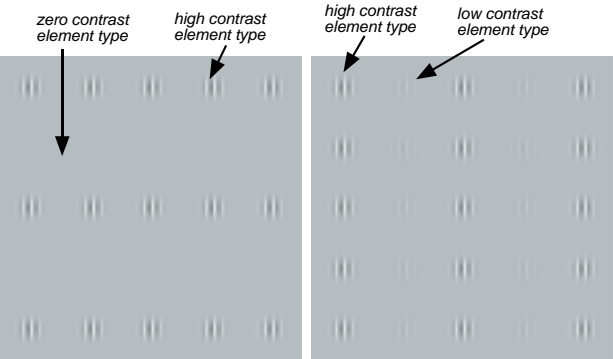

**HORIZONTALLY STRIPED** piece of stimuli  
**VERTICALLY STRIPED** piece of stimuli

- There were 5 tasks (shown at right with sketches of the patterns used)
- On each trial one pattern was shown (task question shown at right)
- Each pattern was composed of two element types arranged in stripes
- The contrast levels of the two element types varied (*constant-difference-series*)
- All elements were vertical Gabor patches
- The patterns were 15 x 15 elements (each element was about 1°)
- Stimuli were shown for 100 msec

## Region Segregation

"Is the embedded rectangle vertically or horizontally elongated?"

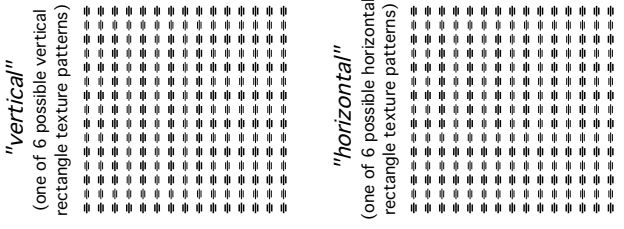

## Texture Identification

"Are the elements arranged in vertical or horizontal stripes?"

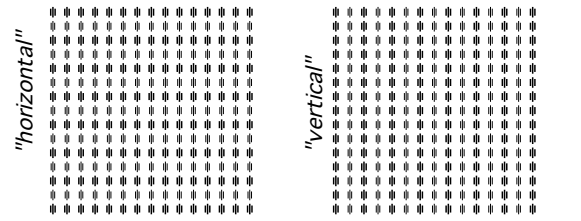

## Texture Detection

"Are the elements arranged in stripes?"

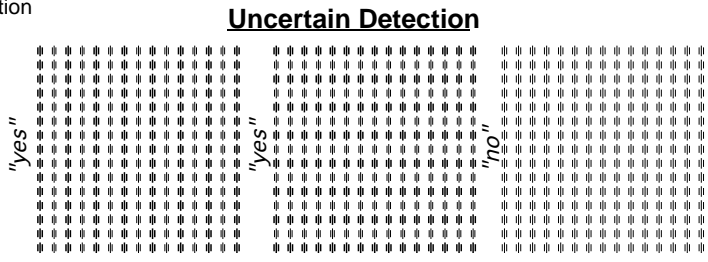

## Uncertain Detection

"Are the elements arranged in stripes?"

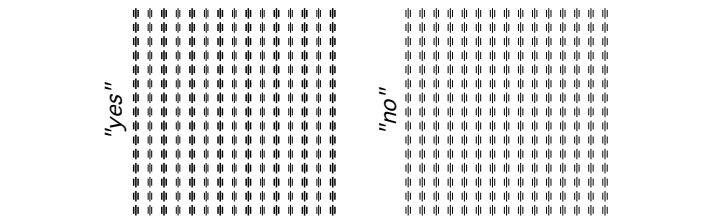

## Certain Vertical Detection

"Are the elements arranged in stripes?"

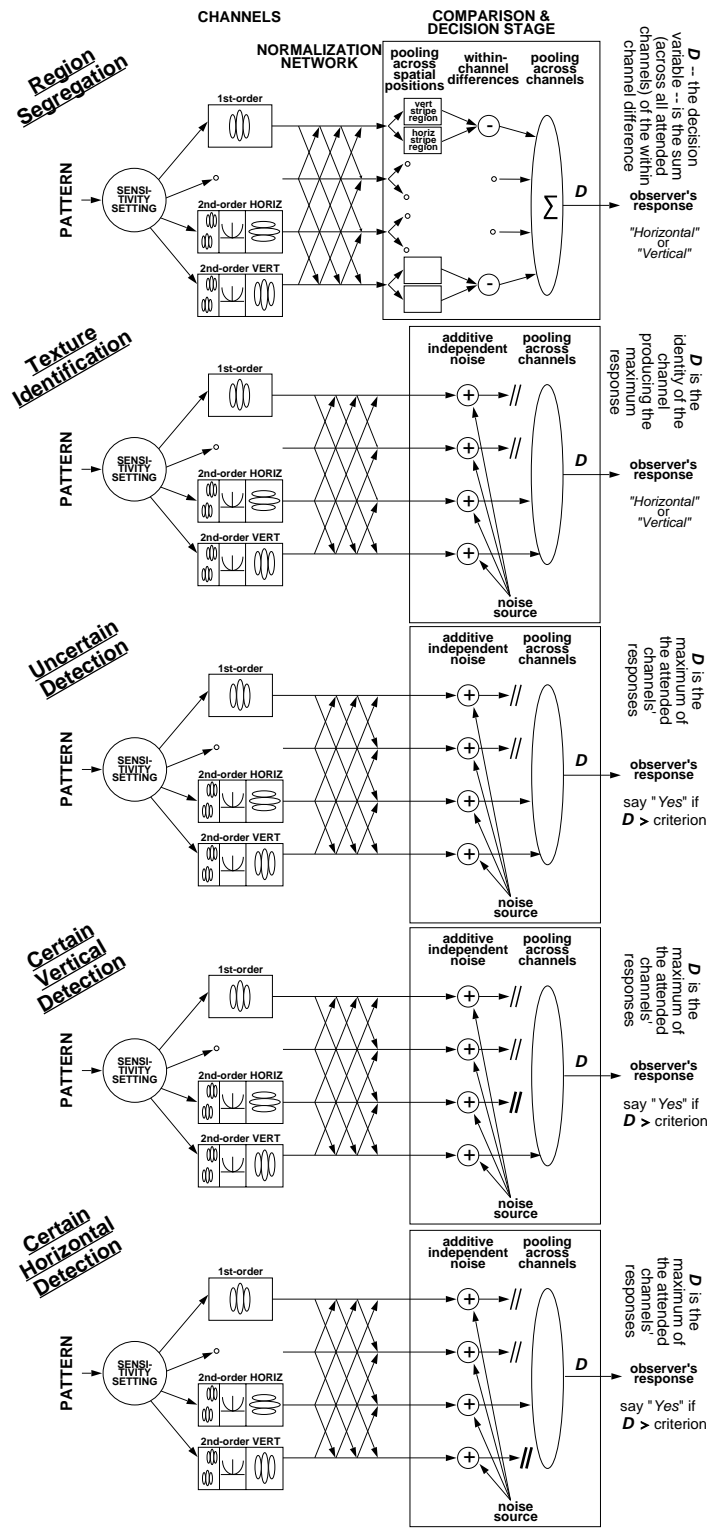
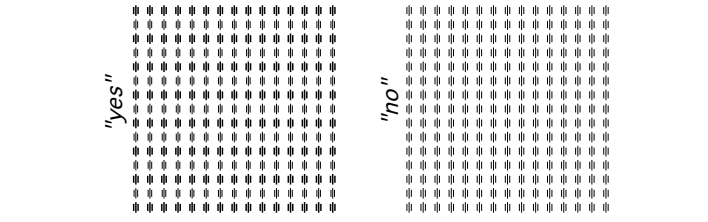

## NONLINEARITY PREDICTIONS

Predicted performance depends on the nature of the nonlinearities involved in the underlying processes. For example, a compressive nonlinearity such as normalization causes (i) performance to drop as contrast-ratio-angle increases and (ii) all the constant-difference-series to converge as shown at right...

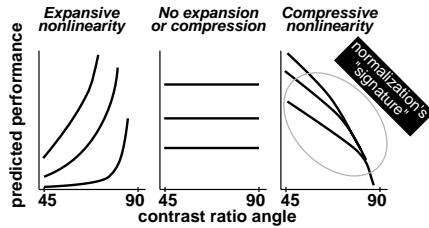

## FULL MODEL PREDICTIONS

Our results (plotted in Fig 1) look like the predictions at right from Graham & Sutter (2000): performance increases and then decreases as contrast-ratio-angle increases. Such performance necessitates a compressive nonlinearity and an expansive nonlinearity. These predictions are from a complete model with (i) a compressive intensive nonlinearity (the normalization network) and (ii) an expansive intermediate nonlinearity (between the two stages of filtering in the 2nd-order channels).

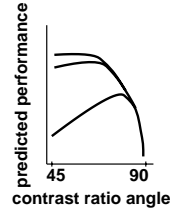
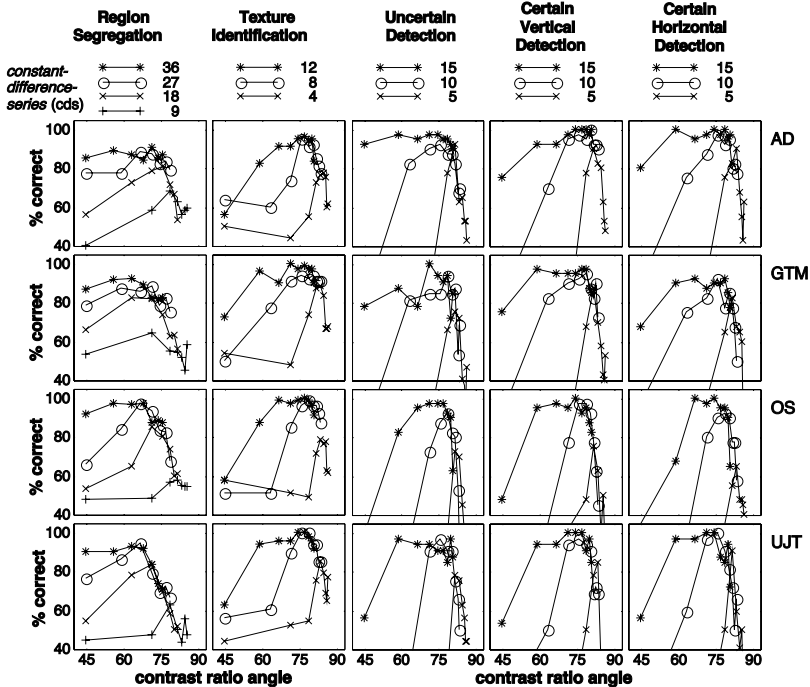

Fig 1. All the tasks show the "signature" of normalization



## ELEMENT CONTRASTS

The diagram at right shows the contrast levels used in the Region Segregation experiment plotted in the left column of Figure 1. Each point represents the contrast levels used in a pattern.

Each of the solid diagonal lines represents a constant-difference-series. All stimuli along such a line have the same difference between the contrasts of the two element types.

The dashed lines show three different contrast-ratio-angles. At a given angle the ratio of the contrasts is constant. Stimuli at 45 degrees have only one element type (the other type has zero contrast). Stimuli at 90 degrees have equal contrasts in both element types.

It is arbitrary which element type we call 1 and 2.

Details in Graham & Sutter (2000).

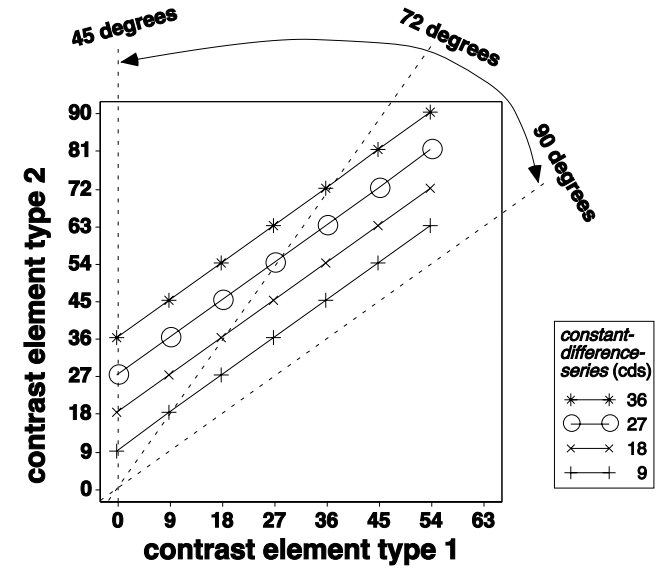
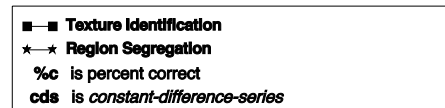

Fig 2. Region Segregation is the hardest task



### Region Segregation vs Texture Identification

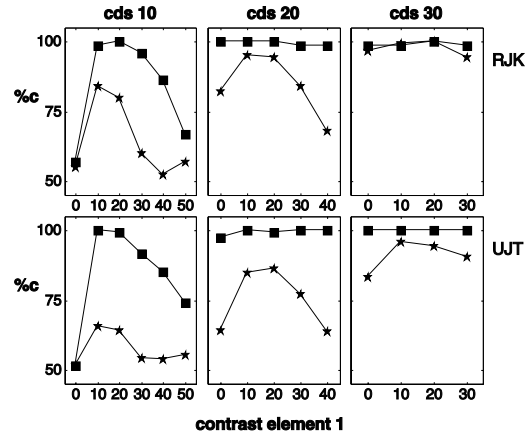
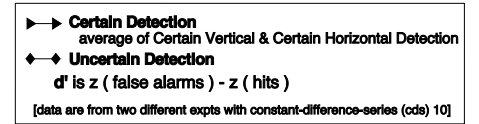
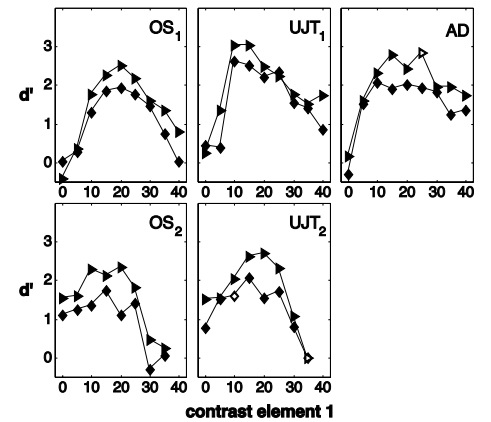

Fig 3. Second-order channels are probabilistically independent



### Certain vs Uncertain Texture Detection



## SUMMARY

Fig 1. All the tasks show the "signature" of normalization.  
 Fig 2. Region Segregation is the hardest task.  
 Fig 3. Second-order channels are probabilistically independent.

Supported by NIH grant EY08459

S. Sabina Wolfson [sabina@psych.columbia.edu](mailto:sabina@psych.columbia.edu)  
 Norma Graham [nvg1@columbia.edu](mailto:nvg1@columbia.edu)